



Bonfiglioli

Riduttori

AS series

Riduttori coassiali

Helical gear units

Stirnradgetrieben

Réducteurs coaxiaux

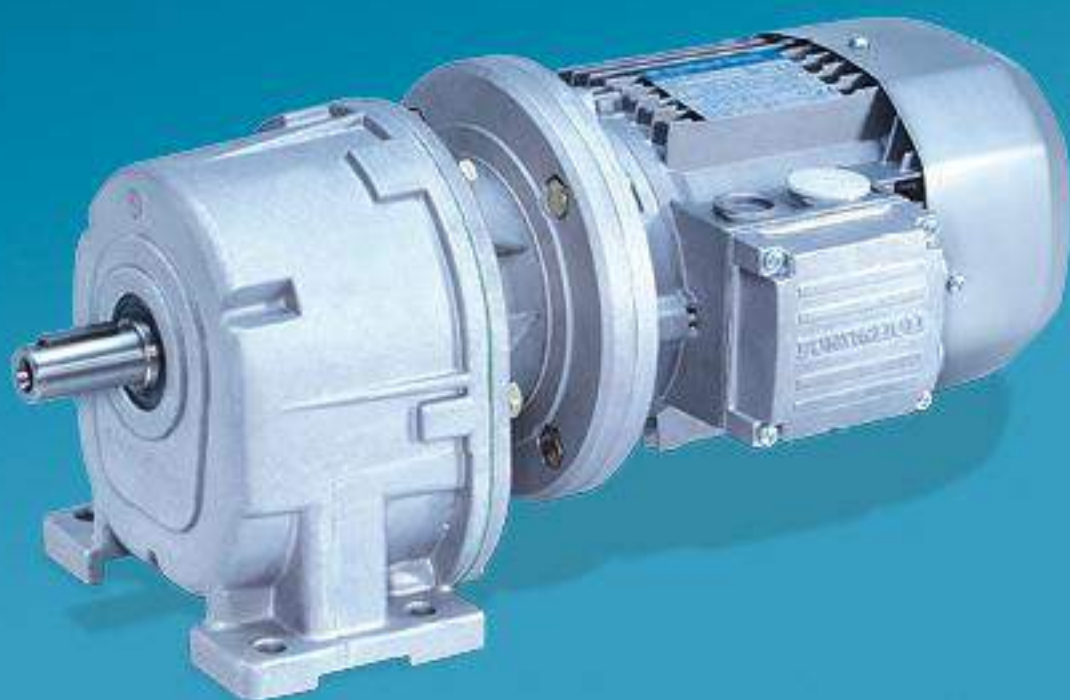

Bonfiglioli

power, control and green solutions



**INFORMAZIONI GENERALI
GENERAL INFORMATION
ALLGEMEINE INFORMATIONEN
INFORMATIONS GENERALES**

Paragrafo Heading Abschnitt Paragraphe	Descrizione	Description	Beschreibung	Description	Pagina Page Seite Page
1	Simboli e unità di misura	<i>Symbols and units of measurement</i>	Symbole und Maßeinheiten	<i>Symboles et unités de mesure</i>	2
2	Coppia	<i>Torque</i>	Abtriebsmoment	<i>Couple</i>	4
3	Potenza	<i>Power</i>	Leistung	<i>Puissance</i>	4
4	Potenza termica	<i>Thermal capacity</i>	Termische Grenzleistung	<i>Puissance thermique</i>	5
5	Rendimento	<i>Efficiency</i>	Wirkungsgrad	<i>Rendement</i>	6
6	Rapporto di riduzione	<i>Gear ratio</i>	Getriebeübersetzung	<i>Rapport de réduction</i>	6
7	Velocità angolare	<i>Angular velocity</i>	Drehzahl	<i>Vitesse angulaire</i>	7
8	Fattore di servizio	<i>Service factor</i>	Betriebsfaktor	<i>Facteur de service</i>	7
9	Manutenzione	<i>Maintenance</i>	Wartung	<i>Entretien</i>	9
10	Selezione	<i>Selection</i>	Antriebsauswahl	<i>Sélection</i>	10
11	Verifiche	<i>Verification</i>	Prüfungen	<i>Vérifications</i>	13
12	Installazione	<i>Installation</i>	Installation	<i>Installation</i>	15
13	Stoccaggio	<i>Storage</i>	Lagerung	<i>Stockage</i>	16
14	Condizioni di fornitura	<i>Conditions of supply</i>	Lieferbedingungen	<i>Conditions de livraison</i>	16
15	Specifiche della vernice	<i>Paint specifications</i>	Angaben zu den Antrichstoffe	<i>Spécifications de la peinture</i>	16

**RIDUTTORI COASSIALI SERIE AS
HELICAL GEAR UNITS SERIES AS
STIRNRADGETRIEBE SERIE AS
MOTOREDUCTEURS COAXIAUX SERIE AS**

16	Forme costruttive	<i>Versions</i>	Bauformen	<i>Formes de construction</i>	17
17	Designazione	<i>Designation</i>	Bezeichnung	<i>Désignation</i>	18
18	Lubrificazione	<i>Lubrication</i>	Schmierung	<i>Lubrification</i>	21
19	Posizioni di montaggio e orientamento morsetti	<i>Mounting position and terminal box angular position</i>	Einbaulagen und lage des klemmenkastens	<i>Positions de montage et orientation boîte a borne</i>	23
20	Carichi radiali	<i>Overhung loads</i>	Radialkräfte	<i>Charges radiales</i>	24
21	Carichi assiali	<i>Thrust loads</i>	Axialkräfte	<i>Charges axiales</i>	25
22	Dati tecnici motoriduttori	<i>Gearmotor selection charts</i>	Getriebemotorenauswahltabellen	<i>Données techniques motoréducteurs</i>	26
23	Tabelle dati tecnici riduttori	<i>Speed reducer rating charts</i>	Getriebe auswahltabellen	<i>Données techniques reducteurs</i>	54
24	Predisposizioni possibili	<i>Motor availability</i>	Anbaumöglichkeiten	<i>Prédispositions possibles</i>	69
25	Dimensioni	<i>Dimensions</i>	Abmessungen	<i>Dimensions</i>	70

**MOTORI ELETTRICI
ELECTRIC MOTORS
ELEKTROMOTOREN
MOTEURS ELECTRIQUES**

M1	Programma di produzione	Production Planning	Produktionsprogramm	Programme de production	91
M2	Normative	Reference standards	Normen	Normes	91
M3	Tolleranze	Tolerances	Toleranzen	Tolerances	93
M4	Senso di rotazione	Direction of rotation	Drehrichtung	Sens de rotation	94
M5	Cuscinetti	Bearings	Lager	Roulements	95
M6	Operatività standard	Standard operation	Standardversorgung	Conditions operatives	95
M7	Funzionamento a 60 Hz	60 Hz operation	Betrieb bei a 60 Hz	Fonctionnement a 60 Hz	97
M8	Alimentazione da inverter	Inverter control	Frequenzumrichterbetrieb	Alimentation par variateur	101
M9	Tipo di servizio	Type of duty	Betriebsarten	Type de service	103
M10	Morsetti motore	Terminal box	Motorklemmenkasten	Bornier moteur	104
M11	Forme costruttive	Design version	Bauformen	Formes de construction	106
M12	Ventilazione	Ventilation	Kühlung	Ventilation	107
M13	Designazione motore	Motor designation	Motorbezeichnung	Designation moteur	110
M14	Varianti e opzioni	Variants and options	Optionen	Variantes et options	111
M15	Grado di protezione	Degree of protection	Schutzart	Degré de protection	112
M16	Classe di isolamento	Insulation class	Isolationsklasse	Classes d'isolation	114
M17	Protezioni termiche	Thermal protective devices	Termische Wicklungsschutzeinricht	Protections thermiques	115
M18	Dispositivi di retroazione	Feedback units	Encoder / Inkrementalgeber	Dispositifs de retroaction	116
M19	Riscaldatori anticondensa	Anti-condensation heaters	Wicklungsheizung	Rechauffeurs anticondensation	118
M20	Tropicalizzazione	Tropicalization	Tropenschutz	Tropicalisation	118
M21	Esecuzioni albero motore	Rotor shaft configurations	Option der rotorwelle	Executions arbre rotor	118
M22	Equilibratura rotore	Rotor balancing	Rotorauswuchtung	Equilibrage du rotor	119
M23	Protezioni meccaniche esterne	External mechanical protections	Mechanische Schutzvorrichtung	Protections mecaniques exterieures	120
M24	Motori asincroni autofrenanti	Asynchronous brake motors	Drehstrombremsmotoren	Moteurs frein asynchrones	121
M25	Motori autofrenanti in C.C., tipo BN_FD	DC brake motors type BN_FD	Wechselstrom-Bremsmotoren mit G.S.-Bremsse Typ BN_FD	Moteurs frein en C.C., type BN_FD	127
M26	Motori autofrenanti in C.A., tipo BN_FA	AC brake motors type BN_FA	Wechselstrom-Bremsmotoren mit W.S.-Bremsse Typ BN_FA	Moteurs frein en C.A., type BN_FA	133
M27	Motori autofrenanti in C.A., tipo BN_BA	AC brake motors type BN_BA	Wechselstrom-Bremsmotoren mit W.S.-Bremsse Typ BN_BA	Moteurs frein en C.A., type BN_BA	137
M28	Dati tecnici motori	Motor rating charts	Motorenauswahl Tabellen	Données techniques des moteurs	141
M29	Dimensioni	Dimensions	Abmessungen	Dimensions	153

Revisióni
L'indice di revisione del catalogo è riportato a pag. 162.
Al sito www.bonfiglioli.com sono disponibili i cataloghi con le revisioni aggiornate.

Revisions
Refer to page 162 for the catalogue revision index.
Visit www.bonfiglioli.com to search for catalogues with up-to-date revisions.

Änderungen
Das Revisionsverzeichnis des Katalogs wird auf Seite 162 wiedergegeben. Auf unserer Website www.bonfiglioli.com werden die Kataloge in ihrer letzten, überarbeiteten Version angeboten.

Révisions
Le sommaire de révision du catalogue est indiqué à la page 162.
Sur le site www.bonfiglioli.com des catalogues avec les dernières révisions sont disponibles.

**1 - SIMBOLI E UNITÀ
DI MISURA**
**1 - SYMBOLS AND UNITS
OF MEASUREMENT**
**1 - SYMBOLE UND
MAßEINHEITEN**
**1 - SYMBOLES ET
UNITES DE MESURE**

Simb. Symb.	U.m. Meße- inh.	Descrizione	Description	Beschreibung	Description
$A_{N 1, 2}$ [N]		Carico assiale nominale	<i>Permissible axial force</i>	Nenn-Axialbelastung	<i>Charge axiale nominale</i>
f_s	–	Fattore di servizio	<i>Service factor</i>	Betriebsfaktor	<i>Facteur de service</i>
f_T	–	Fattore termico	<i>Thermal factor</i>	Temperaturfaktor	<i>Facteur thermique</i>
f_{TP}	–	Fattore di temperatura	<i>Temperature factor</i>	Wärmefaktor	<i>Facteur de température</i>
i	–	Rapporto di trasmissione	<i>Gear ratio</i>	Übersetzung	<i>Rapport de réduction</i>
I	–	Rapporto di intermittenza	<i>Cyclic duration factor</i>	Relative Einschaltdauer	<i>Rapport d'intermittence</i>
J_C	[Kgm ²]	Momento di inerzia carico	<i>Mass moment of inertia to be driven</i>	Massenträgheitsmoment der externen Massen	<i>Moment d'inertie de la charge</i>
J_M	[Kgm ²]	Momento di inerzia motore	<i>Motor mass moment of inertia</i>	Motorträgheitsmoment	<i>Moment d'inertie du moteur</i>
J_R	[Kgm ²]	Momento di inerzia riduttore	<i>Mass moment of inertia for the gear unit</i>	Getriebeträgheitsmoment	<i>Moment d'inertie du réducteur</i>
K	–	Fattore di accelerazione delle masse	<i>Mass acceleration factor</i>	Massenbeschleunigungsfaktor	<i>Facteur d'accélération des masses</i>
K_r	–	Costante di trasmissione	<i>Transmission element factor</i>	Belastungsfaktor der Radiallast	<i>Constante de transmission</i>
$M_{1, 2}$ [Nm]		Coppia	<i>Torque</i>	Drehmoment	<i>Couple</i>
$M_c 1, 2$ [Nm]		Coppia di calcolo	<i>Calculated torque</i>	Berechnetes Drehmoment	<i>Couple de calcul</i>
$M_n 1, 2$ [Nm]		Coppia nominale	<i>Rated torque</i>	Nennmoment	<i>Couple nominal</i>
$M_r 1, 2$ [Nm]		Coppia richiesta	<i>Torque demand</i>	Benötigtes Drehmoment	<i>Couple nécessaire</i>
$n_{1, 2}$ [min ⁻¹]		Velocità angolare	<i>Rotational speed</i>	Abtriebsdrehzahl	<i>Vitesse</i>
$P_{1, 2}$ [kW]		Potenza	<i>Power</i>	Leistung	<i>Puissance</i>
$P_N 1, 2$ [kW]		Potenza nominale	<i>Rated power</i>	Nennleistung	<i>Puissance nominale</i>
$P_R 1, 2$ [kW]		Potenza richiesta	<i>Power demand</i>	Benötigte Leistung	<i>Puissance nécessaire</i>
$R_C 1, 2$ [N]		Carico radiale di calcolo	<i>Calculated radial force</i>	Berechnete Axialbelastung	<i>Charge radiale de calcul</i>
$R_N 1, 2$ [N]		Carico radiale nominale	<i>Permissible overhung load</i>	Zulässige Radialbelastung	<i>Charge radiale nominale</i>
S	–	Fattore di sicurezza	<i>Safety factor</i>	Sicherheitsfaktor	<i>Facteur de sécurité</i>
t_a	[°C]	Temperatura ambiente	<i>Ambient temperature</i>	Umgebungstemperatur	<i>Température ambiante</i>
t_f	[min]	Tempo di funzionamento a carico costante	<i>Work time at constant load</i>	Betriebszeit während nennbetrieb	<i>Temps de fonctionnement à charge constante</i>
t_r	[min]	Tempo di riposo	<i>Rest time</i>	Stillstandszeit	<i>Temps de repos</i>
η_d	–	Rendimento dinamico	<i>Dynamic efficiency</i>	Dynamischer Wirkungsgrad	<i>Rendement dynamique</i>
η_s	–	Rendimento statico	<i>Static efficiency</i>	Statischer Wirkungsgrad	<i>Rendement statique</i>

1 valore riferito all'albero veloce

1 value applies to i/p shaft

1 Werte beziehen sich auf die Antriebswelle

1 valeurs pour l'arbre rapide

2 valore riferito all'albero lento

2 value applies to o/p shaft

2 Werte beziehen sich auf die Abtriebswelle

2 valeurs pour l'arbre lent



Questo simbolo riporta i riferimenti angolari per l'indicazione della direzione del carico radiale (l'albero è visto di fronte).



This symbol refers to the angle the overhung load applies (viewing from drive end).



Dieses Symbol gibt die Winkelbezugswerte für die Angabe der Richtung der Radialkräfte an (Stirnsicht der Welle).



Ce symbole présente les références angulaires pour l'indication de la direction de la charge radiale (l'arbre est vu de face).



Simbolo riferito al peso dei riduttori e dei motoriduttori. I valori riportati nelle tabelle dei motoriduttori sono comprensivi sia del peso del motore a 4 poli sia del peso del lubrificante contenuto, qualora previsto da BONFIGLIOLI RIDUTTORI.



Symbol refers to weight of gearmotors and speed reducers. Figure for gearmotors incorporates the weight of the 4-pole motor and for life lubricated units, where applicable, the weight of the oil.



Symbol für das Gewicht der Getriebe und der Getriebemotoren. Die in der Getriebemotoren-Tabelle genannten Werte schließen das Gewicht des vierpoligen Motors und die eingefüllte Schmierstoffmenge ein, sofern von BONFIGLIOLI RIDUTTORI vorgesehen.



Symbole se référant aux poids des réducteurs et des motoréducteurs. Les valeurs indiquées dans les tableaux des motoréducteurs comprennent tant le poids du moteur à 4 pôles que le poids du lubrifiant contenu, lorsque prévu par BONFIGLIOLI RIDUTTORI.



Il simbolo identifica la pagina alla quale può essere reperita l'informazione.



The symbol shows the page the information can be sorted from.



Das Symbol Kennzeichnet die Seite, auf die die Information gefunden werden kann.



Le symbole identifie la page à laquelle l'on peut trouver l'information.



Motoriduttore con motore IEC.



Gearmotor with IEC motor.



Getriebemotor mit IEC-Motor.



Motoréducteur avec moteur normalisé CEI.



Riduttore predisposto per accoppiamento a motore tipo IEC.



Gear unit with IEC motor interface.



Getriebe vorbereitet für IEC-motor.



Réducteur prédisposé pour liaison a moteur IEC



Riduttore dotato di albero veloce cilindrico.



Speed reducer with solid input shaft.



Getriebe mit cylindrischer Antriebswelle.



Réducteur avec arbre rapide Cylindrique.

**INFORMAZIONI GENERALI**

I paragrafi che seguono riportano una serie di informazioni sugli elementi indispensabili per la scelta e il corretto utilizzo dei motoriduttori.

GENERAL INFORMATION

The following headings contain information on essential elements for selection and correct use of gearmotors.

ALLGEMEINEINFORMATIONEN

Die folgenden Abschnitte enthalten eine Reihe von Informationen über die Aspekte, die in Hinblick auf die Wahl und den sachgemäßen Betrieb von Getriebemotoren unbedingt zu berücksichtigen sind.

INFORMATIONS GENERALES

Les paragraphes qui suivent présentent une série d'informations sur les éléments indispensables pour le choix et l'utilisation correcte des motoréducteurs.

2 - COPPIA**Coppia nominale**
M_{n2} [Nm]

È la coppia trasmissibile in uscita con carico continuo uniforme, riferita alla velocità in ingresso n₁ e a quella corrispondente in uscita n₂.

È calcolata in base ad un fattore di servizio f_s = 1.

Coppia richiesta
M_{r2} [Nm]

Rappresenta la coppia richiesta dall'applicazione e dovrà sempre essere uguale o inferiore alla coppia in uscita nominale M_{n2} del riduttore scelto.

Coppia di calcolo
M_{c2} [Nm]

È il valore di coppia da utilizzare per la selezione del riduttore considerando la coppia richiesta M_{r2} e il fattore di servizio f_s ed è dato dalla formula:

2 - TORQUE**Rated torque**
M_{n2} [Nm]

Torque transmissible through output shaft, under uniform loading and based on service factor f_s=1. Rating refers to specific n₁ input speeds.

Required torque
M_{r2} [Nm]

Torque corresponding to application requirements. It must always be equal to or less than rated output torque M_{n2} for the gearbox under study.

Calculated torque
M_{c2} [Nm]

Torque value to be used when selecting the gearbox, considering required torque M_{r2} and service factor f_s, and is obtained through the equation:

2 - ABTRIEBSMOMENT**Nenn-Drehmoment**
M_{n2} [Nm]

Dies ist das an der Abtriebswelle übertragbare Drehmoment bei gleichförmiger Dauerbelastung bezogen auf die Antriebsdrehzahl n₁ und die entsprechende Abtriebsdrehzahl n₂.

Das Drehmoment wird auf Grundlage eines Betriebsfaktor f_s = 1 berechnet.

Verlangtes Drehmoment
M_{r2} [Nm]

Dies ist das von der Anwendung verlangte Drehmoment, das stets kleiner oder gleich dem Nenn-Abtriebsmoment M_{n2} des gewählten Getriebes sein muß.

Soll-Drehmoment
M_{c2} [Nm]

Dies ist das bei der Wahl des Getriebes zugrundezulegende Drehmoment, wobei das übertragene Drehmoment M_{r2} und der Betriebsfaktor f_s zu berücksichtigen sind; das Soll-Drehmoment wird mit folgender Gleichung berechnet:

2 - COUPLE**Couple nominal**
M_{n2} [Nm]

C'est le couple transmissible en sortie avec une charge continue uniforme se référant à la vitesse en entrée n₁ et à celle correspondante en sortie n₂.

Il est calculé sur la base d'un facteur de service f_s = 1.

Couple requis
M_{r2} [Nm]

Il représente le couple requis par l'application et devra toujours être inférieur ou égal au couple en sortie nominal M_{n2} du réducteur choisi.

Couple de calcul
M_{c2} [Nm]

C'est la valeur de couple à utiliser pour la sélection du réducteur en considérant le couple requis M_{r2} et le facteur de service f_s et s'obtient avec la formule :

$$M_{c2} = M_{r2} \cdot f_s \leq M_{n2} \quad (1)$$

3 - POTENZA**Potenza nominale in entrata** P_{n1} [kW]

Nelle tabelle di selezione dei riduttori è la potenza applicabile in entrata riferita alla velocità n₁, considerando un fattore di servizio f_s = 1.

3 - POWER**Input rated power** P_{n1} [kW]

In the gearbox selection charts this is the power applicable to input shaft, based on input speed n₁ and corresponding to service factor f_s = 1.

3 - LEISTUNG**Leistung Antriebswelle** P_{n1} [kW]

In den Tabellen für die Wahl der Getriebe ist die an der Antriebswelle übertragbare Leistung auf die Drehzahl n₁ bezogen und es wurde ein Betriebsfaktor f_s = 1 angenommen.

3 - PUISSANCE**Puissance en entrée** P_{n1} [kW]

Dans les tableaux de sélection des réducteurs, c'est la puissance applicable en entrée se rapportant à la vitesse n₁ et en considérant un facteur de service f_s = 1.



4 - POTENZA TERMICA
 P_t [kW]

P_t è il valore che indica il limite termico del riduttore e rappresenta la potenza trasmissibile in servizio continuo, e alla temperatura ambiente $t_a = 20\text{ °C}$, senza che si producano danneggiamenti negli organi del riduttore o degradamenti del lubrificante. Vedi tab. (A1).

Nel caso di servizio intermittente, o di temperatura ambiente inferiore a 20 °C , il valore di P_t deve essere corretto per mezzo del fattore f_t , espresso dalla tabella (A2), ossia $P_t' = P_t \times f_t$.

Infine, per riduttori con più di due riduzioni e/o con rapporto $i > 45$ la verifica della potenza termica non è necessaria in quanto quest'ultima è certamente superiore alla potenza meccanica trasmissibile.

4 - THERMAL CAPACITY
 P_t [kW]

P_t is the power that can be transmitted through the gear unit, under a continuous duty and an ambient temperature of 20 °C , without resulting into damage of the inner parts or degradation of the lubricant properties. Refer to chart (A1) for specific kW ratings.

In case of intermittent duty, or an operating ambient temperature other than the rated 20 °C , the P_t value should be adjusted through the factor f_t , obtained from chart (A2), as per the following equation: $P_t' = P_t \times f_t$.

Gear units featuring more than 2 reductions and/or a gear ratio larger than $i > 45$ do not normally require the thermal limit to be checked as in these cases the thermal rating usually exceeds the mechanical rating.

4 - THERMISCHE GRENZLEISTUNG
 P_t [kW]

P_t steht für den Wert der Wärmegrenzleistung des Getriebes und gibt die im Dauerbetrieb und bei einer Umgebungstemperatur $t_a = 20\text{ °C}$ übertragbare Leistung an, ohne daß sich daraus Schäden an den Getriebeorganen oder ein Verfall des Schmiermittels ergeben. Siehe Tab. (A1). Bei einem Aussetzbetrieb oder einer unter 20 °C liegenden Umgebungstemperatur muß der Wert P_t über den Faktor f_t korrigiert werden, der in der Tabelle (A2) aufgeführt wird bzw. $P_t' = P_t \times f_t$.

Bei Getrieben mit mehr als zwei Untersetzungsstufen und/oder einem Verhältnis von $i > 45$ ist die Kontrolle der thermischen Leistung nicht erforderlich, da sie sicher oben der mechanisch übertragbaren Leistung liegt.

4 - PUISSANCE THERMIQUE
 P_t [kW]

P_t est la valeur qui indique la limite thermique du réducteur et représente la puissance transmissible en service continu, et à une température ambiante $t_a = 20\text{ °C}$, sans apparition de dommages au niveau des organes du réducteur ou de dégradations du lubrifiant. Voir tab. (A1). En cas de service intermittent ou de température ambiante inférieure à 20 °C , la valeur de P_t doit être corrigée au moyen du facteur f_t , exprimé dans le tableau (A2), à savoir: $P_t' = P_t \times f_t$.

Enfin, pour les réducteurs ayant plus de deux réductions et/ou un rapport $i > 45$, la vérification de la puissance thermique n'est pas nécessaire car elle est certainement supérieure à la puissance mécanique transmissible.

(A1)

	P_t [kW] 20 °C	
	$n_1 = 1400\text{ min}^{-1}$	$n_1 = 2800\text{ min}^{-1}$
	AS 16	3.3
AS 20	4.7	3.3
AS 25	6.0	4.2
AS 30	7.8	5.5
AS 35	10.8	7.5
AS 45	13.9	9.8
AS 55	20.8	15.6
AS 60	31	23
AS 80	43	31
AS 90	59	42

(A2)

t_a [°C]	Servizio continuo <i>Continuous duty</i> Dauerbetrieb <i>Service continu</i>	f_t			
		Servizio intermittente / <i>Intermittent duty</i> / Aussetzbetrieb / <i>Service intermittent</i>			
		Grado di intermittenza / <i>Degree of intermittence</i> / Relative Einschaltdauer / <i>Degrè d'intermittence</i> (I)			
		80%	60%	40%	20%
40	0.80	1.1	1.3	1.5	1.6
30	0.85	1.3	1.5	1.6	1.8
20	1.0	1.5	1.6	1.8	2.0
10	1.15	1.6	1.8	2.0	2.3

Il grado di intermittenza (I)% è dato dal rapporto fra il tempo di

Where cyclic duration factor (I)% is the relationship of oper-

Wobei die Einschaltdauer (I)% von dem Verhältnis zwischen

Où le degré d'intermittence (I)% est fourni par le rapport entre le



funzionamento a carico t_f e il tempo totale ($t_f + t_r$), espresso in percentuale.

ating time under load t_f and total time ($t_f + t_r$) expressed as a percentage.

Betriebszeit unter Last t_f und der Gesamtbetriebszeit ($t_f + t_r$), ausgedrückt in Prozenten, gegeben wird.

temps de fonction en charge et le temps total ($t_f + t_r$) exprimé en pourcentage.

$$I = \frac{t_f}{t_f + t_r} \cdot 100 \quad (2)$$

La condizione da verificare è:

The condition to verify is:

Die durchzuführende Kontrolle ist:

La vérification à faire sera la suivante :

$$P_{r1} \leq P_t \times f_t \quad (3)$$

5 - RENDIMENTO « η »

5 - EFFICIENCY « η »

5 - WIRKUNGSGRAD « η »

5 - RENDEMENT « η »

È dato dal rapporto fra la potenza in uscita P_2 e quella in entrata P_1 secondo la relazione:



Obtained from the relationship of output power P_2 to input power P_1 according to the following equation:

Er ist gegeben durch das Verhältnis der Abtriebsleistung P_2 zur Antriebsleistung P_1 :

Il est donné par le rapport entre la puissance en sortie P_2 et celle en entrée P_1 :

$$\eta = \frac{P_2}{P_1} \cdot 100 \quad [\%] \quad (4)$$

(A3)

	2 x 	3 x 
η	95%	93%

6 - RAPPORTO DI RIDUZIONE « i »

6 - GEAR RATIO « i »

6 - GETRIEBEÜBERSETZUNG « i »

6 - RAPPORT DE REDUCTION « i »

Il valore del rapporto di riduzione della velocità, identificato con il simbolo $[i]$, è espresso tramite il rapporto fra le velocità all'albero veloce e lento del riduttore e riassunto nell'espressione:

The value for the gear ratio is referred to with the letter $[i]$ and calculated through the relationship of the input speed n_1 to the output speed n_2 :

Die Übersetzung des Getriebes wird mit dem Buchstaben $[i]$ bezeichnet und ist folgendermaßen definiert:

Le rapport de réduction est identifiée par la lettre $[i]$ et son calcul s'effectue à partir de la vitesse d'entrée n_1 et de la vitesse de sortie n_2 en utilisant la relation suivante :

$$i = \frac{n_1}{n_2} \quad (5)$$

Il rapporto di riduzione è solitamente un numero decimale che viene rappresentato nel catalogo con una sola cifra decimale, o nessuna nel caso di $i > 1000$. Se si è interessati a conoscere il numero in tutte le componenti decimali consultare il Servizio Tecnico di Bonfiglioli Riduttori.

The gear ratio is usually a decimal fraction which in this catalogue is truncated at one digit after the comma (no decimals for $i > 1000$). If interested in knowing the complete figure please consult Bonfiglioli's Technical Service.

In diesem Katalog wird die Übersetzung mit einer Stelle hinter dem Komma angegeben, bei Übersetzungen > 1000 ohne Dezimalstelle. Wenn genaue Angaben zur Übersetzung benötigt werden, wenden sie sich bitte an den technischen Service von Bonfiglioli Riduttori.

Dans le catalogue, le rapport de réduction a une précision d'un chiffre après la virgule (sauf pour $i > 1000$). Si une plus grande précision est nécessaire, contacter le Service Technique de Bonfiglioli.



7 - VELOCITÀ ANGOLARE

7 - ANGULAR VELOCITY

7 - DREHZAHL

7 - VITESSE ANGULAIRE

Velocità in entrata n_1 [min^{-1}]

È la velocità relativa al tipo di motorizzazione scelta; i valori di catalogo si riferiscono alle velocità dei motori elettrici comunemente usati a singola e doppia polarità.

Se il riduttore riceve il moto da una trasmissione in entrata, è sempre preferibile adottare velocità inferiori a 1400 min^{-1} al fine di garantire condizioni ottimali di funzionamento.

Velocità in entrata superiori sono ammesse considerando il naturale declassamento della coppia nominale M_{n2} del riduttore.

Velocità in uscita n_2 [min^{-1}]

È in funzione della velocità in entrata n_1 e del rapporto di riduzione i secondo la relazione:

Input speed n_1 [min^{-1}]

Speed is related to the prime mover selected. Catalogue values refer to speed of either single or double speed motors that are common in the industry.

If the gearbox is driven by an external transmission it is recommended to operate it with a speed of 1400 min^{-1} or lower in order to optimise operating conditions and lifetime.

Higher input speeds are permitted, however in this case consider that torque rating M_{n2} is affected adversely.

Please consult a Bonfiglioli representative.

Output speed n_2 [min^{-1}]

The output speed n_2 is calculated from the relationship of input speed n_1 to the gear ratio i , as per the following equation:

Drehzahl Antriebswelle n_1 [min^{-1}]

Dies ist die vom gewählten Motortyp abhängige Drehzahl. Die Katalogangaben beziehen sich auf die Drehzahl von allgemeinüblichen eintourigen Elektromotoren oder von polumschaltbaren Elektromotoren.

Um optimale Betriebsbedingungen zu gewährleisten, ist stets eine Antriebsdrehzahl unter 1400 min^{-1} zu empfehlen.

Höhere Antriebsdrehzahlen sind zulässig, wobei die zwangsläufige Herabsetzung des Nenn-Abtriebsdrehmoments M_{n2} des Getriebes zu berücksichtigen ist.

Abtriebsdrehzahl n_2 [min^{-1}]

Sie ist abhängig von der Antriebsdrehzahl n_1 und dem Übersetzungs i nach folgender Gleichung:

Vitesse d'entrée n_1 [min^{-1}]

C'est la vitesse relative au type de motorisation choisie. Les valeurs de catalogue se réfèrent aux vitesses des moteurs électriques à simple et double polarité communément utilisés.

Si le réducteur reçoit le mouvement d'une transmission en entrée, il est toujours préférable d'adopter des vitesses inférieures à 1400 min^{-1} afin de garantir des conditions optimales de fonctionnement.

Des vitesses d'entrée supérieures sont admises en considérant le déclassement naturel du couple nominal M_{n2} du réducteur.

Vitesse en sortie n_2 [min^{-1}]

Elle varie en fonction de la vitesse d'entrée n_1 et du rapport de réduction i selon l'équation :

$$n_2 = \frac{n_1}{i} \quad (6)$$

8 - FATTORE DI SERVIZIO « f_s »

Il fattore di servizio è il parametro che traduce in un valore numerico la gravosità del servizio che il riduttore è chiamato a svolgere, tenendo conto, benché con inevitabile approssimazione, del funzionamento giornaliero, della variabilità del carico e di eventuali sovraccarichi, connessi con la specifica applicazione del riduttore.

Nel grafico (A4) più sotto riportato il fattore di servizio si ricava, dopo aver selezionato la colonna relativa alle ore di funzionamento giornaliere, per intersezione fra il numero di avviamenti orari e una fra le curve K1, K2 e K3.

Le curve $K_$ sono associate alla natura del servizio (approssimativamente: uniforme, medio e pesante) tramite il fattore di

8 - SERVICE FACTOR « f_s »

This factor is the numeric value describing reducer service duty. It takes into consideration, with unavoidable approximation, daily operating conditions, load variations and overloads connected with reducer application. In diagram (A4) here below, after selecting proper "daily working hours" column, the service factor is given by intersecting the number of starts per hour and one of the K1, K2 or K3 curves.

$K_$ curves are linked with the service nature (approximately: uniform, medium and heavy) through the acceleration factor of masses K , connected to the ratio between driven masses and motor inertia values.

Regardless of the value given for the service factor, we would

8 - BETRIEBSFAKTOR « f_s »

Beim Betriebsfaktor handelt es sich um den Parameter, der die Betriebsbelastung, die das Getriebe aushalten muss, in einem Wert ausdrückt. Dabei berücksichtigt er, auch wenn nur mit einer unvermeidbaren Annäherung, den täglichen Einsatz, die unterschiedlichen Belastungen und eventuelle Überbelastungen, die mit der spezifischen Applikation des Getriebes verbunden sind.

Der nachstehenden Grafik (A4) kann, nach der Wahl der entsprechenden Spalte mit der Angabe der täglichen Betriebsstunden der Betriebsfaktor entnommen werden, indem man die Schnittstelle zwischen der stündlichen Schaltungen und einer der Kurven K1, K2 und K3 sucht. Die mit $K_$ gekennzeichneten

8 - FACTEUR DE SERVICE « f_s »

Le facteur de service est le paramètre qui traduit en une valeur numérique la difficulté du service que le réducteur est appelé à effectuer en tenant compte, avec une approximation inévitable, du fonctionnement journalier, de la variabilité de la charge et des éventuelles surcharges liées à l'application spécifique du réducteur.

Sur le graphique (A4) ci-dessous, le facteur de service peut être trouvé, après avoir sélectionné la colonne relative aux heures de fonctionnement journalier, à l'intersection entre le nombre de démarrages horaires et l'une des courbes K1, K2 et K3.

Les courbes $K_$ sont associées à la nature du service (approximativement : uniforme, moyen



accelerazione delle masse K, legato al rapporto fra le inerzie delle masse condotte e del motore.

Indipendentemente dal valore così ricavato del fattore di servizio, segnaliamo che esistono applicazioni fra le quali, a puro titolo di esempio i sollevamenti, per le quali il cedimento di un organo del riduttore potrebbe esporre il personale che opera nelle immediate vicinanze a rischio di ferimento.

Se esistono dubbi che l'applicazione possa presentare questa criticità vi invitiamo a consultare preventivamente il ns. Servizio Tecnico.

like to remind that in some applications, which for example involve lifting of parts, failure of the reducer may expose the operators to the risk of injuries.

If in doubt, please contact our Technical Service.

neten Kurven sind über den Beschleunigungsfaktor der Massen K an die Betriebsart gekoppelt (annähernd: gleichmäßige, mittlere oder starke Belastung), der wiederum an das Verhältnis zwischen Trägheitsmoment der angetriebenen Massen und dem des Motors gebunden ist. Unabhängig von dem so erhaltenen Betriebsfaktor, möchten wir Sie darauf hinweisen, dass es Applikationen gibt, unter denen beispielsweise auch die Hebefunktionen zu finden sind, bei denen das Nachgeben eines Getriebeorgans, das in dessen Nähe arbeitende Personal einer Verletzungsgefahr aussetzen könnte. Sollten daher Zweifel darüber bestehen, ob die entsprechende Applikation sich in diesem Bezug als kritisch erweist, bitten wir Sie sich zuvor mit unseren Technischen Kundendienst in Verbindung zu setzen.

et difficile) au moyen du facteur d'accélération des masses K, lié au rapport entre les inerties des masses conduites et le moteur.

Indépendamment de la valeur du facteur de service ainsi trouvée, nous signalons qu'il existe des applications parmi lesquelles, à titre d'exemple, les levages, pour lesquels la rupture d'un organe du réducteur pourrait exposer le personnel opérant à proximité immédiate à des risques de lésion.

En cas de doute concernant les risques éventuels de l'application, nous vous conseillons de contacter préalablement notre Service Technique.

(A4)

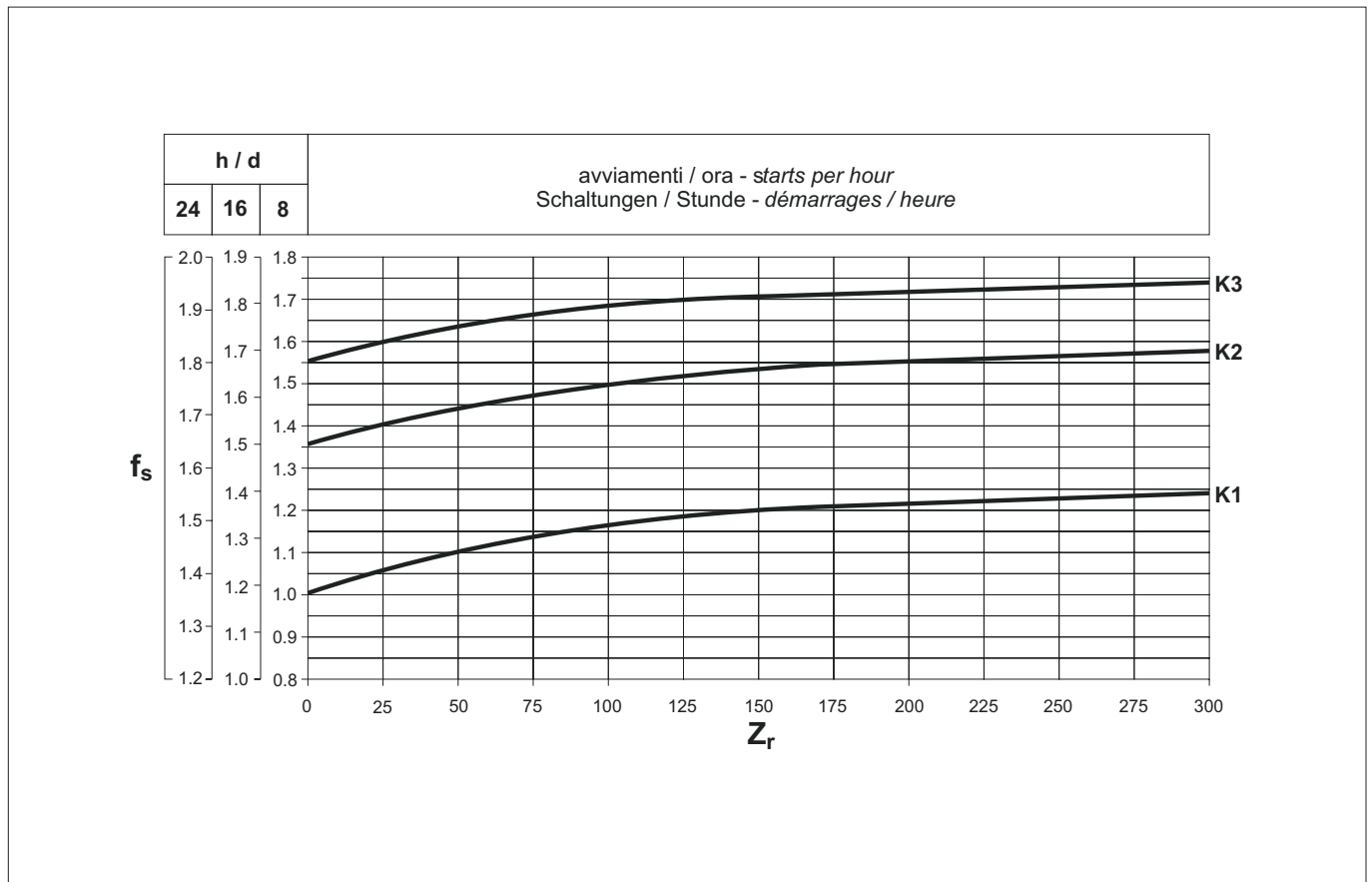

Fattore di accelerazione delle masse, K

Acceleration factor of masses, K

Beschleunigungsfaktor der Massen, K

Facteur d'accélération des masses, K

Il parametro serve a selezionare la curva relativa al particolare

This parameter serves for selecting the right curve for the

Dieser Parameter dient der Wahl der Kurve, die sich auf die

Le paramètre sert à sélectionner la courbe relative au type



tipo di carico. Il valore è dato dal rapporto:

type of load. The value is given by the following ratio:

jeweilige Belastungsart bezieht. Der Wert ergibt sich aus folgender Formel:

de charge particulier. La valeur est obtenue par l'équation :

$$K = \frac{J_c}{J_m} \quad (7)$$

dove:

J_c momento d'inerzia delle masse comandate, riferito all'albero del motore

J_m momento d'inerzia del motore

$K \leq 0.25$ – curva **K1**
carico uniforme

$0.25 < K \leq 3$ – curva **K2**
carico con urti moderati

$3 < K \leq 10$ – curva **K3**
carico con forti urti

Per valori di $K > 10$ invitiamo a consultare il nostro Servizio Tecnico.

where:

J_c *moment of inertia of driven masses referred to motor driving shaft*

J_m *moment of inertia of motor*

$K \leq 0.25$ – curve **K1**
uniform load

$0.25 < K \leq 3$ – curve **K2**
moderate shock load

$3 < K \leq 10$ – curve **K3**
heavy shock load

For K values > 10, please contact our Technical Service.

wobei:

J_c Trägheitsmoment der angetriebenen Massen, bezogen auf die Motorwelle

J_m Trägheitsmoment des Motors

$K \leq 0.25$ – Kurve **K1**
Gleichmäßige Belastung

$0.25 < K \leq 3$ – Kurve **K2**
Belastung mit mäßigen Stößen

$3 < K \leq 10$ – Kurve **K3**
Belastung mit starken Stößen

Bei Werten $K > 10$ bitten wir Sie, sich mit unserem Technischen Kundendienst in Verbindung zu setzen.

où:

J_c *moment d'inertie des masses commandées se référant à l'arbre du moteur.*

J_m *moment d'inertie du moteur*

$K \leq 0.25$ – courbe **K1**
charge uniforme

$0.25 < K \leq 3$ – courbe **K2**
charge avec chocs modérés

$3 < K \leq 10$ – courbe **K3**
charge avec chocs importants

Pour des valeurs de K > 10, nous vous conseillons de contacter notre Service Technique.

9 - MANUTENZIONE

I riduttori forniti con lubrificazione permanente non necessitano di sostituzioni periodiche dell'olio.

Per gli altri si consiglia di effettuare una prima sostituzione del lubrificante dopo circa 300 ore di funzionamento provvedendo ad un accurato lavaggio interno del gruppo con adeguati detersivi.

Evitare di miscelare olii a base minerale con olii sintetici.

Controllare periodicamente il livello del lubrificante effettuando la sostituzione indicativamente agli intervalli riportati nella tabella (A5).

(A5)

9 - MAINTENANCE

Life lubricated gearboxes do not require any periodical oil changes.

For other types of gearboxes, the first oil change must take place after about 300 hours of operation, carefully flushing the gear unit using suitable detergents.

Do not mix mineral oils with synthetic oils.

Check oil level regularly and change oil at the intervals shown in the table (A5).

9 - WARTUNG

Die mit Dauerschmierung gelieferten Getriebe bedürfen periodische Ölwechsel.

Bei den übrigen Getrieben wird ein erster Ölwechsel nach ca. 300 Betriebsstunden empfohlen, wobei das Innere der Gruppe sorgfältig mit einem geeigneten Reinigungsmittel zu waschen ist.

Mineralöle nicht mit Syntheseölen mischen.

Den Ölstand regelmäßig kontrollieren. Die Ölwechsel in den in der Tabelle (A5) angegebenen Fristen durchführen.

9 - ENTRETIEN

Les réducteurs fournis avec lubrification permanente n'ont besoin d'aucun remplacement périodique de huile.

Pour les autres, nous conseillons d'effectuer une première vidange du lubrifiant après les 300 premières heures de fonctionnement en réalisant un lavage soigné à l'intérieur du groupe avec des produits détergents appropriés.

Eviter de mélanger les huiles à base minérale avec des huiles synthétiques.

Contrôler périodiquement le niveau du lubrifiant en effectuant les vidanges conformément aux intervalles indiqués dans le tableau (A5).

Temperatura olio / Oil temperature Öltemperatur / Température huile [°C]	Intervallo di lubrificazione / Oil change interval Schmierfrist / Intervalle de lubrification [h]	
	olio minerale / mineral oil Mineralöl / huile minérale	olio sintetico / synthetic oil Syntheseöl / huile synthétique
< 65	8000	25000
65 - 80	4000	15000
80 - 95	2000	12500



10 - SELEZIONE

10 - SELECTION

10 - ANTRIEBSAUSWAHL

10 - SELECTION

Per selezionare correttamente un riduttore o un motorriduttore, è necessario disporre di alcuni dati fondamentali che sono sintetizzati nella tabella (A6). In particolare, essa potrà essere compilata ed inviata in copia al ns. Servizio Tecnico che provvederà alla ricerca della motorizzazione più idonea alla applicazione indicata.

Some fundamental data are necessary to assist the correct selection of a gearbox or gearmotor. The table below (A6) briefly sums up this information. To simplify selection, fill in the table and send a copy to our Technical Service which will select the most suitable drive unit for your application.

Um die Getriebe und Getriebe-motoren richtig auszuwählen zu können, muß man über einige grundlegende Daten verfügen, die wir in der Tabelle (A6) zusammengefaßt haben. Eine Kopie dieser vom Kunden ausgefüllten Tabelle kann an unseren Technischen Kundendienst geschickt werden, der dann die für die gewünschte Anwendung geeignete Auslegung wählt.

Pour sélectionner correctement un réducteur ou un motoréducteur, il est nécessaire de disposer de certaines données fondamentales que nous avons résumé dans le tableau (A6). En particulier, ce dernier pourra être rempli et retourné à notre service technique qui recherchera la motorisation la plus appropriée à l'application indiquée.

(A6)

Tipo di applicazione Type of application Anwendung Type d'application			
P ₂	Potenza in uscita a n ₂ max Output power at n ₂ max Abtriebsleistung bei n ₂ max Puissance en sortie à n ₂ maxikW	Senso di rotazione albero entrata (O-AO) (**) Input shaft rotation direction (CW-CCW) (**) Drehrichtung der Antriebswelle (U-GU) (**) Sens de rotation arbre entrée (H-AH) (**)
P ₂ '	Potenza in uscita a n ₂ min Output power at n ₂ min Abtriebsleistung bei n ₂ min Puissance en sortie à n ₂ minikW	A _{c1} Carico assiale su albero in uscita (+/-)(***) Thrust load on output shaft (+/-)(***) Axialkraft auf Abtriebswelle (+/-)(***) Charge axiale sur arbre de sortie (+/-)(***)
M ₂	Momento torcente in uscita a n ₂ max Output torque at n ₂ max Abtriebsdrehmoment bei n ₂ max Moment de torsion en sortie à n ₂ maxiNm	A _{c1} Carico assiale su albero in entrata (+/-)(***) Thrust load on input shaft (+/-)(***) Axialkraft auf Antriebswelle (+/-)(***) Charge axiale sur arbre d'entrée (+/-)(***)
n ₂	Velocità di rotazione in uscita max Max.output speed Abtriebsdrehzahl max Vitesse de rotation maxi en sortiemin ⁻¹	J _c Momento d'inerzia del carico Moment of inertia of the load Trägheitsmoment der Last Moment d'inertie de la charg
n ₂ '	Velocità di rotazione in uscita min Min.output speed Abtriebsdrehzahl min Vitesse de rotation mini en sortiemin ⁻¹	t _a Temperatura ambiente Ambient temperature Umgebungstemperatur Température ambiante
n ₁	Velocità di rotazione in entrata max Max.input speed Antriebsdrehzahl max Vitesse de rotation maxi en entréemin ⁻¹	Altitudine sul livello del mare Altitude above sea level Höhe ü.d.M. Altitude au-dessus du niveau de la mer
n ₁ '	Velocità di rotazione in entrata min Min.input speed Antriebsdrehzahl min Vitesse de rotation mini en entréemin ⁻¹	Tipo di servizio in accordo a CEI Duty type to IEC norms Relative Einschaltdauer gemäß CEI Type de service selon CE
R _{c2}	Carico radiale su albero in uscita Radial load on output shaft Radialkraft auf Abtriebswelle Charge radiale sur arbre de sortieN	Z Frequenza di avviamento Starting frequency Schaltungshäufigkeit Fréquence de démarrage
x ₂	Distanza di applicazione del carico (*) Load application distance (*) Abstand des Kraftangriffspunktes (*) Distance d'application de la charge (*)mm	Tensione di alimentazione motore Motor voltage Nennspannung des Motors Tension de alimentation moteur
	Orientamento del carico in uscita Load orientation at output Orientierung der Last am Abtrieb Orientation de la charge en sortie		Tensione di alimentazione freno Brake voltage Nennspannung der Bremse Tension de alimentation frein
	Senso di rotazione albero uscita (O-AO) (**) Output shaft rotation direction (CW-CCW) (**) Drehrichtung der Abtriebswelle (U-GU) (**) Sens de rotation arbre sortie (H-AH) (**)	Frequenza Frequency Frequenz Fréquence
R _{c1}	Carico radiale su albero in entrata Radial load on input shaft Radialkraft auf Antriebswelle Charge radiale sur arbre d'entréeN	M _b Coppia frenante Brake torque Bremsmoment Couple de freinag
x ₁	Distanza di applicazione del carico (*) Load application distance (*) Abstand des Kraftangriffspunktes (*) Distance d'application de la charge (*)mm	Grado di protezione motore Motor protection degree Schutzart des Motors Degré de protection moteur
	Orientamento del carico in entrata Load orientation at input Orientierung der Last am Antrieb Orientation de la charge en entrée		Classe di isolamento Insulation class Isolierstoffklasse Classe d'isolation

(*) La distanza x₁₋₂ è quella compresa fra il punto di applicazione della forza e la battuta dell'albero (se non indicata, si considererà la forza agente sulla mezziera della sporgenza dell'albero).
 (***) + = compressione
 - = trazione

(*) Distance x₁₋₂ is between force application point and shaft shoulder (if not indicated the force acting at mid-point of the shaft extension will be considered).
 (***) + = push
 - = pull

(*) Der Abstand x₁₋₂ ist der Abstand vom Kraftangriffspunkt zum Wellenansatz (wenn nicht anders angegeben, wird davon ausgegangen, daß die Kraft auf der Mitte des Wellenendes angreift).
 (***) + = Druck
 - = Zug

(*) La distance x₁₋₂ est celle comprise entre le point d'application de la force et l'épaulement de l'arbre (si non précisée l'on considerera la force agissant au milieu de la saillie de l'arbre).
 (***) H = sens horaire;
 AH = sens antihoraire
 (***) + = compression
 - = traction



Scelta dei motoriduttori	Selecting a gearmotor	Wahl des Getriebemotors	Sélection des motoréducteurs
---------------------------------	------------------------------	--------------------------------	-------------------------------------

- | | | | |
|--|---|--|---|
| <p>a) Determinare il fattore di servizio f_s in funzione del tipo di carico (fattore K), del numero di inserzioni/ora Z_r e del numero di ore di funzionamento.</p> <p>b) Dalla coppia M_{r2}, conoscendo n_2 e il rendimento η, ricavare la potenza in entrata.</p> | <p>a) <i>Determine service factor f_s according to type of duty (factor K), number of starts per hour Z_r and hours of operation.</i></p> <p>b) <i>From values of torque M_{r2}, speed n_2 and efficiency η the required input power can be calculated from the equation:</i></p> | <p>a) Den Betriebsfaktor f_s in Abhängigkeit von der Belastungsart (Faktor K), den Schaltungen /Stunde Z_r und den Betriebsstunden bestimmen.</p> <p>b) Aus dem Drehmoment M_{r2} mit ilfe der bekannten Werte für n_2 und dem Wirkungsgrad η die Antriebsleistung ableiten.</p> | <p>a) <i>Déterminer le facteur de service f_s en fonction du type de charge (facteur K), du nombre d'insertions/heure Z_r et du nombre d'heures de fonctionnement.</i></p> <p>b) <i>A partir du couple M_{r2}, en connaissant n_2 et le rendement η, calculer la puissance en entrée.</i></p> |
|--|---|--|---|

$$P_{r1} = \frac{M_{r2} \cdot n_2}{9550 \cdot \eta} \quad [\text{kW}] \quad (8)$$

Il valore di η per lo specifico riduttore può essere ricavato dal paragrafo 5.

Value of η for the captioned worm gear can be sorted out from paragraph 5.

Für das spezifische Getriebe kann der Wert η unter Paragraph 5 erhoben werden.

Il valeur de η pour le réducteur spécifique peut être calculée d'après les indications du paragraphe 5.

- | | | | |
|--|--|--|---|
| <p>c) Ricercare fra le tabelle dei dati tecnici motoriduttori quella corrispondente ad una potenza normalizzata P_n tale che:</p> | <p>c) <i>Consult the gearmotor selection charts and locate the table corresponding to normalised power P_n:</i></p> | <p>c) Unter den Tabellen mit den Technischen Daten der Getriebemotoren die Tabelle auswählen, die folgender Leistung entspricht:</p> | <p>c) <i>Rechercher parmi les tableaux des caractéristiques techniques des motoréducteurs celui correspondant à une puissance :</i></p> |
|--|--|--|---|

$$P_n \geq P_{r1} \quad (9)$$

Se non diversamente indicato, la potenza P_n dei motori riportata a catalogo si riferisce al servizio continuo S1. Per i motori utilizzati in condizioni diverse da S1, sarà necessario identificare il tipo di servizio previsto con riferimento alle Norme CEI 2-3/IEC 60034-1. In particolare, per i servizi da S2 a S8 e per le grandezze motore uguali o inferiori a 132, è possibile ottenere una maggiorazione della potenza rispetto a quella prevista per il servizio continuo, pertanto la condizione da soddisfare sarà:

Unless otherwise specified, power P_n of motors indicated in the catalogue refers to continuous duty S1. For motors used in conditions other than S1, the type of duty required by reference to CEI 2-3/IEC 60034-1 Standards must be mentioned. For duties from S2 to S8 in particular and for motor frame 132 or smaller, extra power output can be obtained with respect to continuous duty. Accordingly the following condition must be satisfied:

Wenn nicht anders angegeben, bezieht sich die im Katalog angegebene Leistung P_n der Motoren auf Dauerbetrieb S1. Bei Motoren, die unter anderen Bedingungen als S1 eingesetzt werden, muß die vorgesehene Betriebsart unter Bezug auf die CEI-Normen 2-3/IEC 60034-1 bestimmt werden. Insbesondere kann man für die Betriebsarten S2 bis S8 (und für Motorbaugrößen gleich oder niedriger als 132) eine Überdimensionierung der Leistung relativ zu der für den Dauerbetrieb vorgesehenen Leistung erhalten; die zu erfüllende Bedingung ist dann:

Sauf indication contraire la puissance P_n des moteurs indiquée dans le catalogue se réfère à un service continu S1. Pour les moteurs utilisés dans des conditions différentes du service S1, il sera nécessaire d'identifier le type de service prévu en se référant aux normes CEI 2-3/IEC 60034-1. En particulier, pour les services de type S2 à S8 ou pour les tailles de moteurs égales ou inférieures à 132 il est possible d'obtenir une majoration de la puissance par rapport à celle prévue pour le service continu. Par conséquent, la condition à satisfaire sera:

$$P_n \geq \frac{P_{r1}}{f_m} \quad (10)$$

Il fattore di maggiorazione f_m è ricavabile dalla tabella (A7).

The adjusting factor f_m can be obtained from table (A7).

Der Überdimensionierungsfaktor f_m kann der Tabelle (A7) entnommen werden.

Le facteur de majoration f_m peut être obtenu en consultant le tableau (A7).

Rapporto di intermittenza	Intermittence ratio	Relative Einschaltdauer	Rapport d'intermittence
----------------------------------	----------------------------	--------------------------------	--------------------------------

$$I = \frac{t_f}{t_f + t_r} \cdot 100 \quad (11)$$

t_f = tempo di funzionamento a carico costante
 t_r = tempo di riposo

t_f = work time at constant load
 t_r = rest time

t_f = Betriebszeit mit konstanter Belastung
 t_r = Aussetzzeit

t_f = temps de fonctionneent à charge constante
 t_r = temps de repos



(A7)

	SERVIZIO / DUTY / BETRIEB / SERVICE						S4 - S8 Interpellarci Please contact us Rückfrage Nous contacter
	S2			S3*			
	Durata del ciclo / Cycle duration [min] Zyklusdauer / Durée du cycle [min]			Rapporto di intermittenza / Cyclic duration factor (I) Relative Einschaltdauer / Rapport d'intermittence (I)			
f_m	10	30	60	25%	40%	60%	
	1.35	1.15	1.05	1.25	1.15	1.1	

* La durata del ciclo dovrà comunque essere uguale o inferiore a 10 minuti; se superiore interpellare il Servizio Tecnico di Bonfiglioli Riduttori.

* Cycle duration, in any event, must be 10 minutes or less. If it is longer, please contact our Technical Service.

* Die Zyklusdauer muß in jedem Fall kleiner oder gleich 10 min sein; wenn sie darüber liegt, unseren Technisch en Kundendienst zu Rate ziehen.

* La durée du cycle devra être égale ou inférieure à 10 minutes. Si supérieure, contacter notre Service Technique.

Nella sezione relativa alla potenza installata P_n , selezionare infine il motoriduttore che sviluppa la velocità di funzionamento più prossima alla velocità n_2 desiderata e per il quale il fattore di sicurezza S sia uguale, o superiore, al fattore di servizio f_s .

Next, refer to the appropriate P_n section within the gearmotor selection charts and locate the unit that features the desired output speed n_2 , or closest to, along with a safety factor S that meets or exceeds the applicable service factor f_s .

Als nächstes wählen Sie anhand der Getriebemotoren auswahltabellen den Abschnitt mit der entsprechenden P_n und suchen die gewünschte Abtriebsdrehzahl n_2 , oder die nächstmögliche Drehzahl, zusammen mit dem Sicherheitsfaktor S , der den zutreffenden Betriebsfaktor f_s erreicht oder überschreitet. Der Sicherheitsfaktor wird wie folgt berechnet:

Dans la section relative à la puissance installée P_n , sélectionner enfin le motoréducteur qui développe la vitesse de fonctionnement la plus proche à la vitesse n_2 désirée et pour lequel le facteur de sécurité S soit pareil, ou supérieur, au facteur de service f_s .

Il fattore di sicurezza è così definito:

The safety factor is so defined:

Le facteur de sécurité est défini ainsi :

$$S = \frac{Mn_2}{M_2} = \frac{Pn_1}{P_1} \quad (12)$$

Nelle tabelle di selezione motoriduttori gli abbinamenti sono sviluppati con motori a 2, 4 e 6 poli alimentati a 50 Hz. Per velocità di comando diverse da queste, effettuare la selezione con riferimento ai dati nominali forniti per i riduttori.

As standard, gear and motor combinations are implemented with 2, 4 and 6 pole motors, 50 Hz supplied. Should the drive speed be different from 2800, 1400 or 900 min-1, base the selection on the gear unit nominal rating.

Standardmäßig stehen Getriebemotorenkombinationen mit 2, 4 und 6 poligen Motoren für eine Frequenz von 50 Hz zur Verfügung. Sollten die Antriebsdrehzahlen abweichend von 2800, 1400 oder 900 min-1 sein, dann stützen Sie die Auslegung des Getriebes auf die Getriebeenddaten.

Dans les tableaux de sélection des motoréducteurs les accouplements sont développés avec moteurs à 2, 4 et 6 poles alimentés à 50 Hz. Pour vitesses de commande différentes à celles-ci, sélectionner suite aux données nominales fournies par les réducteurs.

Scelta dei riduttori e dei riduttori predisposti per motori IEC

Selecting a speed reducer or a gear unit with IEC motor adapter

Wahl des Getriebes und Getriebe für IEC-motoren

Sélection des réducteurs et des réducteurs CEI

- a) Determinare il fattore di servizio f_s .
- b) Conoscendo la coppia M_{r2} di uscita richiesta dalla applicazione, si procede alla definizione della coppia di calcolo:

- a) Determine service factor f_s .
- b) Assuming the required output torque for the application M_{r2} is known, the calculation torque can be then defined as:

- a) Den Betriebsfaktor f_s bestimmen.
- b) Anhand des bekannten von der Anwendung geforderten Abtriebsdrehmoments M_{r2} das Soll-Drehmoment bestimmen:

- a) Déterminer le facteur de service f_s .
- b) En connaissant le couple M_{r2} de sortie requis par l'application, l'on procède à la définition du couple de calcul :

$$M_{c2} = M_{r2} \cdot f_s \quad (13)$$

- c) In base alla velocità in uscita n_2 richiesta, e a quella in entrata n_1 disponibile, si calcola il rapporto di riduzione:

- c) The gear ratio is calculated according to requested output speed n_2 and input speed n_1 :

- c) Auf Grundlage der verlangten Abtriebsdrehzahl n_2 und der verfügbaren Antriebsdrehzahl n_1 die Übersetzungen berechnen:

- c) Suivant la vitesse en sortie n_2 requise et celle en entrée n_1 disponible, l'on calcule le rapport de réduction :

$$i = \frac{n_1}{n_2} \quad (14)$$

Disponendo dei dati M_{c2} e i , si ricercherà nelle tabelle corrispondenti alla velocità

Once values for M_{c2} and i are known consult the rating charts under the appropriate

Anhand der Werte für M_{c2} und i in den Tabellen für die Drehzahl n_1 das Getriebe

En disposant des données M_{c2} et i , l'on recherchera dans les tableaux correspon-



n_1 il riduttore che, in funzione del rapporto [i] più prossimo a quello calcolato, proponga una coppia nominale:

input speed n_1 and locate the gear unit that features the gear ratio closest to [i] and at same time offers a rated torque value M_{n2} so that:

auswählen, das in Abhängigkeit von einer Übersetzung [i], die dem Sollwert möglichst nahe ist, folgendes Nenn-Drehmoment erlaubt:

dant à la vitesse n_1 , le réducteur qui, en fonction du rapport [i] le plus proche de celui calculé, propose un couple nominal :

$$M_{n2} \geq M_{c2} \quad (15)$$

Se al riduttore scelto dovrà essere applicato un motore elettrico verificarne l'applicabilità consultando la tabella delle predisposizioni possibili paragrafo 24.

If a IEC normalized motor must be fitted check geometrical compatibility with the gear unit at paragraph 24 - Motor availability.

Wenn das Getriebe mit einem Elektromotor verbunden werden soll, die Verträglichkeit anhand der Tabelle der möglichen Anbaumöglichkeiten sicherstellen.

Au cas où il serait nécessaire d'appliquer un moteur électrique normalisé au réducteur choisi, en vérifier la possible adaptation en consultant le tableau des prédispositions possibles présenté.

11 - VERIFICHE

Effettuata la corretta selezione delle motorizzazioni, si consiglia di procedere alle seguenti verifiche:

a) Potenza termica

Assicurarsi che la potenza termica del riduttore, abbia un valore uguale o maggiore alla potenza richiesta dall'applicazione secondo la relazione (3) a pag. 6, in caso contrario selezionare un riduttore di grandezza superiore oppure provvedere ad applicare un sistema di raffreddamento forzato.

b) Coppia massima

Generalmente la coppia massima (intesa come punta di carico istantaneo) applicabile al riduttore non deve superare il 200% della coppia nominale M_{n2} ; verificare pertanto che tale limite non venga superato adottando, se necessario, opportuni dispositivi per la limitazione della coppia.

Per i motori trifase a doppia polarità è necessario rivolgere particolare attenzione alla coppia di commutazione istantanea che viene generata durante la commutazione dall'alta velocità alla bassa in quanto può essere decisamente più elevata della coppia massima stessa.

Un metodo semplice ed economico per ridurre tale coppia è quello di alimentare solo due fasi del motore durante la commutazione (il tempo di alimentazione a due fasi può essere regolato mediante un relè a tempo):

11 - VERIFICATION

After selection is complete it may be worth checking on the following:

a) Thermal capacity

Make sure that the thermal capacity of the gearbox is equal to or greater than the power required by the application according to equation (3) on page 6. If this condition is not verified, select a larger gearbox or apply a forced cooling system.

b) Maximum torque

The maximum torque (intended as momentary peak load) applicable to the gearbox must not, in general, exceed 200% of rated torque M_{n2} . Therefore, check that this limit is not exceeded, using suitable torque limiting devices, if necessary.

For three-phase double speed motors, it is important to pay attention to the switching torque which is generated when switching from high to low speed, because it could be significantly higher than maximum torque.

A simple, economical way to minimize overloading is to power only two phases of the motor during switch-over (power-up time on two phases can be controlled with a time-relay):

11 - PRÜFUNGEN

Nach Wahl des Getriebemotors folgende Prüfungen ausführen:

a) Thermische Grenzleistung

Sicherstellen, daß die Wärmeleistung des Getriebes größer oder gleich der verlangten Leistung ist, die von der Anwendung nach Gleichung (3) auf S. 6 verlangt wird. Andernfalls ein größer dimensioniertes Getriebe wählen bzw. ein Zwangskühlsystem vorsehen.

b) Max. Drehmoment

Im allgemeinen darf das max. Drehmoment (verstanden als momentane Lastspitze), das auf das Getriebe aufgebracht werden kann, 200 % des Nenndrehmoments M_{n2} nicht überschreiten. Sicherstellen, daß dieser Grenzwert nicht überschritten wird, und nötigenfalls die entsprechenden Vorrichtungen zur Begrenzung des Drehmoments vorsehen. Bei polumschaltbaren Drehstrommotoren muss dem Umschaltmoment, das beim Umschalten von der hohen auf die niedrige Drehzahl erzeugt wird, besondere Aufmerksamkeit geschenkt werden, da es entschieden größer sein kann als das Nenn-Drehmoment. Eine einfache und kostengünstige Methode zum Senken dieses Drehmoments besteht darin, daß nur zwei Phasen des Motors während des Umschaltens gespeist werden (die Dauer der Speisung von nur 2 Phasen kann durch ein Zeitrelais gesteuert werden):

11 - VERIFICATIONS

Après avoir effectué une sélection correcte des motorisations, nous conseillons de procéder aux vérifications suivantes :

a) Puissance thermique

S'assurer que la puissance thermique du réducteur ait une valeur supérieure ou égale à la puissance requise par l'application selon l'équation (3) page 6. Dans le cas contraire, sélectionner un réducteur de taille supérieure ou bien prévoir un système de refroidissement forcé.

b) Couple maximum

Généralement, le couple maximum (à considérer comme une pointe de charge instantanée) applicable au réducteur ne doit pas dépasser les 200% du couple nominal M_{n2} . Vérifier par conséquent que cette limite ne soit pas dépassée en adoptant, si nécessaire, des dispositifs adaptés pour limiter le couple.

Pour les moteurs triphasés à double polarité, il est nécessaire de prêter une attention particulière au couple de commutation instantané qui est généré lors du passage de la grande à la petite vitesse étant donné qu'il peut être considérablement plus élevé que le couple maximum lui même.

Une méthode simple et économique pour réduire ce couple consiste à alimenter seulement deux phases du moteur pendant la commutation (la durée d'alimentation sur deux phases peut être réglée au moyen d'un relais temporisateur) :



$$M_{g2} = 0.5 \cdot M_{g3}$$

M_{g2} = Coppia di commutazione alimentando 2 fasi

M_{g3} = Coppia di commutazione alimentando 3 fasi

Suggeriamo comunque di contattare il ns. Servizio Tecnico.

$$M_{g2} = 0.5 \cdot M_{g3}$$

M_{g2} = Switching torque with two-phase power-up

M_{g3} = Switching torque with three-phase power-up

We advise you, in any event, to contact our Technical Service.

$$M_{g2} = 0.5 \cdot M_{g3}$$

M_{g2} = Umschaltdrehmoment bei Speisung von 2 Phasen;

M_{g3} = Umschaltdrehmoment bei Speisung von 3 Phasen.

Wir empfehlen jedoch in jedem Fall, unseren Technischen Kundendienst zu Rate zu ziehen.

$$M_{g2} = 0.5 \cdot M_{g3}$$

M_{g2} = Couple de commutation en alimentant deux phases

M_{g3} = Couple de commutation en alimentant trois phases

Nous suggérons cependant de contacter notre Service Technique.

c) Carichi radiali

Verificare che i carichi radiali agenti sugli alberi di entrata e/o uscita rientrino nei valori di catalogo ammessi. Se superiori, aumentare la grandezza del riduttore oppure modificare la supportazione del carico.

Ricordiamo che tutti i valori indicati nel catalogo si riferiscono a carichi agenti sulla mezziera della sporgenza dell'albero in esame per cui, in fase di verifica, è indispensabile tenere conto di questa condizione provvedendo, se necessario, a determinare con le apposite formule il carico ammissibile alla distanza x_{1-2} desiderata.

A tale proposito si rimanda ai paragrafi relativi ai carichi radiali.

d) Carichi assiali

Anche gli eventuali carichi assiali dovranno essere confrontati con i valori ammissibili.

Se si è in presenza di carichi assiali molto elevati o combinati con carichi radiali, si consiglia di interpellare il ns. Servizio Tecnico.

e) Avviamenti orari

Per servizi diversi da S1, con un numero rilevante di inserzioni/ora si dovrà tener conto di un fattore Z (determinabile con le indicazioni riportate nel capitolo dei motori) il quale definisce il numero max. di avviamenti specifico per l'applicazione in oggetto.

c) Radial loads

Make sure that radial forces applying on input and/or output shaft are within permittend catalogue values.

If they were higher consider designing a different bearing arrangement before switching to a larger gear unit.

Catalogue values for rated overhung loads refer to mid-point of shaft under study.

Should application point of the overhung load be localised further out the revised loading capability must be adjusted as per instructions given in this manual. See paragraph 22.

d) Thrust loads

Actual thrust load must be found within 20% of the equivalent overhung load capacity.

Should an extremely high, or a combination of radial and axial load apply, consult Bonfiglioli Technical Service.

e) Starts per hour

For duties featuring a high number of switches the actual starting capability in loaded condition [Z] must be calculated. Actual number of starts per hour must be lower than value so calculated.

c) Radialkräfte

Sicherstellen, daß die auf die Antriebswellen und/oder Abtriebswellen wirkenden Radialkräfte innerhalb der zulässigen Katalogwerte liegen. Wenn sie höher sind, das Getriebe größer dimensionieren bzw. die Abstützung der Last verändern. Wir erinnern daran, daß alle im Katalog angegebenen Werte sich auf Kräfte beziehen, die auf die Mitte des Wellenendes wirken. Diese Tatsache muß bei der Prüfung unbedingt berücksichtigt werden und nötigenfalls muß mit Hilfe der geeigneten Formeln die zulässige Kraft beim gewünschten Abstand x_{1-2} bestimmt werden. Siehe hierzu die Erläuterungen zu den Radialkräften in diesem Katalog.

d) Axialkräfte

Auch die eventuell vorhandenen Axialkräfte müssen mit den im Katalog angegebenen zulässigen Werten verglichen werden. Wenn sehr hohe Axialkräfte wirken oder Axialkräfte in Kombination mit Radialkräften, bitte unseren Technischen Kundendienst zu Rate ziehen.

e) Schaltungen/Stunde

Bei anderen Betriebsarten als S1 mit einem hohen Wert für die Schaltungen/Stunde muß der Faktor Z berücksichtigt werden (er kann mit Hilfe der Angaben im Kapitel Motoren bestimmt werden), der die max. zulässige Anzahl von Schalten für eine bestimmte Anwendung definiert.

c) Charges radiales

Vérifier que les charges radiales agissant sur les arbres d'entrée et/ou de sortie se situent dans les valeurs de catalogue admises. Si elles sont supérieures, choisir la taille du réducteur supérieure ou modifier la reprise de charge. Rappelons que toutes les valeurs indiquées dans le catalogue se réfèrent à des charges agissant au milieu de la longueur disponible de l'arbre contrôlé. Par conséquent, en phase de vérification, il est indispensable de prendre en considération cette condition en déterminant, si nécessaire, avec les formules appropriées, la charge admissible à la distance x_{1-2} désirée. Se rapporter à ce propos aux paragraphes relatifs aux charges radiales.

d) Charges axiales

Les éventuelles charges axiales devront être comparées avec les valeurs admissibles. Si l'on est en présence de charges axiales très élevées ou combinées avec des charges radiales, nous conseillons d'interpeller notre Service Technique.

e) Démarrages/heure

Pour les services différents de S1, avec un nombre important d'insertions/heure, il faudra prendre en considération un facteur Z (déterminé à l'aide des informations reportées dans le chapitre des moteurs) qui définit le nombre maximum de démarrages spécifique pour l'application concernée.

12 - INSTALLAZIONE

È molto importante, per l'installazione del riduttore, attenersi alle seguenti norme:

a) Assicurarsi che il fissaggio del riduttore, sia stabile onde evitare qualsiasi vibrazione. Installare (se si prevedono

12 - INSTALLATION

The following installation instructions must be observed:

a) Make sure that the gearbox is correctly secured to avoid vibrations. If shocks or overloads are

12 - INSTALLATION

Für die Installation des Getriebes ist es äußerst wichtig, daß folgende Normen beachtet werden:

a) Sicherstellen, daß die Befestigung des Getriebes stabil ist, damit keine Schwingungen entstehen. Wenn es

12 - INSTALLATION

Il est très important, pour l'installation du réducteur, de se conformer aux règles suivantes:

a) S'assurer que la fixation du réducteur soit stable afin d'éviter toute vibration. Installer (en cas de chocs,



urti, sovraccarichi prolungati o possibili bloccaggi) giunti idraulici, frizioni, limitatori di coppia, ecc.

expected, install hydraulic couplings, clutches, torque limiters, etc.

voraussichtlich zu Stößen, längerdauernden Überlasten oder zu Blockierungen kommen kann, sind entsprechende Schutzelemente wie hydraulische Kupplungen, Kupplungen, Rutschkupplungen usw. zu installieren.

de surcharges prolongées ou de blocages) des couples hydrauliques, des embrayages, des limiteurs de couple etc...

- b) Durante la verniciatura si dovranno proteggere i piani lavorati e il bordo esterno degli anelli di tenuta per evitare che la vernice ne essichi la gomma, pregiudicando la tenuta del paraolio stesso.
- b) *Before being paint coated, the machined surfaces and the outer face of the oil seals must be protected to prevent paint drying out the rubber and jeopardising the sealing properties.*
- b) Beim Lackieren die bearbeiteten Flächen und die Dichtringe schützen, damit der Anstrichstoff nicht dem Kunststoff angreift und somit die Dichtigkeit der Ölabdichtungen in Frage gestellt wird.
- b) *En phase de peinture, il faudra protéger les plans usinés et le bord extérieur des bagues d'étanchéité pour éviter que la peinture ne dessèche le caoutchouc, ce qui risque de nuire à l'efficacité du joint.*
- c) Gli organi che vanno calettati sugli alberi di uscita del riduttore devono essere lavorati con tolleranza ISO H7 per evitare accoppiamenti troppo bloccati che, in fase di montaggio potrebbero danneggiare irreparabilmente il riduttore stesso. Inoltre, per il montaggio e lo smontaggio di tali organi si consiglia l'uso di adeguati tiranti ed estrattori utilizzando il foro filettato posto in testa alle estremità degli alberi.
- c) *Parts fitted on the gearbox output shaft must be machined to ISO H7 tolerance to prevent interference fits that could damage the gearbox itself. Further, to mount or remove such parts, use suitable pullers or extraction devices using the tapped hole located at the top of the shaft extension.*
- c) Die Organe, die mit einer Keilverbinding auf der Abtriebswelle des Getriebes befestigt werden, müssen mit einer Toleranz ISO H7 gearbeitet sein, um allzu fest blockierte Verbindungen zu vermeiden, die eventuell zu einer irreparablen Beschädigung des Getriebes während des Einbaus führen könnten. Außerdem sind beim Ein- und Ausbau dieser Organe geeignete Zugstangen und Abzieher zu verwenden, wobei die Gewindebohrung an den Köpfen der Wellen zu verwenden ist.
- c) *Les organes qui sont calés sur les arbres de sortie du réducteur doivent être réalisés avec une tolérance ISO H7 pour éviter les accouplements trop serrés qui, en phase de montage, pourraient endommager irrémédiablement le réducteur. En outre, pour le montage et le démontage de ces organes, nous conseillons d'utiliser un outillage et des extracteurs appropriés en utilisant le trou taraudé situé en extrémité d'arbre.*
- d) Le superfici di contatto dovranno essere pulite e trattate con adeguati protettivi prima del montaggio, onde evitare l'ossidazione e il conseguente bloccaggio delle parti.
- d) *Mating surfaces must be cleaned and treated with suitable protective products before mounting to avoid oxidation and, as a result, seizure of parts.*
- d) Die Berührungsflächen müssen sauber sein und vor der Montage mit einem geeigneten Schutzmittel behandelt werden, um Oxidierung und die daraus folgende Blockierung der Teile zu verhindern.
- d) *Les surfaces de contact devront être propres et traitées avec des produits de protections appropriés avant le montage afin d'éviter l'oxydation et par suite le blocage des pièces.*
- e) Prima della messa in servizio del riduttore accertarsi che la macchina che lo incorpora sia in regola con le disposizioni della Direttiva Macchine 89/392 e successivi aggiornamenti.
- e) *Prior to putting the gear unit into operation make sure that the equipment that incorporates the same complies with the current revision of the Machines Directive 89/392.*
- e) Bevor das Getriebe im Betrieb zu setzen, muß man sich vergewissern daß die das Getriebe einbauende Maschine gemäß den aktuellen Regelungen der Maschine Richtlinie 89/392 ist.
- e) *Avant la mise en service du réducteur, vérifier que la machine où il est monté est conforme aux normes de la Directive Machines 89/392 et ses mises à jour.*
- f) Prima della messa in funzione della macchina, accertarsi che la posizione del livello del lubrificante sia conforme alla posizione di montaggio del riduttore e che la viscosità sia adeguata al tipo del carico (vedi tabella A3).
- f) *Before starting up the machine, make sure that oil level conforms to the mounting position specified for the gear unit.*
- f) Vor Inbetriebnahme der Maschine sicherstellen, daß die Anordnung der Füllstandschraube der Einbaulage angemessen ist, und die Viskosität des Schmiermittels der Belastungsart entspricht (siehe Tabelle A3).
- f) *Avant la mise en marche de la machine, s'assurer que la position du niveau du lubrifiant soit conforme à la position de montage du réducteur et que la viscosité soit appropriée au type de charge (voir tableau A3).*
- g) Nel caso di installazione all'aperto prevede adeguate protezioni e/o carterature allo scopo di evitare l'esposizione diretta agli agenti atmosferici e alla radiazione solare.
- g) *For outdoor installation provide adequate guards in order to protect the drive from rainfalls as well as direct sun radiation.*
- g) Bei Inbetriebnahme in Frein, muß man geeigneten Schutzgeräte vorsehen, um das Antriebs gegen Regen und direkte Sonnenstrahlung zu schützen.
- g) *En cas d'installation en plein air, il est nécessaire d'appliquer des protections et/ou des caches appropriés de façon à éviter l'exposition directe aux agents atmosphériques et aux rayonnements solaires.*



13 - STOCCAGGIO

Il corretto stoccaggio dei prodotti ricevuti richiede l'esecuzione delle seguenti attività:

- a) Escludere aree all'aperto, zone esposte alle intemperie o con eccessiva umidità.
- b) Interporre sempre tra il pavimento ed i prodotti, pianali lignei o di altra natura, atti ad impedire il diretto contatto col suolo.
- c) Per periodi di stoccaggio e soste prolungate le superfici interessate agli accoppiamenti quali flange, alberi e giunti devono essere protette con idoneo prodotto antiossidante (Mobilarma 248 o equivalente). In questo caso i riduttori dovranno essere posizionati con il tappo di sfiato nella posizione più alta e riempiti interamente d'olio. Prima della loro messa in servizio nei riduttori dovrà essere ripristinata la corretta quantità, e il tipo di lubrificante.

13 - STORAGE

Observe the following instructions to ensure correct storage of the products:

- a) *Do not store outdoors, in areas exposed to weather or with excessive humidity.*
- b) *Always place wooden boards or other material underneath the product, to avoid the direct contact with the floor.*
- c) *In case of long-term storage all machined surfaces such as flanges, shafts and couplings must be coated with a suitable rust inhibiting product (Mobilarma 248 or equivalent). Furthermore gear units must be placed with the fill plug in the highest position and filled up with oil. Before putting the units into operation the appropriate quantity, and type, of oil must be restored.*

13 - LAGERUNG

Die korrekte Lagerung der Antriebe erfordert folgende Vorkehrungen:

- a) Die Produkte nicht im Freien lagern und nicht in Räumen, die der Witterung ausgesetzt sind, oder eine hohe Feuchtigkeit aufweisen.
- b) Die Produkte nie direkt auf dem Boden, sondern auf Unterlagen aus Holz oder einem anderen Material lagern.
- c) Bei anhaltenden Lager- und Haltszeiten müssen die Oberflächen für die Verbindung, wie Flansche, Wellen oder Kuppelungen mit einem geeigneten Oxidationsschutzmittel behandelt werden (Mobilarma 248 oder ein äquivalentes Mittel). Übrigens müssen die Getriebe mit nach oben gerichteter Entlüftungsschraube gelagert und mit Öl gefüllt werden. Die Getriebe müssen vor ihrer Verwendung mit der angegebenen Menge des vorgesehenen Schmiermittels gefüllt werden.

13 - STOCKAGE

Un correct stockage des produits reçus nécessite de respecter les règles suivantes :

- a) *Exclure les zones à ciel ouvert, les zones exposées aux intempéries ou avec humidité excessive.*
- b) *Interposer dans tous les cas entre le plancher et les produits des planches de bois ou des supports d'autre nature empêchant le contact direct avec le sol.*
- c) *Pour un stockage de long durée il faut protéger les surfaces d'accouplement (brides, arbres, manchon d'accouplement) avec produit anti oxydant (Mobilarma 248 ou équivalent). Dans ce cas les réducteurs devront être placés avec bouchon reniflard vers le haut et complètement rempli d'huile. Avant de la mise en service du réducteur, la bon quantité d'huile devra être rétabli selon la quantité indiquée sur le catalogue.*

14 - CONDIZIONI DI FORNITURA

I riduttori e i variatori vengono forniti come segue:

- a) già predisposti per essere installati nella posizione di montaggio come definito in fase di ordine;
- b) collaudati secondo specifiche interne;
- c) le superfici di accoppiamento non sono verniciate;
- d) provvisti di dadi e bulloni per montaggio motori per la versione IEC;
- e) dotati di protezioni in plastica sugli alberi;
- f) provvisti di golfare di sollevamento (dove previsto).

14 - CONDITIONS OF SUPPLY

Gear units are supplied as follows:

- a) *configured for installation in the mounting position specified when ordering;*
- b) *tested to factory specifications;*
- c) *mating machined surfaces unpainted;*
- d) *nuts and bolts for mounting motors are provided;*
- e) *shafts are protected;*
- f) *supplied with lifting lug (where applicable).*

14 - LIEFERBEDINGUNGEN

Die Getriebe und Verstellgetriebe werden in folgendem Zustand geliefert:

- a) schon bereit für die Montage in der bei Bestellung festgelegten Einbaulage;
- b) nach werksinternen Spezifikationen geprüft;
- c) die Verbindungsflächen sind nicht lackiert;
- d) ausgestattet mit Schrauben und Muttern für die Montage der Motoren (Version mit Adapter für IEC-Motoren);
- e) alle Getriebe werden mit Kunststoffschutz auf den Wellen geliefert;
- f) mit Transportriering zum Anheben (falls vorgesehen).

14 - CONDITIONS DE LIVRAISON

Les réducteurs et les variateurs sont livrés comme suit :

- a) *déjà prédisposés pour être installés dans la position de montage comme défini en phase de commande ;*
- b) *testés selon les spécifications internes ;*
- c) *les surfaces de liaison ne sont pas peintes ;*
- d) *équipés d'écrous et de boulons pour le montage des moteurs normalisés pour la version CEI ;*
- e) *embouts de protections en plastique sur les arbres ;*
- f) *dotés d'un crochet de levage (quand cela est prévu).*

15 - SPECIFICHE DELLA VERNICE

Le specifiche della vernice applicata sui riduttori (dove previsto) potranno essere richieste alle filiali o ai distributori che hanno fornito i gruppi.

15 - PAINT SPECIFICATIONS

Coating specifications for paint applied to gearboxes (where applicable) may be obtained from the branches or dealers that supplied the units.

15 - ANGABEN ZU DEN ANSTRICHSTOFFE

Die Spezifikationen des Lackes, der auf den Getriebe (wo erforderlich) verwendet wurde, können bei den Filialen oder Verkaufsstellen, die die Gruppen geliefert haben, angefordert werden.

15 - SPECIFICATIONS DE LA PEINTURE

Les spécification de la peinture appliquée sur les réducteurs pourront, le cas échéant, être demandées aux filiales ou aux distributeurs ayant fourni les groupes.

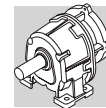

16 - FORME COSTRUTTIVE

16 - VERSIONS

16 - BAUFORMEN

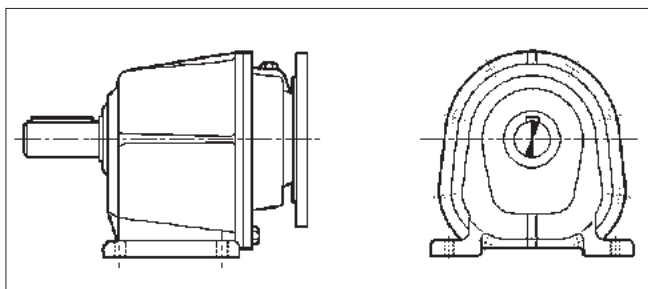
16 - FORMES DE
CONSTRUCTION**P**

Piedi integrali
Foot mount
Mit integrierten Füßen
Carter à pattes monobloc

AS 16...AS 90

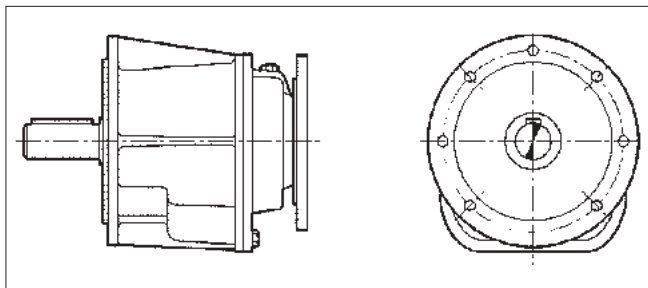
**F**

Flangia integrale
Flange mount
Mit integriertem Flansch
Carter à bride monobloc

AS 16...AS 90

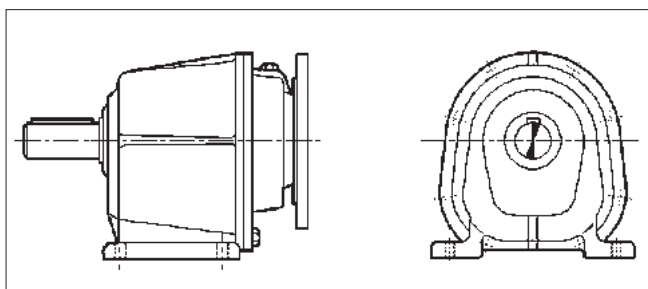
**PR**

Con piedi e cuscinetti rinforzati
Footed version with reinforced bearings
Mit verstärktem Füßen und Lagern
Avec pattes et roulements renforcés

AS 25...AS 30

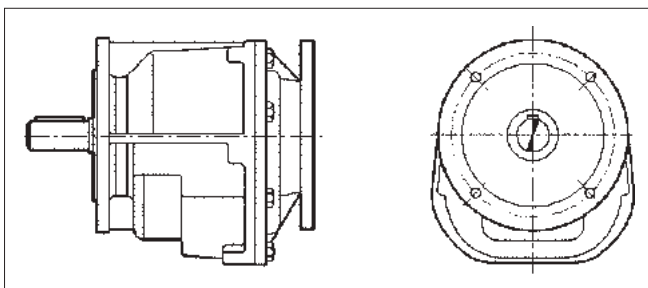
**R**

Flangia dimensioni ridotte e cuscinetti rinforzati
Flange reduced in diameter and reinforced bearings
Kleiner Flansch und verstärkte Lager
Bride dimensions réduites et roulements renforcés

AS 25...AS 30



PR, R: Le forme costruttive PR ed R garantiscono supportazioni radiali sull'albero lento maggiorate rispetto alle corrispondenti forme P ed F. Per informazioni sui valori puntuali contattare il Servizio Tecnico di Bonfiglioli.



PR, R: The PR and R designs provide greater overhung load capacity at the output shaft end than their P and F equivalents. Please contact Bonfiglioli Technical Service for precise values.



PR, R: Durch die Konstruktionsformen PR und R werden Radialkräfte auf der Abtriebswelle gewährleistet, die im Vergleich zu den entsprechenden Formen P und F höher sind. Für Informationen hinsichtlich der genauen Werte setzen Sie sich bitte mit dem Technischen Kundenservice von Bonfiglioli in Verbindung.



PR, R: Les formes de construction PR et R garantissent des caractéristiques de supports radiaux sur l'arbre de sortie majorés par rapport aux formes P et F correspondantes. Pour de plus amples informations concernant les valeurs exactes, contacter le Service Technique de Bonfiglioli.

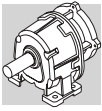

17 - DESIGNAZIONE

17 - DESIGNATION

17 - BEZEICHNUNG

17 - DESIGNATION

RIDUTTORE / GEAR UNIT
GETRIEBE / REDUCTEUR

AS 30 D P 65.80 _ 080 B5 B3

OPZIONI / OPTIONS
OPTIONEN / OPTIONS

LO (AS 45 ... AS 90)
PV (AS 16 ... AS 90)

20

POSIZIONE DI MONTAGGIO / MOUNTING POSITION
EINBAULAGEN / POSITION DE MONTAGE

AS_P B3 (default); B6; B7; B8; V5; V6

AS_F B5 (default); B51; B53; B52; V1; V3

23

FLANGIA ATTACCO MOTORE / MOTOR MOUNTING
MOTOR BAUFORM / BRIDE MOTEUR

B5

DESIGNAZIONE INGRESSO / INPUT CONFIGURATION
BEZEICHNUNG DER ANTRIEBSSEITE / DESIGNATION ENTREE

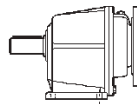

063	132
071	160
080	180
090	200
100	225
112	

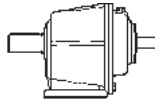
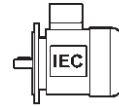

HS

Ø ALBERO / SHAFT / ANTRIEBSWELLE / ARBRE
(solo / only / nur für / seulement AS 16)

— (Ø16 default)
D14 (Ø14 option)

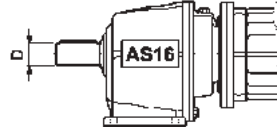

RAPPORTO / GEAR RATIO
ÜBERSETZUNG / RAPPORT DE REDUCTION

FORMA COSTRUTTIVA / VERSION / BAUFORM / FORME DE CONSTRUCTION

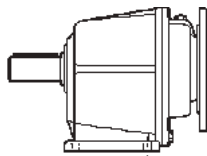

P

(AS16...AS90)

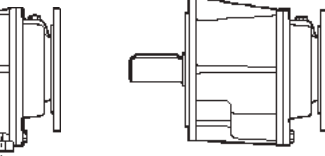

PR

(AS25-AS30)

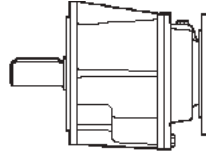

F

(AS16...AS90)

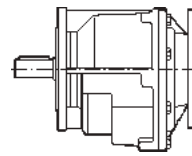

R

(AS25-AS35)

RIDUZIONI / REDUCTIONS / GETRIEBESTUFEN / ETAGES DE REDUCTION

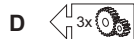
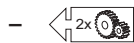







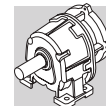

GRANDEZZA / FRAME SIZE / BAUGRÖSSE / TAILLE

16, 20, 25, 30, 35, 45, 55, 60, 80, 90

SERIE / GEARBOX TYPE / GETRIEBETYP / TYPE DU REDUCTEUR

AS



Designazione motore	Motor designation	Motor bezeichnung	Designation moteur
	MOTORE / MOTOR MOTOR / MOTEUR	FRENO / BRAKE BREMSE / FREIN	
BN	80B	4	230/400-50
	CLF	B5	FD
		10	R
			SB
			220SA
		
			OPZIONI OPTIONS OPTIONEN OPTIONS 
			ALIMENTAZ. FRENO BRAKE SUPPLY BREMSVERSORGUNG ALIMENTATION FREIN 
			TIPO ALIMENTATORE RECTIFIER TYPE GLEICHRICHTERTYP TYPE ALIMENTATEUR NB, SB, NBR, SBR 
			LEVA DI SBLOCCO FRENO BRAKE HAND RELEASE BRESENTHANDLÜFTUNG LEVIER DE DEBLOCAGE FREIN R, RM 
			COPPIA FRENANTE / BRAKE TORQUE BREMSMOMENT/ COUPLE FREIN   
			TIPO FRENO / BRAKE TYPE BRESENTYP / TYPE DE FREIN FD, FA, BA
			FORMA COSTRUTTIVA / MOTOR MOUNTING BAUFORM / FORM DE CONSTRUCTION B5
			CLASSE ISOLAMENTO / INSULATION CLASS ISOLIERUNGSKLASSE / CLASSE ISOLATION CL F standard CL H option
			TENSIONE - FREQUENZA / VOLTAGE - FREQUENCY SPANNUNG - FREQUENZ / TENSION - FREQUENCE
			NUMERO DI POLI / POLE NUMBER / POLZAHL / N.bre POLES 2, 4, 6, 2/4, 2/6, 2/8, 2/12, 4/6, 4/8
			GRANDEZZA MOTORE / MOTOR SIZE / MOTOR-BAUGRÖSSE / TAILLE MOTEUR 63A...280M
			TIPO MOTORE / MOTOR TYPE / MOTORTYP / TYPE MOTEUR BN

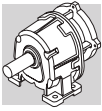

Opzioni riduttori

LO

I riduttori AS45, AS55, AS60, AS80, AS90 solitamente sprovvisti di lubrificante, sono richiesti con olio sintetico del tipo correntemente utilizzato da BONFIGLIOLI RIDUTTORI e riempiti in accordo alla posizione di montaggio richiesta.

PV

Tutti gli anelli di tenuta in Viton®.

Opzioni motori

AA, AC, AD

Posizione angolare leva di sblocco freno rispetto alla posizione morsettiera visto lato ventola.

Posizione standard = 90° orari.

AA = 0°, AC = 180°,

AD = 90° antiorari.

CF

Filtro capacitivo.

D3

No. 3 sonde bimetalliche.

E3

No. 3 termistori per motori a singola polarità e doppia polarità (in accordo alla classe di isolamento).

F1

Volano per avviamento progressivo.

H1

Riscaldatori anticondensa. Alimentazione standard 230V ± 10%.

PN

Potenza a 60 Hz corrispondente alla potenza normalizzata a 50 Hz.

PS

Doppia estremità d'albero (esclude opzione RC e U1).

RC

Tettuccio parapioggia (esclude opzione PS).

RV

Bilanciamento rotore in grado di vibrazione R.

TC

La variante del tettuccio tipo TC è da specificare quando il motore è installato in ambienti dell'industria tessile.

L'opzione esclude le varianti

Gearbox options

LO

Gearboxes AS45, AS55, AS60, AS80, AS90 usually supplied without oil, to be supplied with synthetic oil currently used by BONFIGLIOLI RIDUTTORI and filled according to the mounting position specified.

PV

Both input and output shafts feature Viton® oil seals.

Motor options

AA, AC, AD

Mutual position of the brake release lever and terminal box. View is from the fan side.

Standard position = 90° clockwise.

AA = 0°, AC = 180°,

AD = 90° counterclockwise.

CF

Capacitive filter.

D3

3 nos bimetallic thermostats.

E3

3 nos thermistors for single and double speed motors (according to the isolation class).

F1

Flywheel for soft start and stop.

H1

Anti condensate heaters. Standard voltage 230V ± 10%.

PN

60 Hz power corresponding to the normalized 50 Hz power.

PS

Double shaft extension (barring RC and U1 options).

RC

Drip cover (barring option PS).

RV

Rotor balancing in vibration class R.

TC

Option TC is a rain canopy variant for textile industry environments.

This option is not compatible with variants EN1, EN2, EN3

Getriebe Optionen

LO

Für Getriebe AS45, AS55, AS60, AS80, AS90 die gewöhnlich ohne Schmiermittel geliefert werden, in Übereinstimmung mit der Einbaulage gefüllt mit dem normalerweise von BONFIGLIOLI RIDUTTORI verwendeten synthetischen Schmierstoff.

PV

Alle Wellendichtringe aus Viton®.

Optionen Motoren

AA, AC, AD

geben die Lage des Bremslüfterhebels zum Klemmenkasten an. Standard ist 90° im Uhrzeigersinn beim Ansehen der Lüfterradseite.

AA = 0°, AC = 180°,

AD = 90° entgegen dem Uhrzeigersinn.

CF

Kapazitive filter.

D3

3 Bimetallfühler.

E3

3 Kaltleiterthermistoren für ein- oder zweipolige Motoren und polumschaltbaren Motoren (gemäß der Isolierstoffklasse).

F1

Schwungrad zum sanften Anfahren.

H1

Wicklungsheizung
Standardspannung 230 V ± 10%

PN

Die 60 Hz-Leistung wird an der 50 Hz-Normleistung ausgeglichen.

PS

Zweites Wellenende (schließt die Optionen RC und U1 aus).

RC

Schutzdach (schließt Option PS aus).

RV

Läufer in Vibrationsgrad R ausgewuchtet.

TC

Bei dieser Option handelt es sich um ein Schutzdach mit einem Textilnetz, dessen Einsatz empfohlen wird wenn der Motor in Bereichen der Textilindustrie instal-

Options réducteurs

LO

Les réducteurs AS45, AS55, AS60, AS80, AS90 habituellement dépourvus de lubrifiants, sont demandés avec huile synthétique du type couramment utilisé par BONFIGLIOLI RIDUTTORI et remplis conformément à la position de montage demandée.

PV

Toutes les bagues d'étanchéité en Viton®.

Options moteurs

AA, AC, AD

Position angulaire du levier de déblocage du frein par rapport à la position de la boîte à borne en regardant du côté du ventilateur.

Position standard = 90° sens horaire.

AA = 0°, AC = 180°,

AD = 90° sens anti-horaire.

CF

Filtre capacitif.

D3

3 sondes bimétalliques.

E3

3 thermistances pour moteurs à simple polarité ou double polarité (selon les classes d'isolation).

F1

Volant pour démarrage progressif.

H1

Réchauffeurs anticondensation. Alimentation standard 230V ± 10%.

PN

Puissance à 60 Hz correspondante à la puissance normalisée à 50 Hz.

PS

Double extrémité d'arbre (à l'exclusion de l'option RC et U1).

RC

Capot protection antipluie (option PS exclue).

RV

Équilibrage rotor avec degré de vibration R.

TC

La variante du capot type TC est à spécifier lorsque le moteur est installé dans des sites de l'industrie textile.

L'option exclue les variantes

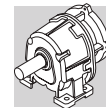

EN1, EN2, EN3 e non è applicabile ai motori con freno tipo BA.

and will not fit motors equipped with a BA brake.

liert wird. Diese Option schließt die Möglichkeit der Optionen EN1, EN2, EN3 aus und kann bei Bremsmotoren vom Typ BN_BA nicht montiert werden.

EN1, EN2, EN3 et n'est pas applicable aux moteurs avec frein type BA.

TP Tropicalizzazione.	TP <i>Tropicalization.</i>	TP Tropfenfestigkeit.	TP <i>Tropicalisation.</i>
U1 Servoventilazione (esclude opzioni PS e CUS).	U1 <i>Forced cooling (barring options PS and CUS).</i>	U1 Fremdbelüftung (Nicht anwendbare Gesamtheit an den Optionen PS und CUS).	U1 <i>Servo-ventilateur (Pas applicable ensemble aux options PS et CUS).</i>
U2 Servoventilatore privo di scatola morsettiera, dotato di cavi precablati internamente. Esclude le opzioni PS e CUS.. Disponibile per motori: BN 71 ... BN 132.	U2 <i>Separate supply forced ventilation without terminal box. Cables are pre-wired. Configuration is not compatible with options PS and CUS. Available on motors; BN 71 ... BN 132.</i>	U2 Servoventilator ohne Klemmenkasten, bereits intern verkabelt. Nicht anwendbare Gesamtheit an den Optionen PS und CUS. Verfügbar für folgende Motoren: BN 71 ... BN 132.	U2 <i>Servoventilateur sans boîte à bornes, doté de câbles précâblés à l'intérieur. Pas applicable ensemble aux options PS et CUS. Disponible pour moteurs : BN 71 ... BN 132.</i>

18 - LUBRIFICAZIONE

18 - LUBRICATION

18 - SCHMIERUNG

18 - LUBRIFICATION

I riduttori AS delle grandezze 16, 20, 25, 30 e 35 sono riempiti in fabbrica con carica di lubrificante sintetico "a vita" del tipo SHELL Tivela S 320.

The AS speed reducers sizes 16, 20, 25, 30 and 35 are factory filled with long-life synthetic lubricant, SHELL Tivela S 320.

Die Getriebe der Serie AS in den Baugrößen 16, 20, 25, 30 und 35 sind bereits auf Lebenszeit „long life“ ab Werk mit einem synthetischen Schmiermittel von Typ SHELL Tivela S 320 gefüllt.

Pour les réducteurs AS des tailles 16, 20, 25, 30 et 35 le premier remplissage est effectué par les établissements Bonfiglioli avec du lubrifiant synthétique du type "long life", SHELL Tivela S 320.

Non sono pertanto richiesti interventi periodici di sostituzione del lubrificante.

There is no need for periodical lubricant changes.

Daher sind keinerlei regelmäßige Auswechseleingriffe des Schmiermittels erforderlich.

Le lubrifiant particulier adopté de série ne nécessite aucune vidange périodique.

I riduttori sono allestiti in esecuzione sigillata e pertanto privi di tappi di carico, scarico e livello. La quantità di olio è tale da consentire l'installazione di questi gruppi in qualsiasi posizione di montaggio.

The reducers are sealed, therefore they feature no fill, drain and level plugs. Oil quantity allows any mounting position.

Die Getriebe sind versiegelt und verfügen über keinerlei Einfüll-, Ablass und Pegelstandsschrauben. Die Ölmenge ist so ausgelegt, dass diese Gruppen in allen Einbaulagen installiert werden können.

Les réducteurs sont scellés, par conséquent, ne sont pas équipés de bouchons de remplissage, vidange et niveau.

Il funzionamento dei riduttori è ammesso per temperature ambiente comprese fra -20°C e +40°C. Per temperature ambiente comprese fra -20°C e -10°C l'avviamento del riduttore potrà avvenire solo dopo aver effettuato un pre-riscaldamento progressivo ed omogeneo del gruppo, oppure con funzionamento "a vuoto", senza carico collegato.

Operation of gear units is permitted at ambient temperatures between -20°C and +40°C. However, for temperatures between -20°C and -10°C unit may only start up after it has been progressively and evenly pre-heated, or otherwise initially operated unloaded.

Die Getriebe dürfen bei einer Umgebungstemperatur von -20°C bis +40°C betrieben werden. Allerdings darf ein Start unter Last bei -20°C bis -10°C erst nach stufenweiser und gleichmäßiger Vorwärmung erfolgen. Anderfalls muss das Anfahren ohne Last erfolgen.

La quantité d'huile utilisée permet d'installer ces groupes dans toute position de montage. Le fonctionnement des réducteurs est admis pour des températures ambiantes comprises entre -20°C et +40°C.

Il carico potrà poi essere applicato all'albero del riduttore quando la temperatura dello stesso avrà raggiunto la temperatura di -10°C, o superiore.

Load may then be connected to the output shaft when the gear unit has reached the temperature of -10°C, or higher.

Die Last darf erst zugeschaltet werden, wenn die Getriebeeinheit eine Temperatur von mindestens -10° oder höher erreicht hat.

Pour des températures ambiantes comprises entre -20°C et -10°C le démarrage du réducteur est admis seulement après un préchauffage progressif et homogène, ou avec un fonctionnement « à vide », sans charge appliquée. La charge pourra être ensuite appliquée à l'arbre du réducteur quand celui-ci aura atteint une température de -10°C, ou supérieure.

Se, per qualsiasi motivo, si dovesse procedere alla completa sostituzione della carica originaria di lubrificante, la tabella seguente fornisce le quantità da immettere.

Should you carry out, for any reason, the complete change of the original lubricant, the following table indicates quantity to be used.

Sollte es aus irgendeinem Grund erforderlich sein die gesamte ursprüngliche Schmiermittelfüllung auszuwechseln zu müssen, bitten wir Sie dabei Bezug auf die nachstehende Tabelle zu nehmen.

Si, pour une raison quelconque, il est nécessaire de vidanger complètement la charge de lubrifiant, vérifier dans le tableau qui suit les quantités à utiliser pour le remplissage.

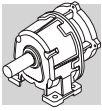

(A8)

	[l]
AS 16	0.36
AS 20	0.60
AS 25	0.75
AS 30	1.50
AS 35	1.50

I riduttori delle grandezze 45, 55, 60, 80 e 90 sono invece dotati di tappi per il carico, scarico e controllo del livello dell'olio e sono normalmente forniti privi di lubrificante.

Sarà quindi cura del Cliente immettere nel riduttore il corretto quantitativo di lubrificante, prima della sua messa in servizio.

La tabella che segue fornisce la quantità indicativa da inserire nel riduttore, in funzione della sua posizione di montaggio.

Il livello corretto è comunque sempre rappresentato dalla mezzeria del vetro-spia presente sul riduttore.

N.B. Specificare sempre nell'ordine la posizione di montaggio del riduttore.

Sizes 45, 55, 60, 80 and 90 are equipped with fill, drain and level plugs. The speed reducer is supplied unlubricated and the oil shall be filled by the Customer before start-up. The table below indicates the approximate quantity to be filled in the reducer, according to its mounting position.

Correct level is at mid height of the sight glass.

NOTE: When ordering, always indicate the reducer mounting position.

Die Getriebe in den Baugrößen 45, 55, 60, 80 und 90 sind dagegen mit Einfüll-, Ablass und Pegelstandsrauben ausgestattet und werden normalerweise ohne Schmiermittelfüllung geliefert.

Der Kunde muss daher vor einer Inbetriebnahme die korrekte Schmiermittelmenge in diese Getriebe füllen.

In der nachstehenden Tabelle werden Anhaltsmengen angegeben, die je nach entsprechender Einbaulage, in die Getriebe zu füllen sind.

Der korrekt Schmiermittelpiegel ist jedoch dann erreicht, wenn er die Mitte am Schauglas des Pegelstands des Getriebes erreicht hat.

HINWEIS: Im Auftrag immer die Einbaulage des Getriebes angeben.

Dans les tailles 45, 55, 60, 80 et 90, le réducteur est livré sans huile et est doté de bouchons de service pour le remplissage, la vidange et le niveau de lubrifiant.

L'utilisateur doit se charger de le remplir en huile avant la mise en service.

Le tableau qui suit indique la quantité indicative à introduire dans le réducteur, selon la position de montage.

Pour un remplissage correct, prendre comme référence la moitié de l'hublot transparent.

N.B. : Dans la commande, toujours spécifier la position de montage du réducteur.

(A9)

	B3 B5	B6 B51	B7 B53	B8 B52	V5 V1	V6 V3
AS 45	2.4	2.2	2.2	1.8	2.7	3.6
AS 55	2.9	2.8	2.8	3.8	6.0	5.5
AS 60	5.5	6.0	6.0	6.5	9.0	8.0
AS 80	9.3	11.3	11.3	11.4	17.8	17.2
AS 90	15.5	17.3	17.3	17.3	29	26.2

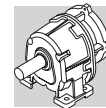

19 - POSIZIONI DI MONTAGGIO E ORIENTAMENTO MORSETTIERA

19 - MOUNTING POSITION AND TERMINAL BOX ANGULAR POSITION

19 - EINBAULAGEN UND LAGE DES KLEMMENKASTENS

19 - POSITIONS DE MONTAGE ET ORIENTATION BOITE A BORNE

Gli orientamenti delle morsettiere dei motori sono identificati osservando il motore dal lato ventola; l'orientamento standard è evidenziato in nero (W), come indicato nella tabella (A10).

Location of motor terminal boxes can be specified by viewing the motor from the fan side; standard location is highlighted in bold (W), as in table (A10).

Die Angaben zur Lage des Klemmenkastens beziehen sich auf das von der Lüfterseite her betrachtete Getriebe. Die Standardorientierung ist schwarz hervorgehoben (W), wie in Abbildung (A10) angegeben.

Les orientations des boîtes à bornes des moteurs sont définies en regardant le moteur du côté ventilateur. L'orientation standard est indiquée en noir (W), comme d'après le tableau (A10).

(A10)

P PR	<p>B3</p>	<p>B8</p>	<p>V5</p>	<p>V6</p>
	<p>B6</p>	<p>B7</p>		
F R	<p>B5</p>	<p>B52</p>	<p>V1</p>	<p>V3</p>
	<p>B51</p>	<p>B53</p>		

Posizione angolare leva di sblocco freno.

Nei motori autofrenanti, la leva di sblocco freno (se richiesta) ha l'orientamento standard a 90° rispetto alla morsettiere (posizione AB); specificare con relative opzioni qualora l'orientamento desiderato sia diverso.

Angular position of the brake release lever.

In brake motors the brake release lever (if requested) is 90° standard orientated with respect to the terminal box (position AB); different orientations must be specified when ordering by means of the proper option.

Winkellage des Handlüfterhebels.

Bei Bremsmotoren wird der Handlüfterhebel (auf Anfrage) standardmäßig auf 90° gegenüber des Klemmkastens (AB-Anordnung) geliefert; wird eine andere Anordnung verlangt, muß dies bei der Bestellung durch das geeignete Option angegeben werden.

Position angulaire levier déblocage frein.

Dans les moteurs freins, ce levier (si requis) aura l'orientation standard de 90° par rapport à la boîte à bornes (position AB); spécifier avec options relatives si l'orientation désirée est diffé-

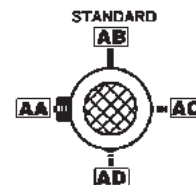

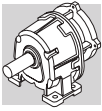

20 - CARICHI RADIALI

Organi di trasmissione calettati sugli alberi di ingresso e/o di uscita del riduttore generano forze la cui risultante agisce in senso radiale sull'albero stesso. L'entità di questi carichi deve essere compatibile con la capacità di sopportazione del sistema albero-cuscinetti del riduttore, in particolare il valore assoluto del carico applicato (R_{c1} per albero di ingresso, R_{c2} per albero di uscita) deve essere inferiore al valore nominale (R_{n1} per albero di ingresso, R_{n2} per albero di uscita) riportato nelle tabelle dati tecnici.

Nelle formule che seguono l'indice (1) si riferisce a grandezza relative all'albero veloce, l'indice (2) all'albero lento. Il carico generato da una trasmissione esterna può essere calcolato, con buona approssimazione, tramite la formula seguente:

20 - OVERHUNG LOADS

External transmissions keyed onto input and/or output shaft generate loads that act radially onto same shaft. Resulting shaft loading must be compatible with both the bearing and the shaft capacity. Namely shaft loading (R_{c1} for input shaft, R_{c2} for output shaft), must be equal to or lower than admissible overhung load capacity for shaft under study (R_{n1} for input shaft, R_{n2} for output shaft). OHL capability listed in the rating chart section.

In the formulas given below, index (1) applies to parameters relating to input shaft, whereas index (2) refers to output shaft. The load generated by an external transmission can be calculated with close approximation through the following equations:

20 - RADIALKRÄFTE

Die mit den Antriebs- und/oder Abtriebswellen des Getriebes verbundenen Antriebsorgane bilden Kräfte, die in radiale Richtung auf die Welle selbst wirken. Das Ausmaß dieser Kräfte muß mit der Festigkeit des Systems aus Getriebewelle/-lager kompatibel sein, insbesondere muß der absolute Wert der angetragenen Belastung (R_{c1} für Antriebswelle und R_{c2} für Abtriebswelle) unter dem in den Tabellen der Technischen Daten angegebenen Nennwert (R_{n1} für Antriebswelle und R_{n2} für Abtriebswelle) liegen.

In den nachstehenden Formeln bezieht sich die Angabe (1) auf die Maße der Antriebswelle, die Angabe (2) auf die Abtriebswelle. Die von einem externen Antrieb erzeugte Kraft kann, recht genau, anhand der nachstehenden Formel berechnet werden:

20 - CHARGES RADIALES

Les organes de transmission caillés sur les arbres d'entrée et/ou de sortie du réducteur génèrent des forces dont la résultante agit sur l'arbre dans le sens radial. L'entité de ces charges doit être compatible avec la capacité d'endurance du système arbre-roulements du réducteur. Plus particulièrement, la valeur absolue de la charge appliquée (R_{c1} pour l'arbre d'entrée, R_{c2} pour l'arbre de sortie) doit être inférieure à la valeur nominale (R_{n1} pour l'arbre d'entrée, R_{n2} pour l'arbre de sortie) indiquée dans les tableaux des données techniques.

Dans les formules qui suivent, l'indice (1) se réfère à des tailles relatives à l'arbre rapide, l'indice (2) concerne l'arbre lent. La charge générée par une transmission extérieure peut être calculée, avec une bonne approximation, au moyen de la formule suivante :

$$R_{c1} [N] = \frac{2000 \times M_1 [Nm] \times K_r}{d [mm]} ; R_{c2} [N] = \frac{2000 \times M_2 [Nm] \times K_r}{d [mm]} \quad (16)$$

dove:

$M_{1-2} [Nm]$ = coppia applicata all'albero

$d [mm]$ = diametro primitivo organo calettato

$K_r = 1$ trasmissione con catena

$K_r = 1.25$ trasmissione ad ingranaggio

$K_r = 1.5-2.0$ trasmissione a cinghia

where:

$M_{1-2} [Nm]$ = torque applied to shaft

$d [mm]$ = pitch diameter of part keyed on to shaft

$K_r = 1$ chain transmission

$K_r = 1.25$ gear transmission

$K_r = 1.5-2.0$ belt transmission

dabei:

$M_{1-2} [Nm]$ = Drehmoment an der Welle

$d [mm]$ = Teilkreisdurchmesser des aufgekeilten Organs

$K_r = 1$ Kettenantrieb

$K_r = 1.25$ Zahnradantrieb

$K_r = 1.5-2.0$ Antrieb über Keilriemen

où:

$M_{1-2} [Nm]$ = couple appliqué à l'arbre

$d [mm]$ = diamètre primitif organe calé

$K_r = 1$ transmission avec chaîne

$K_r = 1.25$ transmission à engrenage

$K_r = 1.5-2.0$ transmission à courroie

Il carico precedentemente calcolato si dovrà confrontare con il corrispondente valore nominale esposto a catalogo e dovrà verificarsi:

$R_{c1} \leq R_{n1}$ [albero veloce]

oppure

$R_{c2} \leq R_{n2}$ [albero lento]

A comparison of shaft loading with catalogue OHL ratings should verify the following condition:

$R_{c1} \leq R_{n1}$ [input shaft]

or

$R_{c2} \leq R_{n2}$ [output shaft]

Der zuvor errechnete Wert muß mit dem im Katalog angegebenen Nennwert verglichen werden. Es muß sich folgendes ergeben:

$R_{c1} \leq R_{n1}$ [Antriebswelle]

oder

$R_{c2} \leq R_{n2}$ [Abtriebswelle]

La charge précédemment calculée doit être comparée avec la valeur nominale correspondante indiquée dans le catalogue, on doit vérifier :

$R_{c1} \leq R_{n1}$ [arbre rapide]

ou

$R_{c2} \leq R_{n2}$ [arbre lent]

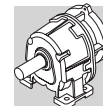

21 - CARICHI ASSIALI,

A_{n1}, A_{n2}

I valori di carico assiale ammissibile sugli alberi veloce $[A_{n1}]$ e lento $[A_{n2}]$ si possono ricavare con riferimento al corrispondente valore di carico radiale $[R_{n1}]$ e $[R_{n2}]$ tramite le espressioni che seguono:

21 - THRUST LOADS,

A_{n1}, A_{n2}

Permissible thrust loads on input $[A_{n1}]$ and output $[A_{n2}]$ shafts are obtained from the radial loading for the shaft under consideration $[R_{n1}]$ and $[R_{n2}]$ through the following equation:

21 - AXIALKRÄFTE,

A_{n1}, A_{n2}

Die Werte der zulässigen, auf die Antriebswelle $[A_{n1}]$ und auf die Abtriebswelle $[A_{n2}]$ einwirkenden Axialkräfte können unter Bezugnahme auf den jeweiligen Wert der Radialkraft $[R_{n1}]$ und $[R_{n2}]$ anhand der nachstehenden Angaben berechnet werden:

21 - CHARGES AXIALES,

A_{n1}, A_{n2}

Les valeurs de charge axiale admissible sur les arbres rapides $[A_{n1}]$ et lent $[A_{n2}]$ peuvent être calculées, en se référant à la valeur de charge radiale correspondante $[R_{n1}]$ et $[R_{n2}]$ au moyen des formules suivantes :

$$A_{n1} = R_{n1} \times 0.2$$

$$A_{n2} = R_{n2} \times 0.2$$

(17)

I valori di carico assiale ammissibile così calcolati si riferiscono al caso di forze assiali agenti contemporaneamente ai carichi radiali nominali.

Nel solo caso in cui il valore del carico radiale agente sull'albero del riduttore sia nullo, si può considerare il carico assiale ammissibile $[A_n]$ pari al 50% del valore di carico radiale ammissibile $[R_n]$ sullo stesso albero.

In presenza di carichi assiali eccedenti il valore ammissibile, o di forze assiali fortemente prevalenti sui carichi radiali, è consigliabile contattare il Servizio Tecnico di Bonfiglioli Riduttori per una verifica puntuale.

The thrust loads calculated through these formulas apply to thrust forces occurring simultaneously to time as rated radial loads.

In the only case that no overhung load acts on the shaft the value of the admissible thrust load $[A_n]$ amounts to 50% of rated OHL $[R_n]$ on same shaft.

Where thrust loads exceed permissible value or largely prevail over radial loads, contact Bonfiglioli Riduttori for an in-depth analysis of the application.

Die so errechneten Werte der zulässigen Axialkräfte beziehen sich auf den Fall, in dem die Axialkräfte gleichzeitig mit den Nennradialkräften einwirken.

Nur im Fall, es keine Radialbelastung auf die Getriebewelle gibt, ist der Wert der zulässigen Axialbelastung $[A_n]$ gleich zu 50% der zulässigen Radialbelastung $[R_n]$ auf die gleiche Welle. In Anwesenheit von übermäßigen Axialkräften, oder stark auf die Radialkräfte einwirkende Kräfte, wird im Hinblick auf eine genaue Kontrolle empfohlen, sich mit dem Technischen Kundendienst der Bonfiglioli Riduttori in Verbindung zu setzen.

Les valeurs de charge axiale admissible ainsi calculées se réfèrent au cas de forces axiales agissant en même temps que les charges radiales nominales.

Dans le seul cas la valeur de la charge radiale agissant sur l'arbre soit nul, l'on peut considérer la charge axiale admissible $[A_n]$ égale à 50% de la valeur de la charge radiale admissible $[R_n]$ sur le même arbre.

En présence de charges axiales excédant la valeur admissible, ou de forces axiales fortement supérieures aux charges radiales, il est conseillé de contacter le Service Technique Bonfiglioli Riduttori pour une vérification.

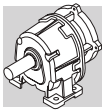

0.09 kW

n_2 min ⁻¹	M_2 Nm	S	i	Rn_2 N	IEC		
4.7	169	1.2	192.1	3200	AS 25 D_063 B5	BN 63A 6	74
5.8	139	1.4	157.9	3200	AS 25 D_063 B5	BN 63A 6	74
6.3	127	1.6	144.4	3200	AS 25 D_063 B5	BN 63A 6	74
7.4	108	1.9	122.5	3200	AS 25 D_063 B5	BN 63A 6	74
7.6	105	0.9	120.1	2800	AS 20 D_063 B5	BN 63A 6	72
8.3	96	2.1	109.1	3200	AS 25 D_063 B5	BN 63A 6	74
8.4	95	1.1	108.1	2800	AS 20 D_063 B5	BN 63A 6	72
9.3	86	1.2	97.7	2800	AS 20 D_063 B5	BN 63A 6	72
10.1	79	2.5	89.7	3200	AS 25 D_063 B5	BN 63A 6	74
11.1	72	2.8	82	3200	AS 25 D_063 B5	BN 63A 6	74
11.2	72	1.4	81.4	2800	AS 20 D_063 B5	BN 63A 6	72
13.1	61	3.3	69.6	3200	AS 25 D_063 B5	BN 63A 6	74
13.1	61	1.6	69.2	2800	AS 20 D_063 B5	BN 63A 6	72
14.2	56	1.8	64.3	2800	AS 20 D_063 B5	BN 63A 6	72
15.7	51	2.0	58.1	2800	AS 20 D_063 B5	BN 63A 6	72
18.4	44	2.0	49.52	2800	AS 20_063 B5	BN 63A 6	72
20.3	40	2.2	44.77	2800	AS 20_063 B5	BN 63A 6	72
20.3	40	1.1	44.73	1170	AS 16_063 B5	BN 63A 6	70
22.6	36	1.2	40.32	1150	AS 16_063 B5	BN 63A 6	70
24.4	33	2.7	37.31	2800	AS 20_063 B5	BN 63A 6	72
25.0	33	1.4	36.36	1140	AS 16_063 B5	BN 63A 6	70
27.8	29	1.5	32.78	1110	AS 16_063 B5	BN 63A 6	70
28.7	28	3.2	31.71	2790	AS 20_063 B5	BN 63A 6	72
32	25	3.6	28.13	2710	AS 20_063 B5	BN 63A 6	72
34	24	1.8	27.14	1070	AS 16_063 B5	BN 63A 6	70
36	23	3.9	25.43	2630	AS 20_063 B5	BN 63A 6	72
43	19	2.4	20.96	1020	AS 16_063 B5	BN 63A 6	70
48	17	2.7	18.89	1000	AS 16_063 B5	BN 63A 6	70
58	14	3.2	15.64	950	AS 16_063 B5	BN 63A 6	70
73	11	4.0	12.47	900	AS 16_063 B5	BN 63A 6	70
81	10	4.5	11.24	880	AS 16_063 B5	BN 63A 6	70
98	8	5.4	9.31	830	AS 16_063 B5	BN 63A 6	70
123	7	6.8	7.41	780	AS 16_063 B5	BN 63A 6	70
136	6	7.5	6.68	760	AS 16_063 B5	BN 63A 6	70
164	5	9.1	5.53	720	AS 16_063 B5	BN 63A 6	70

0.12 kW

5.8	185	1.1	157.9	3200	AS 25 D_063 B5	BN 63B 6	74
6.3	169	1.2	144.4	3200	AS 25 D_063 B5	BN 63B 6	74
7.3	146	1.2	192.1	3200	AS 25 D_063 B5	BN 63A 4	74
7.4	144	1.4	122.5	3200	AS 25 D_063 B5	BN 63B 6	74
8.3	128	1.6	109.1	3200	AS 25 D_063 B5	BN 63B 6	74
8.9	120	1.5	157.9	3200	AS 25 D_063 B5	BN 63A 4	74
9.7	110	1.6	144.4	3200	AS 25 D_063 B5	BN 63A 4	74
10.1	105	1.9	89.7	3200	AS 25 D_063 B5	BN 63B 6	74
11.1	96	2.1	82	3200	AS 25 D_063 B5	BN 63B 6	74
11.2	95	1.0	81.4	2800	AS 20 D_063 B5	BN 63B 6	72
11.4	93	1.9	122.5	3200	AS 25 D_063 B5	BN 63A 4	74
11.7	91	1.0	120.1	2800	AS 20 D_063 B5	BN 63A 4	72
12.8	83	2.2	109.1	3200	AS 25 D_063 B5	BN 63A 4	74
13.0	82	1.1	108.1	2800	AS 20 D_063 B5	BN 63A 4	72
13.1	82	2.5	69.6	3200	AS 25 D_063 B5	BN 63B 6	74
13.1	81	1.2	69.2	2800	AS 20 D_063 B5	BN 63B 6	72
14.2	75	1.3	64.3	2800	AS 20 D_063 B5	BN 63B 6	72

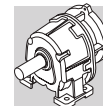

0.12 kW

n_2 min ⁻¹	M_2 Nm	S	i	Rn_2 N		
14.3	74	1.2	97.7	2800	AS 20 D_063 B5 BN 63A 4	72
15.6	68	2.6	89.7	3200	AS 25 D_063 B5 BN 63A 4	74
17.1	62	2.9	82	3200	AS 25 D_063 B5 BN 63A 4	74
17.2	62	1.5	81.4	2800	AS 20 D_063 B5 BN 63A 4	72
20.1	53	3.4	69.6	3200	AS 25 D_063 B5 BN 63A 4	74
20.2	53	1.7	69.2	2800	AS 20 D_063 B5 BN 63A 4	72
21.8	49	1.8	64.3	2800	AS 20 D_063 B5 BN 63A 4	72
24.1	44	2.0	58.1	2800	AS 20 D_063 B5 BN 63A 4	72
28.3	39	2.1	49.52	2740	AS 20_063 B5 BN 63A 4	72
31	35	2.3	44.77	2660	AS 20_063 B5 BN 63A 4	72
31	35	1.3	44.73	1010	AS 16_063 B5 BN 63A 4	70
35	31	1.4	40.32	990	AS 16_063 B5 BN 63A 4	70
38	29	2.8	37.31	2530	AS 20_063 B5 BN 63A 4	72
39	28	1.6	36.36	980	AS 16_063 B5 BN 63A 4	70
43	25	1.8	32.78	960	AS 16_063 B5 BN 63A 4	70
44	25	3.2	31.71	2420	AS 20_063 B5 BN 63A 4	72
52	21	2.1	27.14	930	AS 16_063 B5 BN 63A 4	70
67	16	2.8	20.96	890	AS 16_063 B5 BN 63A 4	70
74	15	2.7	18.89	860	AS 16_063 B5 BN 63A 4	70
89	12	3.3	15.64	820	AS 16_063 B5 BN 63A 4	70
112	10	4.1	12.47	780	AS 16_063 B5 BN 63A 4	70
125	9	4.6	11.24	760	AS 16_063 B5 BN 63A 4	70
150	7	4.1	9.31	720	AS 16_063 B5 BN 63A 4	70
189	6	5.2	7.41	680	AS 16_063 B5 BN 63A 4	70
210	5	5.8	6.68	660	AS 16_063 B5 BN 63A 4	70
253	4	7.0	5.53	620	AS 16_063 B5 BN 63A 4	70

0.18 kW

4.5	359	2.2	202.1	9500	AS 45 D_071 B5 BN 71A 6	80
5.0	321	2.5	180.7	9500	AS 45 D_071 B5 BN 71A 6	80
5.5	289	2.8	162.7	9500	AS 45 D_071 B5 BN 71A 6	80
6.0	268	1.3	151.1	5500	AS 30 D_071 B5 BN 71A 6	76
6.0	268	2.0	151.1	7200	AS 35 D_071 B5 BN 71A 6	78
6.1	261	3.1	147.2	9500	AS 45 D_071 B5 BN 71A 6	80
6.7	239	1.5	134.7	5500	AS 30 D_071 B5 BN 71A 6	76
6.7	239	2.2	134.7	7200	AS 35 D_071 B5 BN 71A 6	78
7.3	218	0.9	122.5	3200	AS 25 D_071 B5 BN 71A 6	74
7.4	215	1.6	120.9	5500	AS 30 D_071 B5 BN 71A 6	76
7.4	215	2.5	120.9	7200	AS 35 D_071 B5 BN 71A 6	78
8.2	194	1.0	109.1	3200	AS 25 D_071 B5 BN 71A 6	74
8.8	182	1.0	157.9	3200	AS 25 D_063 B5 BN 63B 4	74
9.1	176	2.0	99.3	5500	AS 30 D_071 B5 BN 71A 6	76
9.1	176	3.0	99.3	7200	AS 35 D_071 B5 BN 71A 6	78
9.6	166	1.1	144.4	3200	AS 25 D_063 B5 BN 63B 4	74
10.0	159	1.3	89.7	3200	AS 25 D_071 B5 BN 71A 6	74
10.9	146	2.4	82.2	5500	AS 30 D_071 B5 BN 71A 6	76
11.0	146	1.4	82	3200	AS 25 D_071 B5 BN 71A 6	74
11.3	141	1.3	122.5	3200	AS 25 D_063 B5 BN 63B 4	74
12.3	130	2.7	73.3	5500	AS 30 D_071 B5 BN 71A 6	76
12.7	126	1.4	109.1	3200	AS 25 D_063 B5 BN 63B 4	74
12.9	124	1.6	69.6	3200	AS 25 D_071 B5 BN 71A 6	74
13.7	117	3.0	65.8	5500	AS 30 D_071 B5 BN 71A 6	76
15.0	107	1.9	60.1	3200	AS 25 D_071 B5 BN 71A 6	74
15.5	103	1.7	89.7	3200	AS 25 D_063 B5 BN 63B 4	74
16.9	94	1.9	82	3200	AS 25 D_063 B5 BN 63B 4	74
17.1	94	1.0	81.4	2800	AS 20 D_063 B5 BN 63B 4	72
20.0	80	2.2	69.6	3200	AS 25 D_063 B5 BN 63B 4	74
20.1	80	1.1	69.2	2730	AS 20 D_063 B5 BN 63B 4	72

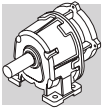

0.18 kW



n_2 min ⁻¹	M_2 Nm	S	i	Rn_2 N			
21.6	74	1.2	64.3	2730	AS 20 D_063 B5	BN 63B 4	72
23.1	69	2.6	60.1	3140	AS 25 D_063 B5	BN 63B 4	74
23.9	67	1.3	58.1	2680	AS 20 D_063 B5	BN 63B 4	72
28.1	58	1.4	49.52	2590	AS 20_063 B5	BN 63B 4	72
31	53	1.5	44.77	2520	AS 20_063 B5	BN 63B 4	72
34	47	1.0	40.32	850	AS 16_063 B5	BN 63B 4	70
37	44	1.8	37.31	2410	AS 20_063 B5	BN 63B 4	72
38	43	1.1	36.36	850	AS 16_063 B5	BN 63B 4	70
42	39	1.2	32.78	840	AS 16_063 B5	BN 63B 4	70
44	37	2.1	31.71	2310	AS 20_063 B5	BN 63B 4	72
49	33	2.4	28.13	2260	AS 20_063 B5	BN 63B 4	72
51	32	1.4	27.14	820	AS 16_063 B5	BN 63B 4	70
55	30	2.7	25.43	2200	AS 20_063 B5	BN 63B 4	72
66	25	3.2	21.19	2100	AS 20_063 B5	BN 63B 4	72
66	25	1.8	20.96	810	AS 16_063 B5	BN 63B 4	70
74	22	1.8	18.89	790	AS 16_063 B5	BN 63B 4	70
89	18	2.2	15.64	760	AS 16_063 B5	BN 63B 4	70
111	15	2.7	12.47	740	AS 16_063 B5	BN 63B 4	70
124	13	3.0	11.24	720	AS 16_063 B5	BN 63B 4	70
149	11	2.7	9.31	690	AS 16_063 B5	BN 63B 4	70
180	9	3.8	15.64	660	AS 16_063 B5	BN 63A 2	70
188	9	3.4	7.41	650	AS 16_063 B5	BN 63B 4	70
208	8	3.8	6.68	640	AS 16_063 B5	BN 63B 4	70
225	7	4.8	12.47	620	AS 16_063 B5	BN 63A 2	70
250	7	5.4	11.24	610	AS 16_063 B5	BN 63A 2	70
251	7	4.6	5.53	600	AS 16_063 B5	BN 63B 4	70
302	5	4.6	9.31	570	AS 16_063 B5	BN 63A 2	70
379	4	5.8	7.41	540	AS 16_063 B5	BN 63A 2	70
421	4	6.4	6.68	520	AS 16_063 B5	BN 63A 2	70
508	3	7.8	5.53	500	AS 16_063 B5	BN 63A 2	70

0.25 kW

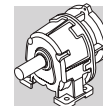
4.5	499	1.6	202.1	9500	AS 45 D_071 B5	BN 71B 6	80
5.0	446	1.8	180.7	9500	AS 45 D_071 B5	BN 71B 6	80
5.5	401	2.0	162.7	9500	AS 45 D_071 B5	BN 71B 6	80
6.0	373	0.9	151.1	5500	AS 30 D_071 B5	BN 71B 6	76
6.0	373	1.4	151.1	7200	AS 35 D_071 B5	BN 71B 6	78
6.1	363	2.2	147.2	9500	AS 45 D_071 B5	BN 71B 6	80
6.7	332	1.1	134.7	5500	AS 30 D_071 B5	BN 71B 6	76
6.7	332	1.6	134.7	7200	AS 35 D_071 B5	BN 71B 6	78
6.8	326	2.2	202.1	9500	AS 45 D_071 B5	BN 71A 4	80
7.4	298	1.2	120.9	5500	AS 30 D_071 B5	BN 71B 6	76
7.4	298	1.8	120.9	7200	AS 35 D_071 B5	BN 71B 6	78
7.6	292	2.5	180.7	9500	AS 45 D_071 B5	BN 71A 4	80
8.5	263	2.7	162.7	9500	AS 45 D_071 B5	BN 71A 4	80
8.5	260	3.1	105.5	9500	AS 45 D_071 B5	BN 71B 6	80
9.1	245	1.4	99.3	5500	AS 30 D_071 B5	BN 71B 6	76
9.1	245	2.2	99.3	7200	AS 35 D_071 B5	BN 71B 6	78
9.1	244	1.3	151.1	5500	AS 30 D_071 B5	BN 71A 4	76
9.1	244	2.0	151.1	7200	AS 35 D_071 B5	BN 71A 4	78
9.3	238	3.0	147.2	9500	AS 45 D_071 B5	BN 71A 4	80
9.5	233	3.4	94.3	9500	AS 45 D_071 B5	BN 71B 6	80
10.0	221	0.9	89.7	3200	AS 25 D_071 B5	BN 71B 6	74
10.2	217	1.5	134.7	5500	AS 30 D_071 B5	BN 71A 4	76
10.2	217	2.2	134.7	7200	AS 35 D_071 B5	BN 71A 4	78
10.9	203	1.7	82.2	5500	AS 30 D_071 B5	BN 71B 6	76
10.9	203	2.6	82.2	7200	AS 35 D_071 B5	BN 71B 6	78



0.25 kW

n_2 min ⁻¹	M_2 Nm	S	i	Rn_2 N			
11.0	202	1.0	82	3180	AS 25 D_071 B5	BN 71B 6	74
11.2	198	0.9	122.5	3140	AS 25 D_071 B5	BN 71A 4	74
11.4	195	1.6	120.9	5500	AS 30 D_071 B5	BN 71A 4	76
11.4	195	2.5	120.9	7200	AS 35 D_071 B5	BN 71A 4	78
12.3	181	1.9	73.3	5500	AS 30 D_071 B5	BN 71B 6	76
12.3	181	2.9	73.3	7200	AS 35 D_071 B5	BN 71B 6	78
12.6	176	1.0	109.1	3200	AS 25 D_071 B5	BN 71A 4	74
12.9	172	1.2	69.6	3120	AS 25 D_071 B5	BN 71B 6	74
13.7	162	2.2	65.8	5500	AS 30 D_071 B5	BN 71B 6	76
13.7	162	3.3	65.8	7200	AS 35 D_071 B5	BN 71B 6	78
13.8	160	2.0	99.3	5500	AS 30 D_071 B5	BN 71A 4	76
13.8	160	3.0	99.3	7200	AS 35 D_071 B5	BN 71A 4	78
15.0	148	1.3	60.1	3150	AS 25 D_071 B5	BN 71B 6	74
15.3	145	1.2	89.7	3120	AS 25 D_071 B5	BN 71A 4	74
16.7	133	2.4	82.2	5500	AS 30 D_071 B5	BN 71A 4	76
16.8	132	1.4	82	3070	AS 25 D_071 B5	BN 71A 4	74
18.8	118	2.7	73.3	5500	AS 30 D_071 B5	BN 71A 4	76
19.8	112	1.6	69.6	2980	AS 25 D_071 B5	BN 71A 4	74
20.9	106	3.0	65.8	5500	AS 30 D_071 B5	BN 71A 4	76
22.9	97	1.9	60.1	2960	AS 25 D_071 B5	BN 71A 4	74
23.7	94	1.0	58.1	2460	AS 20 D_071 B5	BN 71A 4	72
27.8	82	1.0	49.52	2400	AS 20_ 071 B5	BN 71A 4	72
28.0	81	2.0	49.04	2830	AS 25_ 071 B5	BN 71A 4	74
31	74	1.1	44.77	2360	AS 20_ 071 B5	BN 71A 4	72
34	66	2.4	40.29	2710	AS 25_ 071 B5	BN 71A 4	74
37	62	1.3	37.31	2270	AS 20_ 071 B5	BN 71A 4	72
37	61	2.6	36.86	2650	AS 25_ 071 B5	BN 71A 4	74
43	52	1.5	31.71	2190	AS 20_ 071 B5	BN 71A 4	72
44	52	3.1	31.27	2540	AS 25_ 071 B5	BN 71A 4	74
49	46	1.7	28.13	2160	AS 20_ 071 B5	BN 71A 4	72
51	45	1.0	27.14	700	AS 16_ 071 B5	BN 71A 4	70
54	42	1.9	25.43	2110	AS 20_ 071 B5	BN 71A 4	72
65	35	2.3	21.19	2020	AS 20_ 071 B5	BN 71A 4	72
66	35	1.3	20.96	720	AS 16_ 071 B5	BN 71A 4	70
73	31	1.3	18.89	710	AS 16_ 071 B5	BN 71A 4	70
76	30	2.7	18.01	1940	AS 20_ 071 B5	BN 71A 4	72
88	26	1.6	15.64	700	AS 16_ 071 B5	BN 71A 4	70
89	26	2.5	15.48	1880	AS 20_ 071 B5	BN 71A 4	72
98	23	2.8	14	1830	AS 20_ 071 B5	BN 71A 4	72
110	21	1.9	12.47	690	AS 16_ 071 B5	BN 71A 4	70
118	19	3.4	11.67	1730	AS 20_ 071 B5	BN 71A 4	72
122	19	2.2	11.24	670	AS 16_ 071 B5	BN 71A 4	70
148	15	2.0	9.31	650	AS 16_ 071 B5	BN 71A 4	70
180	13	2.8	15.64	620	AS 16_ 063 B5	BN 63B 2	70
185	12	2.5	7.41	620	AS 16_ 071 B5	BN 71A 4	70
206	11	2.7	6.68	610	AS 16_ 071 B5	BN 71A 4	70
225	10	3.5	12.47	600	AS 16_ 063 B5	BN 63B 2	70
249	9	3.3	5.53	580	AS 16_ 071 B5	BN 71A 4	70
250	9	3.9	11.24	580	AS 16_ 063 B5	BN 63B 2	70
302	8	3.3	9.31	550	AS 16_ 063 B5	BN 63B 2	70
379	6	4.2	7.41	530	AS 16_ 063 B5	BN 63B 2	70
421	5	4.6	6.68	510	AS 16_ 063 B5	BN 63B 2	70
508	4	5.6	5.53	480	AS 16_ 063 B5	BN 63B 2	70

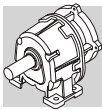

0.37 kW

n_2 min ⁻¹	M_2 Nm	S	i	Rn_2 N			
4.5	730	1.1	202.1	9500	AS 45 D_080 B5	BN 80A 6	80
4.8	687	2.0	190.3	15000	AS 55 D_080 B5	BN 80A 6	82
5.0	653	1.2	180.7	9500	AS 45 D_080 B5	BN 80A 6	80
5.4	608	2.2	168.4	15000	AS 55 D_080 B5	BN 80A 6	82
5.6	587	1.4	162.7	9500	AS 45 D_080 B5	BN 80A 6	80
6.0	546	1.0	151.1	7200	AS 35 D_080 B5	BN 80A 6	78
6.1	542	2.5	150.2	15000	AS 55 D_080 B5	BN 80A 6	82
6.2	531	1.5	147.2	9500	AS 45 D_080 B5	BN 80A 6	80
6.8	487	2.8	134.8	15000	AS 55 D_080 B5	BN 80A 6	82
6.8	486	1.1	134.7	7200	AS 35 D_080 B5	BN 80A 6	78
6.8	485	1.5	202.1	9500	AS 45 D_071 B5	BN 71B 4	80
7.4	443	3.0	122.7	15000	AS 55 D_080 B5	BN 80A 6	82
7.5	437	1.2	120.9	7200	AS 35 D_080 B5	BN 80A 6	78
7.6	434	1.7	180.7	9500	AS 45 D_071 B5	BN 71B 4	80
8.4	392	3.4	108.6	15000	AS 55 D_080 B5	BN 80A 6	82
8.4	390	1.8	162.7	9500	AS 45 D_071 B5	BN 71B 4	80
8.6	381	2.1	105.5	9500	AS 45 D_080 B5	BN 80A 6	80
9.1	363	1.3	151.1	7200	AS 35 D_071 B5	BN 71B 4	78
9.2	359	1.0	99.3	5500	AS 30 D_080 B5	BN 80A 6	76
9.2	359	1.5	99.3	7200	AS 35 D_080 B5	BN 80A 6	78
9.3	353	2.0	147.2	9500	AS 45 D_071 B5	BN 71B 4	80
9.6	341	2.3	94.3	9500	AS 45 D_080 B5	BN 80A 6	80
10.2	323	1.0	134.7	5500	AS 30 D_071 B5	BN 71B 4	76
10.2	323	1.5	134.7	7200	AS 35 D_071 B5	BN 71B 4	78
10.7	306	2.6	84.9	9500	AS 45 D_080 B5	BN 80A 6	80
11.1	297	1.2	82.2	5500	AS 30 D_080 B5	BN 80A 6	76
11.1	297	1.8	82.2	7200	AS 35 D_080 B5	BN 80A 6	78
11.3	290	1.1	120.9	5500	AS 30 D_071 B5	BN 71B 4	76
11.3	290	1.7	120.9	7200	AS 35 D_071 B5	BN 71B 4	78
11.9	277	2.9	76.8	9500	AS 45 D_080 B5	BN 80A 6	80
12.4	265	1.3	73.3	5500	AS 30 D_080 B5	BN 80A 6	76
12.4	265	2.0	73.3	7200	AS 35 D_080 B5	BN 80A 6	78
13.0	253	2.8	105.5	9500	AS 45 D_071 B5	BN 71B 4	80
13.8	238	1.3	99.3	5500	AS 30 D_071 B5	BN 71B 4	76
13.8	238	2.0	99.3	7200	AS 35 D_071 B5	BN 71B 4	78
13.8	238	1.5	65.8	5500	AS 30 D_080 B5	BN 80A 6	76
13.8	238	2.2	65.8	7200	AS 35 D_080 B5	BN 80A 6	78
14.5	226	3.2	94.3	9500	AS 45 D_071 B5	BN 71B 4	80
16.7	197	1.6	82.2	5500	AS 30 D_071 B5	BN 71B 4	76
16.7	197	2.4	82.2	7200	AS 35 D_071 B5	BN 71B 4	78
16.7	197	0.9	82	2610	AS 25 D_071 B5	BN 71B 4	74
18.7	176	1.8	73.3	5480	AS 30 D_071 B5	BN 71B 4	76
18.7	176	2.7	73.3	7200	AS 35 D_071 B5	BN 71B 4	78
19.7	167	1.1	69.6	2580	AS 25 D_071 B5	BN 71B 4	74
20.8	158	2.0	65.8	5340	AS 30 D_071 B5	BN 71B 4	76
20.8	158	3.0	65.8	7200	AS 35 D_071 B5	BN 71B 4	78
22.8	144	1.2	60.1	2630	AS 25 D_071 B5	BN 71B 4	74
25.4	130	2.5	54	5090	AS 30 D_071 B5	BN 71B 4	76
27.9	120	1.3	49.04	2560	AS 25_071 B5	BN 71B 4	74
29.6	111	2.9	46.2	4950	AS 30 D_071 B5	BN 71B 4	76
33	99	3.2	41.2	4800	AS 30 D_071 B5	BN 71B 4	76
34	99	1.6	40.29	2480	AS 25_071 B5	BN 71B 4	74
37	90	1.8	36.86	2440	AS 25_071 B5	BN 71B 4	74
43	78	1.0	31.71	1980	AS 20_071 B5	BN 71B 4	72
44	77	2.1	31.27	2360	AS 25_071 B5	BN 71B 4	74
49	69	1.2	28.13	1980	AS 20_071 B5	BN 71B 4	72
53	63	2.5	25.75	2310	AS 25_071 B5	BN 71B 4	74
54	62	1.3	25.43	1950	AS 20_071 B5	BN 71B 4	72
65	52	1.5	21.19	1880	AS 20_071 B5	BN 71B 4	72
65	52	3.1	21.16	2200	AS 25_071 B5	BN 71B 4	74

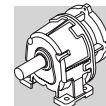

0.37 kW

n_2 min ⁻¹	M_2 Nm	S	i	Rn_2 N	IEC		
71	47	3.4	19.35	2150	AS 25_ 071 B5	BN 71B 4	74
76	44	1.8	18.01	1810	AS 20_ 071 B5	BN 71B 4	72
88	38	1.0	15.64	580	AS 16_ 071 B5	BN 71B 4	70
88	38	1.7	15.48	1780	AS 20_ 071 B5	BN 71B 4	72
98	34	1.9	14	1740	AS 20_ 071 B5	BN 71B 4	72
110	31	1.3	12.47	600	AS 16_ 071 B5	BN 71B 4	70
117	29	2.3	11.67	1660	AS 20_ 071 B5	BN 71B 4	72
122	28	1.5	11.24	590	AS 16_ 071 B5	BN 71B 4	70
138	24	2.7	9.92	1590	AS 20_ 071 B5	BN 71B 4	72
147	23	1.3	9.31	580	AS 16_ 071 B5	BN 71B 4	70
160	21	2.9	8.57	1540	AS 20_ 071 B5	BN 71B 4	72
177	19	3.2	7.75	1500	AS 20_ 071 B5	BN 71B 4	72
180	19	1.9	15.64	560	AS 16_ 071 B5	BN 71A 2	70
181	18	3.0	15.48	1490	AS 20_ 071 B5	BN 71A 2	72
185	18	1.7	7.41	570	AS 16_ 071 B5	BN 71B 4	70
201	17	3.3	14	1450	AS 20_ 071 B5	BN 71A 2	72
205	16	1.8	6.68	560	AS 16_ 071 B5	BN 71B 4	70
225	15	2.3	12.47	550	AS 16_ 071 B5	BN 71A 2	70
248	14	2.2	5.53	540	AS 16_ 071 B5	BN 71B 4	70
250	13	2.6	11.24	540	AS 16_ 071 B5	BN 71A 2	70
302	11	2.2	9.31	520	AS 16_ 071 B5	BN 71A 2	70
379	9	2.8	7.41	500	AS 16_ 071 B5	BN 71A 2	70
421	8	3.1	6.68	490	AS 16_ 071 B5	BN 71A 2	70
508	7	3.8	5.53	460	AS 16_ 071 B5	BN 71A 2	70

0.55 kW

4.8	1010	1.3	190.3	15000	AS 55 D_080 B5	BN 80B 6	82
5.5	894	1.5	168.4	15000	AS 55 D_080 B5	BN 80B 6	82
5.7	864	0.9	162.7	9500	AS 45 D_080 B5	BN 80B 6	80
6.1	798	1.7	150.2	15000	AS 55 D_080 B5	BN 80B 6	82
6.3	781	1.0	147.2	9500	AS 45 D_080 B5	BN 80B 6	80
6.8	716	1.9	134.8	15000	AS 55 D_080 B5	BN 80B 6	82
6.8	715	1.0	202.1	9500	AS 45 D_080 B5	BN 80A 4	80
7.3	674	1.8	190.3	15000	AS 55 D_080 B5	BN 80A 4	82
7.5	652	2.1	122.7	15000	AS 55 D_080 B5	BN 80B 6	82
7.6	640	1.1	180.7	9500	AS 45 D_080 B5	BN 80A 4	80
8.2	596	2.0	168.4	15000	AS 55 D_080 B5	BN 80A 4	82
8.5	577	2.3	108.6	15000	AS 55 D_080 B5	BN 80B 6	82
8.5	576	1.3	162.7	9500	AS 45 D_080 B5	BN 80A 4	80
8.7	560	1.4	105.5	9500	AS 45 D_080 B5	BN 80B 6	80
9.2	532	2.3	150.2	15000	AS 55 D_080 B5	BN 80A 4	82
9.3	527	1.0	99.3	7200	AS 35 D_080 B5	BN 80B 6	78
9.4	521	1.4	147.2	9500	AS 45 D_080 B5	BN 80A 4	80
9.5	514	2.6	96.9	15000	AS 55 D_080 B5	BN 80B 6	82
9.8	501	1.6	94.3	9500	AS 45 D_080 B5	BN 80B 6	80
10.2	477	2.5	134.8	15000	AS 55 D_080 B5	BN 80A 4	82
10.2	477	1.0	134.7	7200	AS 35 D_080 B5	BN 80A 4	78
10.6	462	2.9	87	15000	AS 55 D_080 B5	BN 80B 6	82
10.8	451	1.8	84.9	9500	AS 45 D_080 B5	BN 80B 6	80
11.2	437	1.2	82.2	7200	AS 35 D_080 B5	BN 80B 6	78
11.2	434	2.8	122.7	15000	AS 55 D_080 B5	BN 80A 4	82
11.4	428	1.1	120.9	7200	AS 35 D_080 B5	BN 80A 4	78
12.0	408	2.0	76.8	9500	AS 45 D_080 B5	BN 80B 6	80
12.6	389	1.4	73.3	7200	AS 35 D_080 B5	BN 80B 6	78
12.7	385	3.1	108.6	15000	AS 55 D_080 B5	BN 80A 4	82
13.1	373	1.9	105.5	9500	AS 45 D_080 B5	BN 80A 4	80
13.9	352	0.9	99.3	5000	AS 30 D_080 B5	BN 80A 4	76

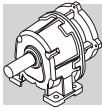

0.55 kW

n_2 min ⁻¹	M_2 Nm	S	i	Rn_2 N			
13.9	352	1.4	99.3	7200	AS 35 D_080 B5	BN 80A 4	78
14.0	349	1.0	65.8	5080	AS 30 D_080 B5	BN 80B 6	76
14.0	349	1.5	65.8	7200	AS 35 D_080 B5	BN 80B 6	78
14.2	343	3.5	96.9	15000	AS 55 D_080 B5	BN 80A 4	82
14.6	334	2.2	94.3	9500	AS 45 D_080 B5	BN 80A 4	80
16.3	300	2.4	84.9	9500	AS 45 D_080 B5	BN 80A 4	80
16.8	291	1.1	82.2	5060	AS 30 D_080 B5	BN 80A 4	76
16.8	291	1.6	82.2	7200	AS 35 D_080 B5	BN 80A 4	78
18.0	272	2.6	76.8	9500	AS 45 D_080 B5	BN 80A 4	80
18.8	259	1.2	73.3	4970	AS 30 D_080 B5	BN 80A 4	76
18.8	259	1.9	73.3	7200	AS 35 D_080 B5	BN 80A 4	78
21.0	233	1.4	65.8	4870	AS 30 D_080 B5	BN 80A 4	76
21.0	233	2.1	65.8	7200	AS 35 D_080 B5	BN 80A 4	78
25.5	191	1.7	54	4680	AS 30 D_080 B5	BN 80A 4	76
25.5	191	2.5	54	7200	AS 35 D_080 B5	BN 80A 4	78
28.1	177	0.9	49.04	2150	AS 25_080 B5	BN 80A 4	74
29.8	164	2.0	46.2	4630	AS 30 D_080 B5	BN 80A 4	76
29.8	164	2.9	46.2	7200	AS 35 D_080 B5	BN 80A 4	78
34	146	2.2	41.2	4510	AS 30 D_080 B5	BN 80A 4	76
34	146	3.3	41.2	7200	AS 35 D_080 B5	BN 80A 4	78
34	146	1.1	40.29	2130	AS 25_080 B5	BN 80A 4	74
37	133	1.2	36.86	2120	AS 25_080 B5	BN 80A 4	74
37	133	2.4	36.82	4400	AS 30_080 B5	BN 80A 4	76
42	119	2.7	32.8	4280	AS 30_080 B5	BN 80A 4	76
44	113	1.4	31.27	2080	AS 25_080 B5	BN 80A 4	74
47	107	3.0	29.45	4160	AS 30_080 B5	BN 80A 4	76
54	93	1.7	25.75	2090	AS 25_080 B5	BN 80A 4	74
65	77	1.0	21.19	1660	AS 20_080 B5	BN 80A 4	72
65	77	2.1	21.16	2020	AS 25_080 B5	BN 80A 4	74
71	70	2.3	19.35	1980	AS 25_080 B5	BN 80A 4	74
77	65	1.2	18.01	1620	AS 20_080 B5	BN 80A 4	72
84	59	2.7	16.42	1920	AS 25_080 B5	BN 80A 4	74
89	56	1.2	15.48	1620	AS 20_080 B5	BN 80A 4	72
99	51	2.6	14.01	1880	AS 25_080 B5	BN 80A 4	74
99	51	1.3	14	1590	AS 20_080 B5	BN 80A 4	72
118	42	1.5	11.67	1540	AS 20_080 B5	BN 80A 4	72
120	42	3.1	11.51	1800	AS 25_080 B5	BN 80A 4	74
131	38	3.4	10.53	1760	AS 25_080 B5	BN 80A 4	74
139	36	1.8	9.92	1480	AS 20_080 B5	BN 80A 4	72
156	32	2.5	18.01	1450	AS 20_071 B5	BN 71B 2	72
161	31	1.9	8.57	1460	AS 20_080 B5	BN 80A 4	72
178	28	2.1	7.75	1420	AS 20_080 B5	BN 80A 4	72
180	28	1.3	15.64	480	AS 16_071 B5	BN 71B 2	70
181	27	2.0	15.48	1420	AS 20_071 B5	BN 71B 2	72
201	25	2.2	14	1380	AS 20_071 B5	BN 71B 2	72
214	23	2.6	6.46	1360	AS 20_080 B5	BN 80A 4	72
225	22	1.6	12.47	490	AS 16_071 B5	BN 71B 2	70
241	21	2.7	11.67	1320	AS 20_071 B5	BN 71B 2	72
250	20	1.8	11.24	480	AS 16_071 B5	BN 71B 2	70
251	20	3.0	5.49	1300	AS 20_080 B5	BN 80A 4	72
283	18	3.1	9.92	1260	AS 20_071 B5	BN 71B 2	72
302	17	1.5	9.31	470	AS 16_071 B5	BN 71B 2	70
328	15	3.3	8.57	1220	AS 20_071 B5	BN 71B 2	72
379	13	1.9	7.41	460	AS 16_071 B5	BN 71B 2	70
421	12	2.1	6.68	450	AS 16_071 B5	BN 71B 2	70
508	10	2.5	5.53	430	AS 16_071 B5	BN 71B 2	70

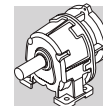

0.75 kW

n_2 min ⁻¹	M_2 Nm	S	i	Rn_2 N	IEC		
4.8	1378	1.0	190.3	15000	AS 55 D_090 B5	BN 90S 6	82
4.9	1358	1.7	187.5	22000	AS 60 D_090 B5	BN 90S 6	84
5.5	1219	1.1	168.4	15000	AS 55 D_090 B5	BN 90S 6	82
5.5	1214	1.9	167.7	22000	AS 60 D_090 B5	BN 90S 6	84
6.1	1093	2.1	151	22000	AS 60 D_090 B5	BN 90S 6	84
6.1	1088	1.2	150.2	15000	AS 55 D_090 B5	BN 90S 6	82
6.7	989	2.3	136.6	22000	AS 60 D_090 B5	BN 90S 6	84
6.8	976	1.4	134.8	15000	AS 55 D_090 B5	BN 90S 6	82
7.4	905	1.3	190.3	15000	AS 55 D_080 B5	BN 80B 4	82
7.5	889	1.5	122.7	15000	AS 55 D_090 B5	BN 90S 6	82
7.6	876	2.6	121	22000	AS 60 D_090 B5	BN 90S 6	84
8.3	801	1.5	168.4	15000	AS 55 D_080 B5	BN 80B 4	82
8.5	787	1.7	108.6	15000	AS 55 D_090 B5	BN 90S 6	82
8.5	783	2.9	108.2	22000	AS 60 D_090 B5	BN 90S 6	84
8.6	774	0.9	162.7	9500	AS 45 D_080 B5	BN 80B 4	80
8.7	764	1.0	105.5	9500	AS 45 D_090 B5	BN 90S 6	80
9.3	715	1.7	150.2	15000	AS 55 D_080 B5	BN 80B 4	82
9.4	705	3.3	97.4	22000	AS 60 D_090 B5	BN 90S 6	84
9.5	702	1.9	96.9	15000	AS 55 D_090 B5	BN 90S 6	82
9.5	700	1.0	147.2	9500	AS 45 D_080 B5	BN 80B 4	80
9.8	683	1.2	94.3	9500	AS 45 D_090 B5	BN 90S 6	80
10.4	641	1.9	134.8	15000	AS 55 D_080 B5	BN 80B 4	82
10.6	630	2.1	87	15000	AS 55 D_090 B5	BN 90S 6	82
10.8	615	1.3	84.9	9500	AS 45 D_090 B5	BN 90S 6	80
11.4	584	2.1	122.7	15000	AS 55 D_080 B5	BN 80B 4	82
11.9	561	2.4	77.5	15000	AS 55 D_090 B5	BN 90S 6	82
12.0	556	1.4	76.8	9500	AS 45 D_090 B5	BN 90S 6	80
12.6	530	1.0	73.3	7200	AS 35 D_090 B5	BN 90S 6	78
12.9	517	2.3	108.6	15000	AS 55 D_080 B5	BN 80B 4	82
13.3	502	1.4	105.5	9500	AS 45 D_080 B5	BN 80B 4	80
13.4	497	2.7	68.6	15000	AS 55 D_090 B5	BN 90S 6	82
14.0	476	1.1	65.8	7200	AS 35 D_090 B5	BN 90S 6	78
14.1	473	1.0	99.3	7200	AS 35 D_080 B5	BN 80B 4	78
14.4	461	2.6	96.9	15000	AS 55 D_080 B5	BN 80B 4	82
14.7	454	1.8	62.7	9500	AS 45 D_090 B5	BN 90S 6	80
14.8	449	1.6	94.3	9500	AS 45 D_080 B5	BN 80B 4	80
15.0	443	3.0	61.2	15000	AS 55 D_090 B5	BN 90S 6	82
16.1	414	2.9	87	15000	AS 55 D_080 B5	BN 80B 4	82
16.5	404	1.8	84.9	9500	AS 45 D_080 B5	BN 80B 4	80
17.0	391	1.2	82.2	7200	AS 35 D_080 B5	BN 80B 4	78
18.2	365	2.0	76.8	9500	AS 45 D_080 B5	BN 80B 4	80
19.1	349	0.9	73.3	4400	AS 30 D_080 B5	BN 80B 4	76
19.1	349	1.4	73.3	7200	AS 35 D_080 B5	BN 80B 4	78
21.3	313	1.0	65.8	4360	AS 30 D_080 B5	BN 80B 4	76
21.3	313	1.5	65.8	7200	AS 35 D_080 B5	BN 80B 4	78
25.9	257	1.2	54	4240	AS 30 D_080 B5	BN 80B 4	76
25.9	257	1.9	54	7200	AS 35 D_080 B5	BN 80B 4	78
30	220	1.5	46.2	4270	AS 30 D_080 B5	BN 80B 4	76
30	220	2.2	46.2	7200	AS 35 D_080 B5	BN 80B 4	78
34	196	1.6	41.2	4180	AS 30 D_080 B5	BN 80B 4	76
34	196	2.4	41.2	7200	AS 35 D_080 B5	BN 80B 4	78
38	179	1.8	36.82	4100	AS 30_080 B5	BN 80B 4	76
38	179	2.7	36.82	7200	AS 35_080 B5	BN 80B 4	78
43	159	2.0	32.8	4010	AS 30_080 B5	BN 80B 4	76
43	159	3.0	32.8	7200	AS 35_080 B5	BN 80B 4	78
45	152	1.1	31.27	1780	AS 25_080 B5	BN 80B 4	74
48	143	2.2	29.45	3920	AS 30_080 B5	BN 80B 4	76
48	143	3.4	29.45	7200	AS 35_080 B5	BN 80B 4	78
54	125	1.3	25.75	1850	AS 25_080 B5	BN 80B 4	74

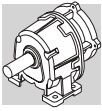

0.75 kW



n_2 min ⁻¹	M_2 Nm	S	i	Rn_2 N	IEC	
58	118	2.7	24.19	3740	AS 30_ 080 B5 BN 80B 4	76
66	103	1.6	21.16	1820	AS 25_ 080 B5 BN 80B 4	74
72	94	1.7	19.35	1800	AS 25_ 080 B5 BN 80B 4	74
73	93	2.8	19.21	3600	AS 30_ 080 B5 BN 80B 4	76
78	88	0.9	18.01	1420	AS 20_ 080 B5 BN 80B 4	72
82	83	3.1	17.11	3500	AS 30_ 080 B5 BN 80B 4	76
85	80	2.0	16.42	1750	AS 25_ 080 B5 BN 80B 4	74
91	75	3.5	15.37	3400	AS 30_ 080 B5 BN 80B 4	76
100	68	1.9	14.01	1750	AS 25_ 080 B5 BN 80B 4	74
100	68	1.0	14	1440	AS 20_ 080 B5 BN 80B 4	72
120	57	1.1	11.67	1410	AS 20_ 080 B5 BN 80B 4	72
122	56	2.3	11.51	1680	AS 25_ 080 B5 BN 80B 4	74
133	51	2.5	10.53	1650	AS 25_ 080 B5 BN 80B 4	74
141	48	1.3	9.92	1370	AS 20_ 080 B5 BN 80B 4	72
155	44	1.8	18.01	1350	AS 20_ 080 B5 BN 80A 2	72
157	43	3.0	8.93	1590	AS 25_ 080 B5 BN 80B 4	74
163	42	1.4	8.57	1360	AS 20_ 080 B5 BN 80B 4	72
178	38	3.1	7.88	1570	AS 25_ 080 B5 BN 80B 4	74
181	38	1.6	7.75	1330	AS 20_ 080 B5 BN 80B 4	72
181	38	1.5	15.48	1340	AS 20_ 080 B5 BN 80A 2	72
200	34	3.2	14.01	1530	AS 25_ 080 B5 BN 80A 2	74
200	34	1.6	14	1310	AS 20_ 080 B5 BN 80A 2	72
217	31	1.9	6.46	1280	AS 20_ 080 B5 BN 80B 4	72
240	28	1.9	11.67	1260	AS 20_ 080 B5 BN 80A 2	72
255	27	2.2	5.49	1240	AS 20_ 080 B5 BN 80B 4	72
282	24	2.3	9.92	1210	AS 20_ 080 B5 BN 80A 2	72
327	21	2.4	8.57	1180	AS 20_ 080 B5 BN 80A 2	72
361	19	2.7	7.75	1150	AS 20_ 080 B5 BN 80A 2	72
434	16	3.2	6.46	1100	AS 20_ 080 B5 BN 80A 2	72

1.1 kW

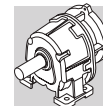
4.9	1992	1.2	187.5	22000	AS 60 D_090 B5 BN 90L 6	84
5.5	1781	1.3	167.7	22000	AS 60 D_090 B5 BN 90L 6	84
6.1	1603	1.4	151	22000	AS 60 D_090 B5 BN 90L 6	84
6.7	1450	1.6	136.6	22000	AS 60 D_090 B5 BN 90L 6	84
6.8	1432	0.9	134.8	15000	AS 55 D_090 B5 BN 90L 6	82
7.4	1328	0.9	190.3	15000	AS 55 D_090 B5 BN 90S 4	82
7.5	1309	1.6	187.5	22000	AS 60 D_090 B5 BN 90S 4	84
7.5	1303	1.0	122.7	15000	AS 55 D_090 B5 BN 90L 6	82
7.6	1285	1.8	121	22000	AS 60 D_090 B5 BN 90L 6	84
8.3	1175	1.0	168.4	15000	AS 55 D_090 B5 BN 90S 4	82
8.3	1170	1.8	167.7	22000	AS 60 D_090 B5 BN 90S 4	84
8.5	1154	1.2	108.6	15000	AS 55 D_090 B5 BN 90L 6	82
8.5	1149	2.0	108.2	22000	AS 60 D_090 B5 BN 90L 6	84
9.3	1053	2.0	151	22000	AS 60 D_090 B5 BN 90S 4	84
9.3	1048	1.1	150.2	15000	AS 55 D_090 B5 BN 90S 4	82
9.4	1034	2.2	97.4	22000	AS 60 D_090 B5 BN 90L 6	84
9.5	1029	1.3	96.9	15000	AS 55 D_090 B5 BN 90L 6	82
10.3	953	2.2	136.6	22000	AS 60 D_090 B5 BN 90S 4	84
10.4	941	1.3	134.8	15000	AS 55 D_090 B5 BN 90S 4	82
10.4	936	2.5	88.1	22000	AS 60 D_090 B5 BN 90L 6	84
10.6	923	1.5	87	15000	AS 55 D_090 B5 BN 90L 6	82
11.4	857	1.4	122.7	15000	AS 55 D_090 B5 BN 90S 4	82
11.6	844	2.5	121	22000	AS 60 D_090 B5 BN 90S 4	84
11.9	823	1.6	77.5	15000	AS 55 D_090 B5 BN 90L 6	82
12.0	815	1.0	76.8	9500	AS 45 D_090 B5 BN 90L 6	80



1.1 kW

n_2 min ⁻¹	M_2 Nm	S	i	Rn_2 N			
12.9	758	1.6	108.6	15000	AS 55 D_090 B5	BN 90S 4	82
12.9	755	2.8	108.2	22000	AS 60 D_090 B5	BN 90S 4	84
13.3	736	1.0	105.5	9500	AS 45 D_090 B5	BN 90S 4	80
13.4	729	1.9	68.6	15000	AS 55 D_090 B5	BN 90L 6	82
14.4	680	3.1	97.4	22000	AS 60 D_090 B5	BN 90S 4	84
14.4	676	1.8	96.9	15000	AS 55 D_090 B5	BN 90S 4	82
14.7	666	1.2	62.7	9500	AS 45 D_090 B5	BN 90L 6	80
14.8	658	1.1	94.3	9500	AS 45 D_090 B5	BN 90S 4	80
15.0	650	2.1	61.2	15000	AS 55 D_090 B5	BN 90L 6	82
15.9	615	3.4	88.1	22000	AS 60 D_090 B5	BN 90S 4	84
16.1	607	2.0	87	15000	AS 55 D_090 B5	BN 90S 4	82
16.5	592	1.2	84.9	9500	AS 45 D_090 B5	BN 90S 4	80
18.1	541	2.2	77.5	15000	AS 55 D_090 B5	BN 90S 4	82
18.2	536	1.3	76.8	9500	AS 45 D_090 B5	BN 90S 4	80
19.1	511	0.9	73.3	7200	AS 35 D_090 B5	BN 90S 4	78
20.4	479	2.5	68.6	15000	AS 55 D_090 B5	BN 90S 4	82
21.3	459	1.0	65.8	7200	AS 35 D_090 B5	BN 90S 4	78
22.3	438	1.6	62.7	9500	AS 45 D_090 B5	BN 90S 4	80
22.9	427	2.8	61.2	15000	AS 55 D_090 B5	BN 90S 4	82
25.0	392	1.8	56.1	9500	AS 45 D_090 B5	BN 90S 4	80
25.5	383	3.1	54.9	15000	AS 55 D_090 B5	BN 90S 4	82
25.9	377	1.3	54	7200	AS 35 D_090 B5	BN 90S 4	78
27.7	352	2.0	50.5	9500	AS 45 D_090 B5	BN 90S 4	80
30	323	1.0	46.2	3670	AS 30 D_090 B5	BN 90S 4	76
30	323	1.5	46.2	7200	AS 35 D_090 B5	BN 90S 4	78
31	319	2.3	45.7	9500	AS 45 D_090 B5	BN 90S 4	80
33	298	2.4	42.7	9500	AS 45 D_090 B5	BN 90S 4	80
34	287	1.1	41.2	3640	AS 30 D_090 B5	BN 90S 4	76
34	287	1.7	41.2	7200	AS 35 D_090 B5	BN 90S 4	78
37	266	2.7	38.2	9500	AS 45 D_090 B5	BN 90S 4	80
38	262	1.2	36.82	3610	AS 30_090 B5	BN 90S 4	76
38	262	1.8	36.82	7200	AS 35_090 B5	BN 90S 4	78
41	240	3.0	34.4	9500	AS 45 D_090 B5	BN 90S 4	80
43	234	1.4	32.8	3560	AS 30_090 B5	BN 90S 4	76
43	234	2.1	32.8	7200	AS 35_090 B5	BN 90S 4	78
45	217	3.3	31.1	9500	AS 45 D_090 B5	BN 90S 4	80
48	210	1.5	29.45	3510	AS 30_090 B5	BN 90S 4	76
48	210	2.3	29.45	7200	AS 35_090 B5	BN 90S 4	78
58	172	1.9	24.19	3400	AS 30_090 B5	BN 90S 4	76
58	172	2.8	24.19	7200	AS 35_090 B5	BN 90S 4	78
66	151	1.1	21.16	1470	AS 25_090 B5	BN 90S 4	74
72	138	1.2	19.35	1480	AS 25_090 B5	BN 90S 4	74
73	137	1.9	19.21	3350	AS 30_090 B5	BN 90S 4	76
73	137	2.9	19.21	7200	AS 35_090 B5	BN 90S 4	78
82	122	2.1	17.11	3260	AS 30_090 B5	BN 90S 4	76
82	122	3.3	17.11	7200	AS 35_090 B5	BN 90S 4	78
85	117	1.4	16.42	1470	AS 25_090 B5	BN 90S 4	74
91	110	2.4	15.37	3190	AS 30_090 B5	BN 90S 4	76
100	100	1.3	14.01	1530	AS 25_090 B5	BN 90S 4	74
111	90	2.9	12.62	3040	AS 30_090 B5	BN 90S 4	76
122	82	1.6	11.51	1500	AS 25_090 B5	BN 90S 4	74
123	81	3.2	11.43	3010	AS 30_090 B5	BN 90S 4	76
133	75	1.7	10.53	1480	AS 25_090 B5	BN 90S 4	74
141	71	0.9	9.92	1170	AS 20_090 B5	BN 90S 4	72
155	64	1.2	18.01	1170	AS 20_080 B5	BN 80B 2	72
157	64	2.0	8.93	1440	AS 25_090 B5	BN 90S 4	74
163	61	1.0	8.57	1200	AS 20_090 B5	BN 90S 4	72
171	59	2.7	16.42	1430	AS 25_080 B5	BN 80B 2	74
178	56	2.1	7.88	1440	AS 25_090 B5	BN 90S 4	74
181	55	1.1	7.75	1190	AS 20_090 B5	BN 90S 4	72

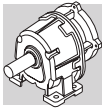

1.1 kW



n_2 min ⁻¹	M_2 Nm	S	i	Rn_2 N	IEC		
181	55	1.1	7.75	1190	AS 20_ 090 B5	BN 90S 4	72
181	55	1.0	15.48	1190	AS 20_ 080 B5	BN 80B 2	72
200	50	2.2	14.01	1420	AS 25_ 080 B5	BN 80B 2	74
200	50	1.1	14	1180	AS 20_ 080 B5	BN 80B 2	72
216	46	2.6	6.47	1390	AS 25_ 090 B5	BN 90S 4	74
217	46	1.3	6.46	1160	AS 20_ 090 B5	BN 90S 4	72
236	42	2.8	5.92	1360	AS 25_ 090 B5	BN 90S 4	74
240	42	1.3	11.67	1140	AS 20_ 080 B5	BN 80B 2	72
243	41	2.7	11.51	1360	AS 25_ 080 B5	BN 80B 2	74
255	39	1.5	5.49	1130	AS 20_ 090 B5	BN 90S 4	72
266	38	2.9	10.53	1330	AS 25_ 080 B5	BN 80B 2	74
279	36	3.4	5.02	1320	AS 25_ 090 B5	BN 90S 4	74
282	35	1.6	9.92	1110	AS 20_ 080 B5	BN 80B 2	72
313	32	3.5	8.93	1280	AS 25_ 080 B5	BN 80B 2	74
327	31	1.6	8.57	1100	AS 20_ 080 B5	BN 80B 2	72
361	28	1.8	7.75	1080	AS 20_ 080 B5	BN 80B 2	72
434	23	2.2	6.46	1030	AS 20_ 080 B5	BN 80B 2	72
510	20	2.6	5.49	990	AS 20_ 080 B5	BN 80B 2	72

1.5 kW

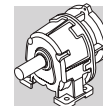
5.4	2455	2.8	173.2	42000	AS 90 D_ 100 B5	BN 100LA 6	88
5.5	2443	1.7	172.3	31000	AS 80 D_ 100 B5	BN 100LA 6	86
5.6	2377	1.0	167.7	22000	AS 60 D_ 100 B5	BN 100LA 6	84
6.1	2195	3.1	154.9	42000	AS 90 D_ 100 B5	BN 100LA 6	88
6.1	2184	1.9	154.1	31000	AS 80 D_ 100 B5	BN 100LA 6	86
6.2	2139	1.1	151	22000	AS 60 D_ 100 B5	BN 100LA 6	84
6.7	1976	3.4	139.4	42000	AS 90 D_ 100 B5	BN 100LA 6	88
6.8	1966	2.1	138.7	31000	AS 80 D_ 100 B5	BN 100LA 6	86
6.9	1936	1.2	136.6	22000	AS 60 D_ 100 B5	BN 100LA 6	84
7.5	1779	2.4	125.5	31000	AS 80 D_ 100 B5	BN 100LA 6	86
7.5	1772	1.2	187.5	22000	AS 60 D_ 090 B5	BN 90LA 4	84
7.8	1715	1.3	121	22000	AS 60 D_ 100 B5	BN 100LA 6	84
8.4	1585	1.3	167.7	22000	AS 60 D_ 090 B5	BN 90LA 4	84
8.7	1533	1.5	108.2	22000	AS 60 D_ 100 B5	BN 100LA 6	84
8.8	1509	2.8	106.5	31000	AS 80 D_ 100 B5	BN 100LA 6	86
9.3	1426	1.5	151	22000	AS 60 D_ 090 B5	BN 90LA 4	84
9.7	1380	1.7	97.4	22000	AS 60 D_ 100 B5	BN 100LA 6	84
9.7	1373	1.0	96.9	15000	AS 55 D_ 100 B5	BN 100LA 6	82
9.9	1349	3.1	95.2	31000	AS 80 D_ 100 B5	BN 100LA 6	86
10.3	1290	1.6	136.6	22000	AS 60 D_ 090 B5	BN 90LA 4	84
10.5	1274	0.9	134.8	15000	AS 55 D_ 090 B5	BN 90LA 4	82
10.7	1249	1.8	88.1	22000	AS 60 D_ 100 B5	BN 100LA 6	84
10.8	1232	1.1	87	15000	AS 55 D_ 100 B5	BN 100LA 6	82
11.0	1214	3.5	85.7	31000	AS 80 D_ 100 B5	BN 100LA 6	86
11.5	1160	1.0	122.7	15000	AS 55 D_ 090 B5	BN 90LA 4	82
11.7	1143	1.8	121	22000	AS 60 D_ 090 B5	BN 90LA 4	84
12.1	1099	1.2	77.5	15000	AS 55 D_ 100 B5	BN 100LA 6	82
12.3	1083	2.1	76.4	22000	AS 60 D_ 100 B5	BN 100LA 6	84
13.0	1027	1.2	108.6	15000	AS 55 D_ 090 B5	BN 90LA 4	82
13.0	1022	2.1	108.2	22000	AS 60 D_ 090 B5	BN 90LA 4	84
13.7	972	1.4	68.6	15000	AS 55 D_ 100 B5	BN 100LA 6	82
13.8	968	2.4	68.3	22000	AS 60 D_ 100 B5	BN 100LA 6	84
14.5	920	2.3	97.4	22000	AS 60 D_ 090 B5	BN 90LA 4	84
14.6	916	1.3	96.9	15000	AS 55 D_ 090 B5	BN 90LA 4	82
16.0	832	2.5	88.1	22000	AS 60 D_ 090 B5	BN 90LA 4	84
16.2	822	1.5	87	15000	AS 55 D_ 090 B5	BN 90LA 4	82
18.2	732	1.6	77.5	15000	AS 55 D_ 090 B5	BN 90LA 4	82



1.5 kW

n_2 min ⁻¹	M_2 Nm	S	i	Rn_2 N			
18.4	726	1.0	76.8	9500	AS 45 D_090 B5	BN 90LA 4	80
20.5	648	1.9	68.6	15000	AS 55 D_090 B5	BN 90LA 4	82
22.5	593	1.2	62.7	9500	AS 45 D_090 B5	BN 90LA 4	80
23.0	578	2.1	61.2	15000	AS 55 D_090 B5	BN 90LA 4	82
25.7	519	2.3	54.9	15000	AS 55 D_090 B5	BN 90LA 4	82
26.1	511	0.9	54	7200	AS 35 D_090 B5	BN 90LA 4	78
27.9	477	1.5	50.5	9500	AS 45 D_090 B5	BN 90LA 4	80
30	437	1.1	46.2	7200	AS 35 D_090 B5	BN 90LA 4	78
31	432	1.7	45.7	9500	AS 45 D_090 B5	BN 90LA 4	80
33	403	1.8	42.7	9500	AS 45 D_090 B5	BN 90LA 4	80
34	398	3.0	42.1	15000	AS 55 D_090 B5	BN 90LA 4	82
34	389	1.2	41.2	7200	AS 35 D_090 B5	BN 90LA 4	78
37	361	2.0	38.2	9500	AS 45 D_090 B5	BN 90LA 4	80
38	352	3.4	37.2	15000	AS 55 D_090 B5	BN 90LA 4	82
38	355	0.9	36.82	3060	AS 30_090 B5	BN 90LA 4	76
38	355	1.4	36.82	7200	AS 35_090 B5	BN 90LA 4	78
41	325	2.2	34.4	9500	AS 45 D_090 B5	BN 90LA 4	80
43	317	1.0	32.8	3060	AS 30_090 B5	BN 90LA 4	76
43	317	1.5	32.8	7200	AS 35_090 B5	BN 90LA 4	78
45	294	2.5	31.1	9500	AS 45 D_090 B5	BN 90LA 4	80
48	284	1.1	29.45	3050	AS 30_090 B5	BN 90LA 4	76
48	284	1.7	29.45	7200	AS 35_090 B5	BN 90LA 4	78
51	265	2.7	27.45	9500	AS 45_090 B5	BN 90LA 4	80
57	237	3.0	24.55	9500	AS 45_090 B5	BN 90LA 4	80
58	234	1.4	24.19	3000	AS 30_090 B5	BN 90LA 4	76
58	234	2.1	24.19	7200	AS 35_090 B5	BN 90LA 4	78
64	213	3.4	22.09	9500	AS 45_090 B5	BN 90LA 4	80
73	185	1.4	19.21	3050	AS 30_090 B5	BN 90LA 4	76
73	185	2.2	19.21	7200	AS 35_090 B5	BN 90LA 4	78
82	165	1.6	17.11	3000	AS 30_090 B5	BN 90LA 4	76
82	165	2.4	17.11	7200	AS 35_090 B5	BN 90LA 4	78
86	158	1.0	16.42	1160	AS 25_090 B5	BN 90LA 4	74
92	148	1.8	15.37	2940	AS 30_090 B5	BN 90LA 4	76
92	148	2.7	15.37	7200	AS 35_090 B5	BN 90LA 4	78
101	135	1.0	14.01	1270	AS 25_090 B5	BN 90LA 4	74
112	122	2.1	12.62	2830	AS 30_090 B5	BN 90LA 4	76
112	122	3.3	12.62	7200	AS 35_090 B5	BN 90LA 4	78
122	111	1.2	11.51	1280	AS 25_090 B5	BN 90LA 4	74
123	110	2.4	11.43	2830	AS 30_090 B5	BN 90LA 4	76
134	102	1.3	10.53	1280	AS 25_090 B5	BN 90LA 4	74
138	98	2.6	10.18	2760	AS 30_090 B5	BN 90LA 4	76
154	88	2.9	9.14	2700	AS 30_090 B5	BN 90LA 4	76
155	88	0.9	18.01	970	AS 20_090 B5	BN 90SA 2	72
158	86	1.5	8.93	1270	AS 25_090 B5	BN 90LA 4	74
164	83	2.9	17.11	2670	AS 30_090 B5	BN 90SA 2	76
171	80	2.0	16.42	1270	AS 25_090 B5	BN 90SA 2	74
179	76	1.6	7.88	1300	AS 25_090 B5	BN 90LA 4	74
181	75	3.1	7.78	2620	AS 30_090 B5	BN 90LA 4	76
182	75	3.2	15.37	2600	AS 30_090 B5	BN 90SA 2	76
188	72	3.2	7.51	2570	AS 30_090 B5	BN 90LA 4	76
200	68	1.6	14.01	1290	AS 25_090 B5	BN 90SA 2	74
203	67	3.4	6.93	2550	AS 30_090 B5	BN 90LA 4	76
218	62	1.9	6.47	1270	AS 25_090 B5	BN 90LA 4	74
218	62	1.0	6.46	1020	AS 20_090 B5	BN 90LA 4	72
238	57	2.1	5.92	1250	AS 25_090 B5	BN 90LA 4	74
240	57	1.0	11.67	1020	AS 20_090 B5	BN 90SA 2	72
243	56	2.0	11.51	1250	AS 25_090 B5	BN 90SA 2	74
257	53	1.1	5.49	1000	AS 20_090 B5	BN 90LA 4	72
266	51	2.1	10.53	1230	AS 25_090 B5	BN 90SA 2	74
281	48	2.5	5.02	1220	AS 25_090 B5	BN 90LA 4	74

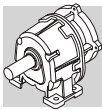

1.5 kW



n_2 min ⁻¹	M_2 Nm	S	i	Rn_2 N	IEC		
282	48	1.1	9.92	1000	AS 20_ 090 B5	BN 90SA 2	72
313	43	2.5	8.93	1200	AS 25_ 090 B5	BN 90SA 2	74
327	42	1.2	8.57	1010	AS 20_ 090 B5	BN 90SA 2	72
355	38	2.6	7.88	1190	AS 25_ 090 B5	BN 90SA 2	74
361	38	1.3	7.75	990	AS 20_ 090 B5	BN 90SA 2	72
433	31	3.2	6.47	1140	AS 25_ 090 B5	BN 90SA 2	74
434	31	1.6	6.46	960	AS 20_ 090 B5	BN 90SA 2	72
473	29	3.5	5.92	1120	AS 25_ 090 B5	BN 90SA 2	74
510	27	1.9	5.49	930	AS 20_ 090 B5	BN 90SA 2	72

2.2 kW

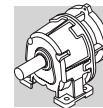
5.4	3639	1.9	173.2	42000	AS 90 D_ 112 B5	BN 112M 6	88
5.4	3621	1.2	172.3	31000	AS 80 D_ 112 B5	BN 112M 6	86
6.0	3254	2.1	154.9	42000	AS 90 D_ 112 B5	BN 112M 6	88
6.0	3238	1.3	154.1	31000	AS 80 D_ 112 B5	BN 112M 6	86
6.7	2929	2.3	139.4	42000	AS 90 D_ 112 B5	BN 112M 6	88
6.7	2915	1.4	138.7	31000	AS 80 D_ 112 B5	BN 112M 6	86
7.4	2650	2.6	126.1	42000	AS 90 D_ 112 B5	BN 112M 6	88
7.4	2637	1.6	125.5	31000	AS 80 D_ 112 B5	BN 112M 6	86
7.7	2542	0.9	121	22000	AS 60 D_ 112 B5	BN 112M 6	84
8.1	2400	2.6	173.2	42000	AS 90 D_ 100 B5	BN 100LA 4	88
8.2	2388	1.6	172.3	31000	AS 80 D_ 100 B5	BN 100LA 4	86
8.4	2324	0.9	167.7	22000	AS 60 D_ 100 B5	BN 100LA 4	84
8.6	2273	1.0	108.2	22000	AS 60 D_ 112 B5	BN 112M 6	84
8.7	2237	1.9	106.5	31000	AS 80 D_ 112 B5	BN 112M 6	86
8.7	2237	3.0	106.5	42000	AS 90 D_ 112 B5	BN 112M 6	88
9.1	2146	2.9	154.9	42000	AS 90 D_ 100 B5	BN 100LA 4	88
9.1	2136	1.8	154.1	31000	AS 80 D_ 100 B5	BN 100LA 4	86
9.3	2092	1.0	151	22000	AS 60 D_ 100 B5	BN 100LA 4	84
9.6	2046	1.1	97.4	22000	AS 60 D_ 112 B5	BN 112M 6	84
9.8	2000	2.1	95.2	31000	AS 80 D_ 112 B5	BN 112M 6	86
9.8	2000	3.4	95.2	42000	AS 90 D_ 112 B5	BN 112M 6	88
10.1	1932	3.2	139.4	42000	AS 90 D_ 100 B5	BN 100LA 4	88
10.2	1922	2.0	138.7	31000	AS 80 D_ 100 B5	BN 100LA 4	86
10.3	1893	1.1	136.6	22000	AS 60 D_ 100 B5	BN 100LA 4	84
10.6	1851	1.2	88.1	22000	AS 60 D_ 112 B5	BN 112M 6	84
10.9	1800	2.3	85.7	31000	AS 80 D_ 112 B5	BN 112M 6	86
11.2	1739	2.2	125.5	31000	AS 80 D_ 100 B5	BN 100LA 4	86
11.7	1677	1.3	121	22000	AS 60 D_ 100 B5	BN 100LA 4	84
12.0	1629	2.6	77.5	31000	AS 80 D_ 112 B5	BN 112M 6	86
12.2	1605	1.4	76.4	22000	AS 60 D_ 112 B5	BN 112M 6	84
13.0	1499	1.4	108.2	22000	AS 60 D_ 100 B5	BN 100LA 4	84
13.2	1475	2.6	106.5	31000	AS 80 D_ 100 B5	BN 100LA 4	86
13.6	1442	0.9	68.6	15000	AS 55 D_ 112 B5	BN 112M 6	82
13.6	1436	1.6	68.3	22000	AS 60 D_ 112 B5	BN 112M 6	84
14.5	1349	1.6	97.4	22000	AS 60 D_ 100 B5	BN 100LA 4	84
14.8	1319	2.9	95.2	31000	AS 80 D_ 100 B5	BN 100LA 4	86
16.0	1221	1.7	88.1	22000	AS 60 D_ 100 B5	BN 100LA 4	84
16.2	1205	1.0	87	15000	AS 55 D_ 100 B5	BN 100LA 4	82
16.5	1187	3.2	85.7	31000	AS 80 D_ 100 B5	BN 100LA 4	86
18.2	1074	1.1	77.5	15000	AS 55 D_ 100 B5	BN 100LA 4	82
18.5	1059	2.0	76.4	22000	AS 60 D_ 100 B5	BN 100LA 4	84
20.5	951	1.3	68.6	15000	AS 55 D_ 100 B5	BN 100LA 4	82
20.6	947	2.2	68.3	21500	AS 60 D_ 100 B5	BN 100LA 4	84
22.9	852	2.5	61.5	20900	AS 60 D_ 100 B5	BN 100LA 4	84
23.0	848	1.4	61.2	15000	AS 55 D_ 100 B5	BN 100LA 4	82
25.1	777	0.9	56.1	9500	AS 45 D_ 100 B5	BN 100LA 4	80



2.2 kW

n_2 min ⁻¹	M_2 Nm	S	i	Rn_2 N		
25.3	771	2.7	55.6	20400	AS 60 D_100 B5 BN 100LA 4	84
25.7	761	1.6	54.9	15000	AS 55 D_100 B5 BN 100LA 4	82
27.9	700	1.0	50.5	9500	AS 45 D_100 B5 BN 100LA 4	80
31	633	1.1	45.7	9500	AS 45 D_100 B5 BN 100LA 4	80
33	592	1.2	42.7	9500	AS 45 D_100 B5 BN 100LA 4	80
34	583	2.1	42.1	15000	AS 55 D_100 B5 BN 100LA 4	82
37	529	1.4	38.2	9500	AS 45 D_100 B5 BN 100LA 4	80
38	516	2.3	37.2	15000	AS 55 D_100 B5 BN 100LA 4	82
38	521	0.9	36.82	7200	AS 35_100 B5 BN 100LA 4	78
41	476	1.5	34.4	9500	AS 45 D_100 B5 BN 100LA 4	80
42	460	2.6	33.2	15000	AS 55 D_100 B5 BN 100LA 4	82
43	464	1.0	32.8	7200	AS 35_100 B5 BN 100LA 4	78
45	431	1.7	31.1	9500	AS 45 D_100 B5 BN 100LA 4	80
47	413	2.9	29.8	15000	AS 55 D_100 B5 BN 100LA 4	82
48	417	1.2	29.45	7200	AS 35_100 B5 BN 100LA 4	78
51	389	1.9	27.45	9500	AS 45_100 B5 BN 100LA 4	80
55	366	3.3	25.84	15000	AS 55_100 B5 BN 100LA 4	82
57	347	2.1	24.55	9500	AS 45_100 B5 BN 100LA 4	80
58	342	0.9	24.19	2320	AS 30_100 B5 BN 100LA 4	76
58	342	1.4	24.19	7200	AS 35_100 B5 BN 100LA 4	78
64	313	2.3	22.09	9410	AS 45_100 B5 BN 100LA 4	80
71	283	2.5	19.99	9210	AS 45_100 B5 BN 100LA 4	80
73	272	1.0	19.21	2540	AS 30_100 B5 BN 100LA 4	76
73	272	1.5	19.21	7200	AS 35_100 B5 BN 100LA 4	78
80	251	2.6	17.7	9050	AS 45_100 B5 BN 100LA 4	80
82	242	1.1	17.11	2540	AS 30_100 B5 BN 100LA 4	76
82	242	1.7	17.11	7200	AS 35_100 B5 BN 100LA 4	78
89	224	2.9	15.83	8820	AS 45_100 B5 BN 100LA 4	80
92	218	1.2	15.37	2520	AS 30_100 B5 BN 100LA 4	76
92	218	1.8	15.37	7200	AS 35_100 B5 BN 100LA 4	78
99	202	3.2	14.25	8600	AS 45_100 B5 BN 100LA 4	80
112	179	1.5	12.62	2480	AS 30_100 B5 BN 100LA 4	76
112	179	2.2	12.62	7200	AS 35_100 B5 BN 100LA 4	78
123	162	1.6	11.43	2530	AS 30_100 B5 BN 100LA 4	76
123	162	2.5	11.43	7200	AS 35_100 B5 BN 100LA 4	78
138	144	1.8	10.18	2490	AS 30_100 B5 BN 100LA 4	76
138	144	2.8	10.18	7110	AS 35_100 B5 BN 100LA 4	78
154	129	2.0	9.14	2450	AS 30_100 B5 BN 100LA 4	76
154	129	3.1	9.14	6920	AS 35_100 B5 BN 100LA 4	78
164	122	2.0	17.11	2440	AS 30_090 B5 BN 90L 2	76
164	122	3.0	17.11	6830	AS 35_090 B5 BN 90L 2	78
171	117	1.4	16.42	990	AS 25_090 B5 BN 90L 2	74
181	110	2.1	7.78	2420	AS 30_100 B5 BN 100LA 4	76
181	110	3.1	7.78	6690	AS 35_100 B5 BN 100LA 4	78
183	109	2.2	15.37	2390	AS 30_090 B5 BN 90L 2	76
183	109	3.3	15.37	6650	AS 35_090 B5 BN 90L 2	78
188	106	2.2	7.51	2360	AS 30_100 B5 BN 100LA 4	76
188	106	3.2	7.51	6590	AS 35_100 B5 BN 100LA 4	78
201	100	1.1	14.01	1070	AS 25_090 B5 BN 90L 2	74
203	98	2.3	6.93	2360	AS 30_100 B5 BN 100LA 4	76
203	98	3.5	6.93	6490	AS 35_100 B5 BN 100LA 4	78
223	90	2.7	12.62	2300	AS 30_090 B5 BN 90L 2	76
227	88	2.6	6.22	2310	AS 30_100 B5 BN 100LA 4	76
244	82	1.3	11.51	1070	AS 25_090 B5 BN 90L 2	74
246	81	2.6	11.43	2290	AS 30_090 B5 BN 90L 2	76
267	75	1.5	10.53	1060	AS 25_090 B5 BN 90L 2	74
276	72	3.2	5.11	2210	AS 30_100 B5 BN 100LA 4	76
276	72	2.9	10.18	2230	AS 30_090 B5 BN 90L 2	76
307	65	3.2	9.14	2170	AS 30_090 B5 BN 90L 2	76
315	63	1.7	8.93	1050	AS 25_090 B5 BN 90L 2	74

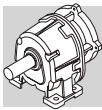

2.2 kW

n_2 min ⁻¹	M_2 Nm	S	i	Rn_2 N	IEC		
357	56	1.8	7.88	1060	AS 25_ 090 B5	BN 90L 2	74
361	55	3.3	7.78	2110	AS 30_ 090 B5	BN 90L 2	76
363	55	0.9	7.75	850	AS 20_ 090 B5	BN 90L 2	72
374	53	3.4	7.51	2070	AS 30_ 090 B5	BN 90L 2	76
434	46	2.2	6.47	1030	AS 25_ 090 B5	BN 90L 2	74
435	46	1.1	6.46	840	AS 20_ 090 B5	BN 90L 2	72
475	42	2.4	5.92	1020	AS 25_ 090 B5	BN 90L 2	74
512	39	1.3	5.49	820	AS 20_ 090 B5	BN 90L 2	72
559	36	2.8	5.02	990	AS 25_ 090 B5	BN 90L 2	74

3 kW

5.4	4909	1.4	173.2	42000	AS 90 D_ 132 B5	BN 132S 6	88
6.1	4390	1.5	154.9	42000	AS 90 D_ 132 B5	BN 132S 6	88
6.1	4369	1.0	154.1	31000	AS 80 D_ 132 B5	BN 132S 6	86
6.7	3951	1.7	139.4	42000	AS 90 D_ 132 B5	BN 132S 6	88
6.8	3932	1.1	138.7	31000	AS 80 D_ 132 B5	BN 132S 6	86
7.5	3575	1.9	126.1	42000	AS 90 D_ 132 B5	BN 132S 6	88
7.5	3558	1.2	125.5	31000	AS 80 D_ 132 B5	BN 132S 6	86
8.1	3273	1.9	173.2	42000	AS 90 D_ 100 B5	BN 100LB 4	88
8.2	3257	1.2	172.3	31000	AS 80 D_ 100 B5	BN 100LB 4	86
8.8	3017	1.4	106.5	31000	AS 80 D_ 132 B5	BN 132S 6	86
8.8	3017	2.3	106.5	42000	AS 90 D_ 132 B5	BN 132S 6	88
9.1	2927	2.1	154.9	42000	AS 90 D_ 100 B5	BN 100LB 4	88
9.1	2913	1.3	154.1	31000	AS 80 D_ 100 B5	BN 100LB 4	86
9.9	2698	1.6	95.2	31000	AS 80 D_ 132 B5	BN 132S 6	86
9.9	2698	2.5	95.2	42000	AS 90 D_ 132 B5	BN 132S 6	88
10.1	2634	2.4	139.4	42000	AS 90 D_ 100 B5	BN 100LB 4	88
10.2	2621	1.4	138.7	31000	AS 80 D_ 100 B5	BN 100LB 4	86
10.7	2497	0.9	88.1	22000	AS 60 D_ 132 B5	BN 132S 6	84
11.0	2429	1.7	85.7	31000	AS 80 D_ 132 B5	BN 132S 6	86
11.0	2429	2.8	85.7	42000	AS 90 D_ 132 B5	BN 132S 6	88
11.2	2383	2.6	126.1	42000	AS 90 D_ 100 B5	BN 100LB 4	88
11.2	2372	1.6	125.5	31000	AS 80 D_ 100 B5	BN 100LB 4	86
11.7	2286	0.9	121	22000	AS 60 D_ 100 B5	BN 100LB 4	84
12.1	2197	1.9	77.5	31000	AS 80 D_ 132 B5	BN 132S 6	86
12.1	2197	3.1	77.5	42000	AS 90 D_ 132 B5	BN 132S 6	88
12.3	2166	1.1	76.4	22000	AS 60 D_ 132 B5	BN 132S 6	84
13.0	2045	1.0	108.2	21900	AS 60 D_ 100 B5	BN 100LB 4	84
13.2	2012	1.9	106.5	31000	AS 80 D_ 100 B5	BN 100LB 4	86
13.2	2012	3.1	106.5	42000	AS 90 D_ 100 B5	BN 100LB 4	88
13.7	1950	2.2	68.8	31000	AS 80 D_ 132 B5	BN 132S 6	86
13.7	1950	3.5	68.8	42000	AS 90 D_ 132 B5	BN 132S 6	88
13.8	1937	1.2	68.3	21800	AS 60 D_ 132 B5	BN 132S 6	84
14.5	1840	1.1	97.4	21500	AS 60 D_ 100 B5	BN 100LB 4	84
14.8	1799	2.1	95.2	31000	AS 80 D_ 100 B5	BN 100LB 4	86
14.8	1799	3.4	95.2	42000	AS 90 D_ 100 B5	BN 100LB 4	88
16.0	1665	1.3	88.1	21100	AS 60 D_ 100 B5	BN 100LB 4	84
16.5	1619	2.3	85.7	31000	AS 80 D_ 100 B5	BN 100LB 4	86
18.2	1465	2.6	77.5	31000	AS 80 D_ 100 B5	BN 100LB 4	86
18.5	1444	1.5	76.4	21000	AS 60 D_ 100 B5	BN 100LB 4	84
20.5	1297	0.9	68.6	15000	AS 55 D_ 100 B5	BN 100LB 4	82
20.6	1291	1.6	68.3	20500	AS 60 D_ 100 B5	BN 100LB 4	84
22.9	1162	1.8	61.5	20000	AS 60 D_ 100 B5	BN 100LB 4	84
23.0	1156	1.0	61.2	15000	AS 55 D_ 100 B5	BN 100LB 4	82
25.3	1051	2.0	55.6	19600	AS 60 D_ 100 B5	BN 100LB 4	84
25.7	1038	1.2	54.9	15000	AS 55 D_ 100 B5	BN 100LB 4	82
34	795	1.5	42.1	15000	AS 55 D_ 100 B5	BN 100LB 4	82
34	784	2.7	41.5	18600	AS 60 D_ 100 B5	BN 100LB 4	84
37	722	1.0	38.2	9500	AS 45 D_ 100 B5	BN 100LB 4	80

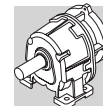

3 kW

n_2 min ⁻¹	M_2 Nm	S	i	Rn_2 N	IEC		
38	704	1.7	37.2	15000	AS 55 D_100 B5	BN 100LB 4	82
38	701	3.0	37.1	18100	AS 60 D_100 B5	BN 100LB 4	84
41	649	1.1	34.4	9500	AS 45 D_100 B5	BN 100LB 4	80
42	631	3.3	33.4	17600	AS 60 D_100 B5	BN 100LB 4	84
42	628	1.9	33.2	15000	AS 55 D_100 B5	BN 100LB 4	82
45	588	1.2	31.1	9500	AS 45 D_100 B5	BN 100LB 4	80
47	563	2.1	29.8	15000	AS 55 D_100 B5	BN 100LB 4	82
51	530	1.4	27.45	9220	AS 45_100 B5	BN 100LB 4	80
55	499	2.4	25.84	15000	AS 55_100 B5	BN 100LB 4	82
57	474	1.5	24.55	9050	AS 45_100 B5	BN 100LB 4	80
58	467	1.0	24.19	7200	AS 35_100 B5	BN 100LB 4	78
62	442	2.7	22.87	15000	AS 55_100 B5	BN 100LB 4	82
64	426	1.7	22.09	8880	AS 45_100 B5	BN 100LB 4	80
69	394	3.0	20.4	15000	AS 55_100 B5	BN 100LB 4	82
71	386	1.9	19.99	8710	AS 45_100 B5	BN 100LB 4	80
73	371	1.1	19.21	7200	AS 35_100 B5	BN 100LB 4	78
77	353	3.4	18.31	15000	AS 55_100 B5	BN 100LB 4	82
80	342	1.9	17.7	8640	AS 45_100 B5	BN 100LB 4	80
82	330	1.2	17.11	7200	AS 35_100 B5	BN 100LB 4	78
89	306	2.1	15.83	8440	AS 45_100 B5	BN 100LB 4	80
92	297	1.3	15.37	7200	AS 35_100 B5	BN 100LB 4	78
99	275	2.4	14.25	8250	AS 45_100 B5	BN 100LB 4	80
109	249	2.6	12.89	8070	AS 45_100 B5	BN 100LB 4	80
112	244	1.1	12.62	2070	AS 30_100 B5	BN 100LB 4	76
112	244	1.6	12.62	7030	AS 35_100 B5	BN 100LB 4	78
123	221	1.2	11.43	2190	AS 30_100 B5	BN 100LB 4	76
123	221	1.8	11.43	6990	AS 35_100 B5	BN 100LB 4	78
126	216	3.0	11.18	7900	AS 45_100 B5	BN 100LB 4	80
138	197	1.3	10.18	2180	AS 30_100 B5	BN 100LB 4	76
138	197	2.0	10.18	6820	AS 35_100 B5	BN 100LB 4	78
141	193	3.4	10	7690	AS 45_100 B5	BN 100LB 4	80
154	176	1.5	9.14	2160	AS 30_100 B5	BN 100LB 4	76
154	176	2.3	9.14	6670	AS 35_100 B5	BN 100LB 4	78
167	163	1.5	17.11	2180	AS 30_100 B5	BN 100L 2	76
167	163	2.2	17.11	6570	AS 35_100 B5	BN 100L 2	78
181	150	1.5	7.78	2180	AS 30_100 B5	BN 100LB 4	76
181	150	2.3	7.78	6470	AS 35_100 B5	BN 100LB 4	78
186	146	1.6	15.37	2150	AS 30_100 B5	BN 100L 2	76
186	146	2.5	15.37	6410	AS 35_100 B5	BN 100L 2	78
188	145	1.6	7.51	2120	AS 30_100 B5	BN 100LB 4	76
188	145	2.3	7.51	6370	AS 35_100 B5	BN 100LB 4	78
203	134	1.7	6.93	2150	AS 30_100 B5	BN 100LB 4	76
203	134	2.5	6.93	6300	AS 35_100 B5	BN 100LB 4	78
227	120	2.0	12.62	2090	AS 30_100 B5	BN 100L 2	76
227	120	3.0	12.62	6120	AS 35_100 B5	BN 100L 2	78
227	120	1.9	6.22	2110	AS 30_100 B5	BN 100LB 4	76
227	120	2.8	6.22	6140	AS 35_100 B5	BN 100LB 4	78
250	109	1.9	11.43	2110	AS 30_100 B5	BN 100L 2	76
250	109	2.9	11.43	6020	AS 35_100 B5	BN 100L 2	78
276	99	2.3	5.11	2040	AS 30_100 B5	BN 100LB 4	76
276	99	3.4	5.11	5850	AS 35_100 B5	BN 100LB 4	78
281	97	2.2	10.18	2070	AS 30_100 B5	BN 100L 2	76
281	97	3.3	10.18	5850	AS 35_100 B5	BN 100L 2	78
313	87	2.4	9.14	2030	AS 30_100 B5	BN 100L 2	76
368	74	2.4	7.78	1980	AS 30_100 B5	BN 100L 2	76
381	71	2.5	7.51	1940	AS 30_100 B5	BN 100L 2	76
413	66	2.7	6.93	1930	AS 30_100 B5	BN 100L 2	76
460	59	3.0	6.22	1890	AS 30_100 B5	BN 100L 2	76
521	52	1.0	5.49	700	AS 20_100 B5	BN 100L 2	72

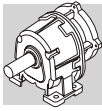

4 kW

n_2 min ⁻¹	M_2 Nm	S	i	Rn_2 N		
5.5	6477	1.0	173.2	42000	AS 90 D_132 B5 BN 132MA 6	88
6.1	5792	1.2	154.9	42000	AS 90 D_132 B5 BN 132MA 6	88
6.8	5213	1.3	139.4	42000	AS 90 D_132 B5 BN 132MA 6	88
7.5	4717	1.4	126.1	42000	AS 90 D_132 B5 BN 132MA 6	88
8.0	4427	1.4	173.2	42000	AS 90 D_112 B5 BN 112M 4	88
8.9	3981	1.1	106.5	31000	AS 80 D_132 B5 BN 132MA 6	86
8.9	3981	1.7	106.5	42000	AS 90 D_132 B5 BN 132MA 6	88
9.0	3959	1.6	154.9	42000	AS 90 D_112 B5 BN 112M 4	88
9.0	3939	1.0	154.1	31000	AS 80 D_112 B5 BN 112M 4	86
10.0	3563	1.7	139.4	42000	AS 90 D_112 B5 BN 112M 4	88
10.0	3560	1.2	95.2	31000	AS 80 D_132 B5 BN 132MA 6	86
10.0	3560	1.9	95.2	42000	AS 90 D_132 B5 BN 132MA 6	88
10.0	3545	1.1	138.7	31000	AS 80 D_112 B5 BN 112M 4	86
11.0	3224	1.9	126.1	42000	AS 90 D_112 B5 BN 112M 4	88
11.1	3208	1.2	125.5	31000	AS 80 D_112 B5 BN 112M 4	86
11.1	3204	1.3	85.7	31000	AS 80 D_132 B5 BN 132MA 6	86
11.1	3204	2.1	85.7	42000	AS 90 D_132 B5 BN 132MA 6	88
12.3	2899	1.4	77.5	31000	AS 80 D_132 B5 BN 132MA 6	86
12.3	2899	2.3	77.5	42000	AS 90 D_132 B5 BN 132MA 6	88
13.1	2721	1.4	106.5	31000	AS 80 D_112 B5 BN 112M 4	86
13.1	2721	2.3	106.5	42000	AS 90 D_112 B5 BN 112M 4	88
13.8	2573	1.6	68.8	31000	AS 80 D_132 B5 BN 132MA 6	86
13.8	2573	2.6	68.8	42000	AS 90 D_132 B5 BN 132MA 6	88
13.9	2555	0.9	68.3	20000	AS 60 D_132 B5 BN 132MA 6	84
14.6	2433	1.6	95.2	31000	AS 80 D_112 B5 BN 112M 4	86
14.6	2433	2.5	95.2	42000	AS 90 D_112 B5 BN 112M 4	88
15.8	2252	0.9	88.1	19500	AS 60 D_112 B5 BN 112M 4	84
16.2	2190	1.7	85.7	31000	AS 80 D_112 B5 BN 112M 4	86
16.2	2190	2.8	85.7	42000	AS 90 D_112 B5 BN 112M 4	88
17.9	1981	1.9	77.5	31000	AS 80 D_112 B5 BN 112M 4	86
17.9	1981	3.1	77.5	42000	AS 90 D_112 B5 BN 112M 4	88
18.2	1953	1.1	76.4	19700	AS 60 D_112 B5 BN 112M 4	84
20.3	1746	1.2	68.3	19300	AS 60 D_112 B5 BN 112M 4	84
22.6	1572	1.3	61.5	18900	AS 60 D_112 B5 BN 112M 4	84
25.0	1422	1.5	55.6	18600	AS 60 D_112 B5 BN 112M 4	84
33	1076	1.1	42.1	15000	AS 55 D_112 B5 BN 112M 4	82
34	1060	2.0	41.5	17900	AS 60 D_112 B5 BN 112M 4	84
37	952	1.3	37.2	15000	AS 55 D_112 B5 BN 112M 4	82
37	948	2.2	37.1	17500	AS 60 D_112 B5 BN 112M 4	84
42	853	2.5	33.4	17100	AS 60 D_112 B5 BN 112M 4	84
42	849	1.4	33.2	15000	AS 55 D_112 B5 BN 112M 4	82
45	795	0.9	31.1	9140	AS 45 D_112 B5 BN 112M 4	80
46	772	2.7	30.2	16700	AS 60 D_112 B5 BN 112M 4	84
47	762	1.6	29.8	15000	AS 55 D_112 B5 BN 112M 4	82
51	717	1.0	27.45	8420	AS 45_112 B5 BN 112M 4	80
54	675	1.8	25.84	15000	AS 55_112 B5 BN 112M 4	82
57	641	1.1	24.55	8320	AS 45_112 B5 BN 112M 4	80
61	597	2.0	22.87	15000	AS 55_112 B5 BN 112M 4	82
63	577	1.2	22.09	8220	AS 45_112 B5 BN 112M 4	80
68	533	2.3	20.4	15000	AS 55_112 B5 BN 112M 4	82
70	522	1.4	19.99	8100	AS 45_112 B5 BN 112M 4	80
76	478	2.5	18.31	15000	AS 55_112 B5 BN 112M 4	82
79	462	1.4	17.7	8140	AS 45_112 B5 BN 112M 4	80
87	417	2.6	15.96	15000	AS 55_112 B5 BN 112M 4	82
88	413	1.6	15.83	7980	AS 45_112 B5 BN 112M 4	80
90	401	1.0	15.37	6760	AS 35_112 B5 BN 112M 4	78
98	372	1.7	14.25	7830	AS 45_112 B5 BN 112M 4	80
98	369	3.0	14.13	14900	AS 55_112 B5 BN 112M 4	82
108	337	1.9	12.89	7680	AS 45_112 B5 BN 112M 4	80
110	330	1.2	12.62	6580	AS 35_112 B5 BN 112M 4	78

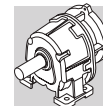

4 kW

n_2 min ⁻¹	M_2 Nm	S	i	Rn_2 N	IEC	
110	329	3.3	12.6	14500	AS 55_ 112 B5 BN 112M 4	82
122	298	1.3	11.43	6610	AS 35_ 112 B5 BN 112M 4	78
124	292	2.2	11.18	7590	AS 45_ 112 B5 BN 112M 4	80
137	266	1.0	10.18	1780	AS 30_ 112 B5 BN 112M 4	76
137	266	1.5	10.18	6480	AS 35_ 112 B5 BN 112M 4	78
139	261	2.5	10	7410	AS 45_ 112 B5 BN 112M 4	80
152	239	1.1	9.14	1800	AS 30_ 112 B5 BN 112M 4	76
152	239	1.7	9.14	6360	AS 35_ 112 B5 BN 112M 4	78
154	235	2.8	9	7250	AS 45_ 112 B5 BN 112M 4	80
162	224	2.6	17.7	7220	AS 45_ 100 B5 BN 100LB 2	80
168	216	1.1	17.11	1850	AS 30_ 100 B5 BN 100LB 2	76
168	216	1.7	17.11	6280	AS 35_ 100 B5 BN 100LB 2	78
171	213	3.1	8.14	7080	AS 45_ 112 B5 BN 112M 4	80
179	203	1.1	7.78	1890	AS 30_ 112 B5 BN 112M 4	76
179	203	1.7	7.78	6220	AS 35_ 112 B5 BN 112M 4	78
181	200	2.9	15.83	7040	AS 45_ 100 B5 BN 100LB 2	80
185	196	1.2	7.51	1810	AS 30_ 112 B5 BN 112M 4	76
185	196	1.7	7.51	6110	AS 35_ 112 B5 BN 112M 4	78
187	194	1.2	15.37	1850	AS 30_ 100 B5 BN 100LB 2	76
187	194	1.9	15.37	6140	AS 35_ 100 B5 BN 100LB 2	78
201	181	1.3	6.93	1880	AS 30_ 112 B5 BN 112M 4	76
201	181	1.9	6.93	6080	AS 35_ 112 B5 BN 112M 4	78
201	180	3.3	14.25	6860	AS 45_ 100 B5 BN 100LB 2	80
223	162	1.4	6.22	1870	AS 30_ 112 B5 BN 112M 4	76
223	162	2.1	6.22	5940	AS 35_ 112 B5 BN 112M 4	78
227	160	1.5	12.62	1840	AS 30_ 100 B5 BN 100LB 2	76
227	160	2.3	12.62	5890	AS 35_ 100 B5 BN 100LB 2	78
229	158	3.3	6.07	6700	AS 45_ 112 B5 BN 112M 4	80
251	145	1.5	11.43	1900	AS 30_ 100 B5 BN 100LB 2	76
251	145	2.2	11.43	5830	AS 35_ 100 B5 BN 100LB 2	78
272	133	1.7	5.11	1840	AS 30_ 112 B5 BN 112M 4	76
272	133	2.5	5.11	5680	AS 35_ 112 B5 BN 112M 4	78
282	129	1.6	10.18	1880	AS 30_ 100 B5 BN 100LB 2	76
282	129	2.5	10.18	5680	AS 35_ 100 B5 BN 100LB 2	78
314	116	1.8	9.14	1850	AS 30_ 100 B5 BN 100LB 2	76
314	116	2.8	9.14	5530	AS 35_ 100 B5 BN 100LB 2	78
369	98	1.8	7.78	1840	AS 30_ 100 B5 BN 100LB 2	76
369	98	2.7	7.78	5350	AS 35_ 100 B5 BN 100LB 2	78
382	95	1.9	7.51	1790	AS 30_ 100 B5 BN 100LB 2	76
382	95	2.8	7.51	5280	AS 35_ 100 B5 BN 100LB 2	78
414	88	2.1	6.93	1800	AS 30_ 100 B5 BN 100LB 2	76
414	88	3.1	6.93	5200	AS 35_ 100 B5 BN 100LB 2	78
461	79	2.3	6.22	1770	AS 30_ 100 B5 BN 100LB 2	76
461	79	3.4	6.22	5060	AS 35_ 100 B5 BN 100LB 2	78
562	65	2.8	5.11	1690	AS 30_ 100 B5 BN 100LB 2	76

5.5 kW

6.8	7206	0.9	139.4	42000	AS 90 D_132 B5 BN 132MB 6	88
7.5	6520	1.0	126.1	42000	AS 90 D_132 B5 BN 132MB 6	88
8.3	5875	1.1	173.2	42000	AS 90 D_132 B5 BN 132S 4	88
8.9	5503	1.2	106.5	42000	AS 90 D_132 B5 BN 132MB 6	88
9.3	5254	1.2	154.9	42000	AS 90 D_132 B5 BN 132S 4	88
9.9	4921	1.4	95.2	42000	AS 90 D_132 B5 BN 132MB 6	88
10.3	4729	1.3	139.4	42000	AS 90 D_132 B5 BN 132S 4	88
11.0	4429	0.9	85.7	31000	AS 80 D_132 B5 BN 132MB 6	86
11.0	4429	1.5	85.7	42000	AS 90 D_132 B5 BN 132MB 6	88
11.4	4278	1.4	126.1	42000	AS 90 D_132 B5 BN 132S 4	88
12.2	4007	1.0	77.5	31000	AS 80 D_132 B5 BN 132MB 6	86

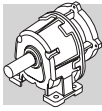

5.5 kW

n_2 min ⁻¹	M_2 Nm	S	i	Rn_2 N			
12.2	4007	1.7	77.5	42000	AS 90 D_132 B5	BN 132MB 6	88
13.5	3611	1.1	106.5	31000	AS 80 D_132 B5	BN 132S 4	86
13.5	3611	1.7	106.5	42000	AS 90 D_132 B5	BN 132S 4	88
13.7	3556	1.2	68.8	31000	AS 80 D_132 B5	BN 132MB 6	86
13.7	3556	1.9	68.8	42000	AS 90 D_132 B5	BN 132MB 6	88
15.1	3229	1.2	95.2	31000	AS 80 D_132 B5	BN 132S 4	86
15.1	3229	1.9	95.2	42000	AS 90 D_132 B5	BN 132S 4	88
16.8	2906	1.3	85.7	31000	AS 80 D_132 B5	BN 132S 4	86
16.8	2906	2.1	85.7	42000	AS 90 D_132 B5	BN 132S 4	88
18.6	2630	1.4	77.5	31000	AS 80 D_132 B5	BN 132S 4	86
18.6	2630	2.4	77.5	42000	AS 90 D_132 B5	BN 132S 4	88
20.9	2334	1.6	68.8	31000	AS 80 D_132 B5	BN 132S 4	86
20.9	2334	2.7	68.8	42000	AS 90 D_132 B5	BN 132S 4	88
21.1	2318	0.9	68.3	17400	AS 60 D_132 B5	BN 132S 4	84
23.4	2087	1.8	61.5	31000	AS 80 D_132 B5	BN 132S 4	86
23.4	2087	3.0	61.5	42000	AS 90 D_132 B5	BN 132S 4	88
23.4	2086	1.0	61.5	17200	AS 60 D_132 B5	BN 132S 4	84
25.9	1888	1.1	55.6	16900	AS 60 D_132 B5	BN 132S 4	84
26.0	1878	2.0	55.4	31000	AS 80 D_132 B5	BN 132S 4	86
26.0	1878	3.3	55.4	42000	AS 90 D_132 B5	BN 132S 4	88
28.7	1699	2.2	50.1	31000	AS 80 D_132 B5	BN 132S 4	86
34	1453	2.6	42.8	31000	AS 80 D_132 B5	BN 132S 4	86
35	1407	1.5	41.5	16800	AS 60 D_132 B5	BN 132S 4	84
38	1299	2.9	38.3	31000	AS 80 D_132 B5	BN 132S 4	86
39	1264	0.9	37.2	15000	AS 55 D_132 B5	BN 132S 4	82
39	1258	1.7	37.1	16400	AS 60 D_132 B5	BN 132S 4	84
42	1169	3.2	34.5	31000	AS 80 D_132 B5	BN 132S 4	86
43	1133	1.9	33.4	16100	AS 60 D_132 B5	BN 132S 4	84
43	1127	1.1	33.2	15000	AS 55 D_132 B5	BN 132S 4	82
48	1025	2.0	30.2	15700	AS 60 D_132 B5	BN 132S 4	84
48	1011	1.2	29.8	15000	AS 55 D_132 B5	BN 132S 4	82
56	895	1.3	25.84	15000	AS 55_132 B5	BN 132S 4	82
57	883	2.4	25.47	14800	AS 60_132 B5	BN 132S 4	84
63	793	1.5	22.87	15000	AS 55_132 B5	BN 132S 4	82
63	789	2.7	22.78	14400	AS 60_132 B5	BN 132S 4	84
65	765	0.9	22.09	7210	AS 45_132 B5	BN 132S 4	80
70	710	3.0	20.5	14100	AS 60_132 B5	BN 132S 4	84
71	707	1.7	20.4	15000	AS 55_132 B5	BN 132S 4	82
72	693	1.0	19.99	7170	AS 45_132 B5	BN 132S 4	80
78	643	3.3	18.55	13800	AS 60_132 B5	BN 132S 4	84
79	634	1.9	18.31	14700	AS 55_132 B5	BN 132S 4	82
81	613	1.1	17.7	7340	AS 45_132 B5	BN 132S 4	80
90	553	2.0	15.96	14500	AS 55_132 B5	BN 132S 4	82
91	549	1.2	15.83	7250	AS 45_132 B5	BN 132S 4	80
101	494	1.3	14.25	7160	AS 45_132 B5	BN 132S 4	80
102	490	2.2	14.13	14200	AS 55_132 B5	BN 132S 4	82
112	447	1.5	12.89	7060	AS 45_132 B5	BN 132S 4	80
114	437	2.5	12.6	13800	AS 55_132 B5	BN 132S 4	82
127	392	2.8	11.31	13500	AS 55_132 B5	BN 132S 4	82
129	387	1.7	11.18	7060	AS 45_132 B5	BN 132S 4	80
140	357	3.1	10.31	13300	AS 55_132 B5	BN 132S 4	82
144	347	1.9	10	6930	AS 45_132 B5	BN 132S 4	80
158	316	3.5	9.13	13000	AS 55_132 B5	BN 132S 4	82
160	312	2.1	9	6790	AS 45_132 B5	BN 132S 4	80
163	306	1.9	17.7	6830	AS 45_132 B5	BN 132SA 2	80
177	282	2.3	8.14	6660	AS 45_132 B5	BN 132S 4	80
183	273	2.2	15.83	6680	AS 45_132 B5	BN 132SA 2	80
203	246	2.4	14.25	6540	AS 45_132 B5	BN 132SA 2	80
224	223	2.7	12.89	6400	AS 45_132 B5	BN 132SA 2	80
237	210	2.5	6.07	6390	AS 45_132 B5	BN 132S 4	80

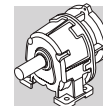

5.5 kW

n_2 min ⁻¹	M_2 Nm	S	i	Rn_2 N	IEC	
258	193	2.7	11.18	6280	AS 45_ 132 B5 BN 132SA 2	80
265	188	2.8	5.43	6230	AS 45_ 132 B5 BN 132S 4	80
289	173	3.0	10	6120	AS 45_ 132 B5 BN 132SA 2	80
295	169	3.1	4.89	6080	AS 45_ 132 B5 BN 132S 4	80
321	155	3.3	9	5970	AS 45_ 132 B5 BN 132SA 2	80
326	153	3.4	4.42	5940	AS 45_ 132 B5 BN 132S 4	80

7.5 kW

9.0	7425	0.9	106.5	42000	AS 90 D_160 B5 BN 160M 6	88
10.0	6640	1.0	95.2	42000	AS 90 D_160 B5 BN 160M 6	88
10.3	6448	1.0	139.4	42000	AS 90 D_132 B5 BN 132MA 4	88
11.1	5976	1.1	85.7	42000	AS 90 D_160 B5 BN 160M 6	88
11.4	5834	1.1	126.1	42000	AS 90 D_132 B5 BN 132MA 4	88
12.3	5407	1.3	77.5	42000	AS 90 D_160 B5 BN 160M 6	88
13.5	4924	1.3	106.5	42000	AS 90 D_132 B5 BN 132MA 4	88
13.9	4798	1.4	68.8	42000	AS 90 D_160 B5 BN 160M 6	88
15.1	4404	1.4	95.2	42000	AS 90 D_132 B5 BN 132MA 4	88
16.8	3963	1.0	85.7	31000	AS 80 D_132 B5 BN 132MA 4	86
16.8	3963	1.6	85.7	42000	AS 90 D_132 B5 BN 132MA 4	88
18.6	3586	1.1	77.5	31000	AS 80 D_132 B5 BN 132MA 4	86
18.6	3586	1.7	77.5	42000	AS 90 D_132 B5 BN 132MA 4	88
20.9	3182	1.2	68.8	31000	AS 80 D_132 B5 BN 132MA 4	86
20.9	3182	1.9	68.8	42000	AS 90 D_132 B5 BN 132MA 4	88
23.4	2846	1.3	61.5	31000	AS 80 D_132 B5 BN 132MA 4	86
23.4	2846	2.2	61.5	42000	AS 90 D_132 B5 BN 132MA 4	88
26.0	2561	1.5	55.4	31000	AS 80 D_132 B5 BN 132MA 4	86
26.0	2561	2.4	55.4	42000	AS 90 D_132 B5 BN 132MA 4	88
28.7	2317	1.6	50.1	31000	AS 80 D_132 B5 BN 132MA 4	86
28.7	2317	2.7	50.1	42000	AS 90 D_132 B5 BN 132MA 4	88
34	1981	1.9	42.8	31000	AS 80 D_132 B5 BN 132MA 4	86
35	1919	1.1	41.5	15300	AS 60 D_132 B5 BN 132MA 4	84
36	1876	3.3	40.6	42000	AS 90 D_132 B5 BN 132MA 4	88
38	1772	2.1	38.3	31000	AS 80 D_132 B5 BN 132MA 4	86
39	1716	1.2	37.1	15100	AS 60 D_132 B5 BN 132MA 4	84
42	1594	2.4	34.5	31000	AS 80 D_132 B5 BN 132MA 4	86
43	1544	1.4	33.4	14900	AS 60 D_132 B5 BN 132MA 4	84
46	1443	2.6	31.2	31000	AS 80 D_132 B5 BN 132MA 4	86
48	1397	1.5	30.2	14600	AS 60 D_132 B5 BN 132MA 4	84
56	1221	1.0	25.84	14100	AS 55_ 132 B5 BN 132MA 4	82
57	1204	1.7	25.47	13600	AS 60_ 132 B5 BN 132MA 4	84
63	1081	1.1	22.87	13900	AS 55_ 132 B5 BN 132MA 4	82
63	1076	2.0	22.78	13400	AS 60_ 132 B5 BN 132MA 4	84
70	969	2.2	20.5	13200	AS 60_ 132 B5 BN 132MA 4	84
71	964	1.2	20.4	13700	AS 55_ 132 B5 BN 132MA 4	82
78	876	2.4	18.55	13000	AS 60_ 132 B5 BN 132MA 4	84
79	865	1.4	18.31	13500	AS 55_ 132 B5 BN 132MA 4	82
90	754	1.5	15.96	13600	AS 55_ 132 B5 BN 132MA 4	82
92	740	2.6	15.65	12800	AS 60_ 132 B5 BN 132MA 4	84
101	673	1.0	14.25	6310	AS 45_ 132 B5 BN 132MA 4	80
102	668	1.6	14.13	13300	AS 55_ 132 B5 BN 132MA 4	82
103	662	2.9	14	12500	AS 60_ 132 B5 BN 132MA 4	84
112	609	1.1	12.89	6270	AS 45_ 132 B5 BN 132MA 4	80
114	595	1.8	12.6	13000	AS 55_ 132 B5 BN 132MA 4	82
114	595	3.2	12.6	12300	AS 60_ 132 B5 BN 132MA 4	84
127	534	2.1	11.31	12800	AS 55_ 132 B5 BN 132MA 4	82
129	528	1.2	11.18	6420	AS 45_ 132 B5 BN 132MA 4	80
140	487	2.3	10.31	12700	AS 55_ 132 B5 BN 132MA 4	82

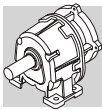

7.5 kW

n_2 min ⁻¹	M_2 Nm	S	i	Rn_2 N	IEC	
144	473	1.4	10	6350	AS 45_ 132 B5	BN 132MA 4 80
158	431	2.5	9.13	12400	AS 55_ 132 B5	BN 132MA 4 82
158	430	2.8	18.31	12300	AS 55_ 132 B5	BN 132SB 2 82
160	425	1.5	9	6260	AS 45_ 132 B5	BN 132MA 4 80
164	415	1.4	17.7	6320	AS 45_ 132 B5	BN 132SB 2 80
177	385	1.7	8.14	6170	AS 45_ 132 B5	BN 132MA 4 80
177	385	2.9	8.14	12100	AS 55_ 132 B5	BN 132MA 4 82
182	374	2.7	15.96	12100	AS 55_ 132 B5	BN 132SB 2 82
183	372	1.6	15.83	6220	AS 45_ 132 B5	BN 132SB 2 80
197	345	3.2	7.31	11800	AS 55_ 132 B5	BN 132MA 4 82
204	334	1.8	14.25	6110	AS 45_ 132 B5	BN 132SB 2 80
205	331	3.0	14.13	11800	AS 55_ 132 B5	BN 132SB 2 82
224	303	2.6	6.42	11600	AS 55_ 132 B5	BN 132MA 4 82
225	303	2.0	12.89	6010	AS 45_ 132 B5	BN 132SB 2 80
230	296	3.4	12.6	11500	AS 55_ 132 B5	BN 132SB 2 82
237	287	1.8	6.07	6040	AS 45_ 132 B5	BN 132MA 4 80
253	269	3.0	5.68	11300	AS 55_ 132 B5	BN 132MA 4 82
259	262	2.0	11.18	5960	AS 45_ 132 B5	BN 132SB 2 80
265	257	2.0	5.43	5920	AS 45_ 132 B5	BN 132MA 4 80
284	240	3.3	5.07	11000	AS 55_ 132 B5	BN 132MA 4 82
290	235	2.2	10	5830	AS 45_ 132 B5	BN 132SB 2 80
295	231	2.3	4.89	5790	AS 45_ 132 B5	BN 132MA 4 80
322	211	2.5	9	5700	AS 45_ 132 B5	BN 132SB 2 80
326	209	2.5	4.42	5670	AS 45_ 132 B5	BN 132MA 4 80
356	191	2.7	8.14	5580	AS 45_ 132 B5	BN 132SB 2 80
478	142	2.9	6.07	5310	AS 45_ 132 B5	BN 132SB 2 80
534	127	3.3	5.43	5170	AS 45_ 132 B5	BN 132SB 2 80

9.2 kW

13.5	6040	1.0	106.5	42000	AS 90 D_ 132 B5	BN 132MB 4 88
15.1	5402	1.1	95.2	42000	AS 90 D_ 132 B5	BN 132MB 4 88
16.8	4862	1.3	85.7	42000	AS 90 D_ 132 B5	BN 132MB 4 88
18.6	4399	1.4	77.5	42000	AS 90 D_ 132 B5	BN 132MB 4 88
20.9	3904	1.0	68.8	31000	AS 80 D_ 132 B5	BN 132MB 4 86
20.9	3904	1.6	68.8	42000	AS 90 D_ 132 B5	BN 132MB 4 88
23.4	3491	1.1	61.5	31000	AS 80 D_ 132 B5	BN 132MB 4 86
23.4	3491	1.8	61.5	42000	AS 90 D_ 132 B5	BN 132MB 4 88
26.0	3142	1.2	55.4	31000	AS 80 D_ 132 B5	BN 132MB 4 86
26.0	3142	2.0	55.4	42000	AS 90 D_ 132 B5	BN 132MB 4 88
28.7	2843	1.3	50.1	31000	AS 80 D_ 132 B5	BN 132MB 4 86
28.7	2843	2.2	50.1	42000	AS 90 D_ 132 B5	BN 132MB 4 88
34	2430	1.6	42.8	31000	AS 80 D_ 132 B5	BN 132MB 4 86
36	2301	2.7	40.6	42000	AS 90 D_ 132 B5	BN 132MB 4 88
38	2173	1.7	38.3	31000	AS 80 D_ 132 B5	BN 132MB 4 86
39	2105	1.0	37.1	14000	AS 60 D_ 132 B5	BN 132MB 4 84
40	2058	3.0	36.3	42000	AS 90 D_ 132 B5	BN 132MB 4 88
42	1956	1.9	34.5	31000	AS 80 D_ 132 B5	BN 132MB 4 86
43	1894	1.1	33.4	13800	AS 60 D_ 132 B5	BN 132MB 4 84
44	1852	3.3	32.6	42000	AS 90 D_ 132 B5	BN 132MB 4 88
46	1770	2.1	31.2	31000	AS 80 D_ 132 B5	BN 132MB 4 86
48	1714	1.2	30.2	13700	AS 60 D_ 132 B5	BN 132MB 4 84
57	1476	1.4	25.47	12700	AS 60_ 132 B5	BN 132MB 4 84
63	1326	0.9	22.87	12800	AS 55_ 132 B5	BN 132MB 4 82
63	1320	1.6	22.78	12600	AS 60_ 132 B5	BN 132MB 4 84
70	1188	1.8	20.5	12400	AS 60_ 132 B5	BN 132MB 4 84
71	1182	1.0	20.4	12700	AS 55_ 132 B5	BN 132MB 4 82
78	1075	2.0	18.55	12200	AS 60_ 132 B5	BN 132MB 4 84

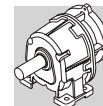

9.2 kW



n_2 min ⁻¹	M_2 Nm	S	i	Rn_2 N	IEC	
79	1061	1.1	18.31	12500	AS 55_ 132 B5	BN 132MB 4 82
90	925	1.2	15.96	12800	AS 55_ 132 B5	BN 132MB 4 82
92	907	2.1	15.65	12200	AS 60_ 132 B5	BN 132MB 4 84
102	819	1.3	14.13	12600	AS 55_ 132 B5	BN 132MB 4 82
103	811	2.3	14	12000	AS 60_ 132 B5	BN 132MB 4 84
114	730	1.5	12.6	12400	AS 55_ 132 B5	BN 132MB 4 82
114	730	2.6	12.6	11800	AS 60_ 132 B5	BN 132MB 4 84
126	661	2.9	11.4	11600	AS 60_ 132 B5	BN 132MB 4 84
127	655	1.7	11.31	12200	AS 55_ 132 B5	BN 132MB 4 82
129	648	1.0	11.18	5880	AS 45_ 132 B5	BN 132MB 4 80
140	598	1.8	10.31	12200	AS 55_ 132 B5	BN 132MB 4 82
142	586	3.2	10.12	11500	AS 60_ 132 B5	BN 132MB 4 84
144	580	1.1	10	5850	AS 45_ 132 B5	BN 132MB 4 80
158	529	2.1	9.13	12000	AS 55_ 132 B5	BN 132MB 4 82
158	527	2.3	18.31	11800	AS 55_ 132 B5	BN 132M 2 82
160	522	1.2	9	5810	AS 45_ 132 B5	BN 132MB 4 80
164	510	1.2	17.7	5890	AS 45_ 132 B5	BN 132M 2 80
177	472	1.4	8.14	5750	AS 45_ 132 B5	BN 132MB 4 80
177	472	2.3	8.14	11700	AS 55_ 132 B5	BN 132MB 4 82
182	459	2.2	15.96	11700	AS 55_ 132 B5	BN 132M 2 82
183	456	1.3	15.83	5830	AS 45_ 132 B5	BN 132M 2 80
197	424	2.6	7.31	11400	AS 55_ 132 B5	BN 132MB 4 82
204	410	1.4	14.25	5760	AS 45_ 132 B5	BN 132M 2 80
205	407	2.5	14.13	11400	AS 55_ 132 B5	BN 132M 2 82
224	372	2.1	6.42	11300	AS 55_ 132 B5	BN 132MB 4 82
225	371	1.6	12.89	5680	AS 45_ 132 B5	BN 132M 2 80
230	363	2.8	12.6	11100	AS 55_ 132 B5	BN 132M 2 82
237	352	1.5	6.07	5750	AS 45_ 132 B5	BN 132MB 4 80
253	329	2.4	5.68	11000	AS 55_ 132 B5	BN 132MB 4 82
256	325	3.1	11.31	10900	AS 55_ 132 B5	BN 132M 2 82
259	322	1.6	11.18	5690	AS 45_ 132 B5	BN 132M 2 80
265	315	1.7	5.43	5650	AS 45_ 132 B5	BN 132MB 4 80
281	297	3.0	10.31	10800	AS 55_ 132 B5	BN 132M 2 82
284	294	2.7	5.07	10700	AS 55_ 132 B5	BN 132MB 4 82
290	288	1.8	10	5580	AS 45_ 132 B5	BN 132M 2 80
295	283	1.8	4.89	5550	AS 45_ 132 B5	BN 132MB 4 80
317	264	3.0	4.55	10400	AS 55_ 132 B5	BN 132MB 4 82
318	263	3.4	9.13	10500	AS 55_ 132 B5	BN 132M 2 82
322	259	2.0	9	5480	AS 45_ 132 B5	BN 132M 2 80
326	256	2.0	4.42	5440	AS 45_ 132 B5	BN 132MB 4 80
356	234	2.2	8.14	5370	AS 45_ 132 B5	BN 132M 2 80
452	185	3.5	6.42	9700	AS 55_ 132 B5	BN 132M 2 82
478	175	2.4	6.07	5160	AS 45_ 132 B5	BN 132M 2 80
534	156	2.7	5.43	5030	AS 45_ 132 B5	BN 132M 2 80
594	141	3.0	4.89	4910	AS 45_ 132 B5	BN 132M 2 80
656	127	3.3	4.42	4800	AS 45_ 132 B5	BN 132M 2 80

11 kW

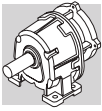
14.0	7001	1.0	68.8	42000	AS 90 D_160 B5	BN 160L 6 88
15.1	6459	1.0	95.2	42000	AS 90 D_160 B5	BN 160MR 4 88
16.8	5813	1.1	85.7	42000	AS 90 D_160 B5	BN 160MR 4 88
18.6	5259	1.2	77.5	42000	AS 90 D_160 B5	BN 160MR 4 88
20.9	4667	1.3	68.8	42000	AS 90 D_160 B5	BN 160MR 4 88
23.4	4174	0.9	61.5	31000	AS 80 D_160 B5	BN 160MR 4 86
23.4	4174	1.5	61.5	42000	AS 90 D_160 B5	BN 160MR 4 88
26.0	3757	1.0	55.4	31000	AS 80 D_160 B5	BN 160MR 4 86
26.0	3757	1.7	55.4	42000	AS 90 D_160 B5	BN 160MR 4 88



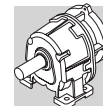

11 kW

n_2 min ⁻¹	M_2 Nm	S	i	Rn_2 N		
28.7	3399	1.1	50.1	31000	AS 80 D_160 B5 BN 160MR 4	86
28.7	3399	1.8	50.1	42000	AS 90 D_160 B5 BN 160MR 4	88
34	2905	1.3	42.8	31000	AS 80 D_160 B5 BN 160MR 4	86
36	2751	2.3	40.6	42000	AS 90 D_160 B5 BN 160MR 4	88
38	2598	1.5	38.3	31000	AS 80 D_160 B5 BN 160MR 4	86
40	2461	2.5	36.3	42000	AS 90 D_160 B5 BN 160MR 4	88
42	2339	1.6	34.5	31000	AS 80 D_160 B5 BN 160MR 4	86
44	2214	2.8	32.6	42000	AS 90 D_160 B5 BN 160MR 4	88
46	2116	1.8	31.2	31000	AS 80 D_160 B5 BN 160MR 4	86
49	2004	3.1	29.5	42000	AS 90 D_160 B5 BN 160MR 4	88
57	1765	1.2	25.47	11700	AS 60_160 B5 BN 160MR 4	84
57	1757	2.2	25.35	31000	AS 80_160 B5 BN 160MR 4	86
63	1579	1.3	22.78	11600	AS 60_160 B5 BN 160MR 4	84
64	1571	2.4	22.67	31000	AS 80_160 B5 BN 160MR 4	86
70	1421	1.5	20.5	11600	AS 60_160 B5 BN 160MR 4	84
71	1414	2.7	20.4	31000	AS 80_160 B5 BN 160MR 4	86
78	1285	1.6	18.55	11500	AS 60_160 B5 BN 160MR 4	84
78	1279	3.0	18.46	31000	AS 80_160 B5 BN 160MR 4	86
79	1269	0.9	18.31	11500	AS 55_160 B5 BN 160MR 4	82
90	1106	1.0	15.96	12000	AS 55_160 B5 BN 160MR 4	82
92	1085	1.8	15.65	11600	AS 60_160 B5 BN 160MR 4	84
92	1085	2.9	15.65	30900	AS 80_160 B5 BN 160MR 4	86
102	979	1.1	14.13	11800	AS 55_160 B5 BN 160MR 4	82
103	970	2.0	14	11400	AS 60_160 B5 BN 160MR 4	84
103	970	3.3	14	30100	AS 80_160 B5 BN 160MR 4	86
114	873	1.3	12.6	11700	AS 55_160 B5 BN 160MR 4	82
114	873	2.2	12.6	11300	AS 60_160 B5 BN 160MR 4	84
126	790	2.4	11.4	11100	AS 60_160 B5 BN 160MR 4	84
127	784	1.4	11.31	11500	AS 55_160 B5 BN 160MR 4	82
140	715	1.5	10.31	11700	AS 55_160 B5 BN 160MR 4	82
142	701	2.7	10.12	11100	AS 60_160 B5 BN 160MR 4	84
157	636	3.3	18.55	10800	AS 60_160 B5 BN 160MR 2	84
158	633	1.7	9.13	11500	AS 55_160 B5 BN 160MR 4	82
159	628	1.9	18.31	11300	AS 55_160 B5 BN 160MR 2	82
159	627	3.0	9.05	10800	AS 60_160 B5 BN 160MR 4	84
177	564	1.9	8.14	11200	AS 55_160 B5 BN 160MR 4	82
177	564	3.4	8.14	10600	AS 60_160 B5 BN 160MR 4	84
182	547	1.8	15.96	11300	AS 55_160 B5 BN 160MR 2	82
186	537	3.2	15.65	10600	AS 60_160 B5 BN 160MR 2	84
197	506	2.2	7.31	11000	AS 55_160 B5 BN 160MR 4	82
206	484	2.1	14.13	11000	AS 55_160 B5 BN 160MR 2	82
224	445	1.8	6.42	10900	AS 55_160 B5 BN 160MR 4	82
231	432	2.3	12.6	10800	AS 55_160 B5 BN 160MR 2	82
241	413	3.4	5.96	10100	AS 60_160 B5 BN 160MR 4	84
253	394	2.0	5.68	10700	AS 55_160 B5 BN 160MR 4	82
257	388	2.6	11.31	10600	AS 55_160 B5 BN 160MR 2	82
282	354	2.5	10.31	10500	AS 55_160 B5 BN 160MR 2	82
284	351	2.3	5.07	10400	AS 55_160 B5 BN 160MR 4	82
317	315	2.5	4.55	10200	AS 55_160 B5 BN 160MR 4	82
319	313	2.9	9.13	10200	AS 55_160 B5 BN 160MR 2	82
357	279	3.2	8.14	10000	AS 55_160 B5 BN 160MR 2	82
453	220	2.9	6.42	9550	AS 55_160 B5 BN 160MR 2	82
512	195	3.3	5.68	9270	AS 55_160 B5 BN 160MR 2	82



15 kW

n_2 min ⁻¹	M_2 Nm	S	i	Rn_2 N			
21.2	6277	1.0	68.8	42000	AS 90 D_160 B5	BN 160L 4	88
23.7	5614	1.1	61.5	42000	AS 90 D_160 B5	BN 160L 4	88
26.4	5053	1.2	55.4	42000	AS 90 D_160 B5	BN 160L 4	88
29.1	4571	1.4	50.1	42000	AS 90 D_160 B5	BN 160L 4	88
34	3908	1.0	42.8	31000	AS 80 D_160 B5	BN 160L 4	86
36	3700	1.7	40.6	42000	AS 90 D_160 B5	BN 160L 4	88
38	3495	1.1	38.3	31000	AS 80 D_160 B5	BN 160L 4	86
40	3309	1.9	36.3	42000	AS 90 D_160 B5	BN 160L 4	88
42	3145	1.2	34.5	31000	AS 80 D_160 B5	BN 160L 4	86
45	2978	2.1	32.6	42000	AS 90 D_160 B5	BN 160L 4	88
47	2846	1.3	31.2	31000	AS 80 D_160 B5	BN 160L 4	86
49	2695	2.3	29.5	42000	AS 90 D_160 B5	BN 160L 4	88
58	2362	1.6	25.35	31000	AS 80_160 B5	BN 160L 4	86
64	2123	1.0	22.78	9680	AS 60_160 B5	BN 160L 4	84
64	2113	1.8	22.67	31000	AS 80_160 B5	BN 160L 4	86
71	1911	1.1	20.5	9760	AS 60_160 B5	BN 160L 4	84
72	1901	2.0	20.4	30500	AS 80_160 B5	BN 160L 4	86
79	1729	1.2	18.55	9790	AS 60_160 B5	BN 160L 4	84
79	1720	2.2	18.46	29900	AS 80_160 B5	BN 160L 4	86
93	1459	1.3	15.65	10300	AS 60_160 B5	BN 160L 4	84
93	1459	2.2	15.65	29500	AS 80_160 B5	BN 160L 4	86
104	1305	1.5	14	10200	AS 60_160 B5	BN 160L 4	84
104	1305	2.5	14	28800	AS 80_160 B5	BN 160L 4	86
116	1174	0.9	12.6	10200	AS 55_160 B5	BN 160L 4	82
116	1174	1.6	12.6	10100	AS 60_160 B5	BN 160L 4	84
116	1174	2.7	12.6	28100	AS 80_160 B5	BN 160L 4	86
128	1063	1.8	11.4	10000	AS 60_160 B5	BN 160L 4	84
128	1063	3.0	11.4	27400	AS 80_160 B5	BN 160L 4	86
129	1054	1.0	11.31	10100	AS 55_160 B5	BN 160L 4	82
142	961	1.1	10.31	10500	AS 55_160 B5	BN 160L 4	82
144	943	2.0	10.12	10200	AS 60_160 B5	BN 160L 4	84
158	861	2.4	18.55	9950	AS 60_160 B5	BN 160MB 2	84
160	851	1.3	9.13	10400	AS 55_160 B5	BN 160L 4	82
160	850	1.4	18.31	10200	AS 55_160 B5	BN 160MB 2	82
161	843	2.3	9.05	10000	AS 60_160 B5	BN 160L 4	84
179	759	1.4	8.14	10200	AS 55_160 B5	BN 160L 4	82
179	759	2.5	8.14	9890	AS 60_160 B5	BN 160L 4	84
184	741	1.3	15.96	10400	AS 55_160 B5	BN 160MB 2	82
187	727	2.3	15.65	9950	AS 60_160 B5	BN 160MB 2	84
198	687	2.8	7.37	9730	AS 60_160 B5	BN 160L 4	84
200	681	1.6	7.31	10100	AS 55_160 B5	BN 160L 4	82
207	656	1.5	14.13	10200	AS 55_160 B5	BN 160MB 2	82
209	650	2.6	14	9760	AS 60_160 B5	BN 160MB 2	84
227	598	1.3	6.42	10200	AS 55_160 B5	BN 160L 4	82
233	585	1.7	12.6	10000	AS 55_160 B5	BN 160MB 2	82
233	585	2.9	12.6	9570	AS 60_160 B5	BN 160MB 2	84
245	556	2.5	5.96	9580	AS 60_160 B5	BN 160L 4	84
257	530	1.5	5.68	10000	AS 55_160 B5	BN 160L 4	82
257	529	3.2	11.4	9390	AS 60_160 B5	BN 160MB 2	84
259	525	1.9	11.31	9890	AS 55_160 B5	BN 160MB 2	82
274	497	2.8	5.33	9370	AS 60_160 B5	BN 160L 4	84
284	479	1.9	10.31	9940	AS 55_160 B5	BN 160MB 2	82
288	472	1.7	5.07	9810	AS 55_160 B5	BN 160L 4	82
290	470	3.2	10.12	9310	AS 60_160 B5	BN 160MB 2	84
304	447	3.1	4.8	9170	AS 60_160 B5	BN 160L 4	84
321	424	2.1	9.13	9710	AS 55_160 B5	BN 160MB 2	82
321	424	1.9	4.55	9610	AS 55_160 B5	BN 160L 4	82
336	405	3.5	4.34	8970	AS 60_160 B5	BN 160L 4	84
360	378	2.4	8.14	9490	AS 55_160 B5	BN 160MB 2	82
401	339	2.7	7.31	9280	AS 55_160 B5	BN 160MB 2	82

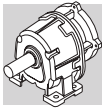

15 kW

n_2 min ⁻¹	M_2 Nm	S	i	Rn_2 N	IEC	
456	298	2.1	6.42	9160	AS 55_ 160 B5 BN 160MB 2	82
516	264	2.4	5.68	8920	AS 55_ 160 B5 BN 160MB 2	82
578	235	2.7	5.07	8680	AS 55_ 160 B5 BN 160MB 2	82
644	211	3.0	4.55	8460	AS 55_ 160 B5 BN 160MB 2	82

18.5 kW

26.4	6231	1.0	55.4	42000	AS 90 D_ 180 B5 BN 180M 4	88
29.1	5638	1.1	50.1	42000	AS 90 D_ 180 B5 BN 180M 4	88
36	4564	1.4	40.6	42000	AS 90 D_ 180 B5 BN 180M 4	88
40	4081	1.5	36.3	42000	AS 90 D_ 180 B5 BN 180M 4	88
45	3673	1.7	32.6	42000	AS 90 D_ 180 B5 BN 180M 4	88
49	3323	1.9	29.5	42000	AS 90 D_ 180 B5 BN 180M 4	88
58	2914	1.3	25.35	29700	AS 80_ 180 B5 BN 180M 4	86
58	2914	2.1	25.35	42000	AS 90_ 180 B5 BN 180M 4	88
64	2606	1.5	22.67	29300	AS 80_ 180 B5 BN 180M 4	86
64	2606	2.4	22.67	42000	AS 90_ 180 B5 BN 180M 4	88
72	2345	1.6	20.4	28800	AS 80_ 180 B5 BN 180M 4	86
72	2345	2.6	20.4	41200	AS 90_ 180 B5 BN 180M 4	88
79	2132	1.0	18.55	8290	AS 60_ 180 B5 BN 180M 4	84
79	2122	1.8	18.46	28400	AS 80_ 180 B5 BN 180M 4	86
79	2122	2.9	18.46	40300	AS 90_ 180 B5 BN 180M 4	88
93	1800	1.1	15.65	9120	AS 60_ 180 B5 BN 180M 4	84
93	1800	1.8	15.65	28300	AS 80_ 180 B5 BN 180M 4	86
93	1800	2.9	15.65	39200	AS 90_ 180 B5 BN 180M 4	88
104	1609	1.2	14	9160	AS 60_ 180 B5 BN 180M 4	84
104	1609	2.0	14	27700	AS 80_ 180 B5 BN 180M 4	86
104	1609	3.3	14	38200	AS 90_ 180 B5 BN 180M 4	88
116	1448	1.3	12.6	9160	AS 60_ 180 B5 BN 180M 4	84
116	1448	2.2	12.6	27100	AS 80_ 180 B5 BN 180M 4	86
128	1311	1.4	11.4	9140	AS 60_ 180 B5 BN 180M 4	84
128	1311	2.4	11.4	26500	AS 80_ 180 B5 BN 180M 4	86
144	1163	1.6	10.12	9450	AS 60_ 180 B5 BN 180M 4	84
144	1163	2.8	10.12	26200	AS 80_ 180 B5 BN 180M 4	86
158	1062	2.0	18.55	9200	AS 60_ 160 B5 BN 160L 2	84
160	1049	1.1	18.31	9220	AS 55_ 160 B5 BN 160L 2	82
161	1040	1.8	9.05	9360	AS 60_ 180 B5 BN 180M 4	84
161	1040	3.1	9.05	25600	AS 80_ 180 B5 BN 180M 4	86
179	936	2.0	8.14	9250	AS 60_ 180 B5 BN 180M 4	84
179	936	3.4	8.14	25000	AS 80_ 180 B5 BN 180M 4	86
184	914	1.1	15.96	9610	AS 55_ 160 B5 BN 160L 2	82
187	897	1.9	15.65	9360	AS 60_ 160 B5 BN 160L 2	84
187	897	3.2	15.65	24900	AS 80_ 160 B5 BN 160L 2	86
198	847	2.2	7.37	9140	AS 60_ 180 B5 BN 180M 4	84
207	809	1.2	14.13	9520	AS 55_ 160 B5 BN 160L 2	82
209	802	2.1	14	9220	AS 60_ 160 B5 BN 160L 2	84
233	722	1.4	12.6	9400	AS 55_ 160 B5 BN 160L 2	82
233	722	2.4	12.6	9080	AS 60_ 160 B5 BN 160L 2	84
245	686	2.0	5.96	9130	AS 60_ 180 B5 BN 180M 4	84
257	653	2.6	11.4	8930	AS 60_ 160 B5 BN 160L 2	84
259	648	1.5	11.31	9280	AS 55_ 160 B5 BN 160L 2	82
274	613	2.3	5.33	8960	AS 60_ 180 B5 BN 180M 4	84
284	591	1.5	10.31	9420	AS 55_ 160 B5 BN 160L 2	82
290	580	2.6	10.12	8930	AS 60_ 160 B5 BN 160L 2	84
304	552	2.5	4.8	8790	AS 60_ 180 B5 BN 180M 4	84
321	523	1.7	9.13	9240	AS 55_ 160 B5 BN 160L 2	82
324	518	2.9	9.05	8750	AS 60_ 160 B5 BN 160L 2	84
336	499	2.8	4.34	8620	AS 60_ 180 B5 BN 180M 4	84

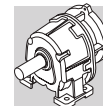

18.5 kW

n_2 min ⁻¹	M_2 Nm	S	i	Rn_2 N	IEC	
360	466	1.9	8.14	9060	AS 55_ 160 B5 BN 160L 2	82
360	466	3.2	8.14	8570	AS 60_ 160 B5 BN 160L 2	84
401	419	2.1	7.31	8880	AS 55_ 160 B5 BN 160L 2	82
456	368	1.7	6.42	8840	AS 55_ 160 B5 BN 160L 2	82
491	342	3.2	5.96	8160	AS 60_ 160 B5 BN 160L 2	84
516	326	2.0	5.68	8620	AS 55_ 160 B5 BN 160L 2	82
578	290	2.2	5.07	8420	AS 55_ 160 B5 BN 160L 2	82
644	261	2.5	4.55	8220	AS 55_ 160 B5 BN 160L 2	82

22 kW

29.3	6659	0.9	50.1	42000	AS 90 D_ 180 B5 BN 180L 4	88
36	5390	1.2	40.6	42000	AS 90 D_ 180 B5 BN 180L 4	88
41	4821	1.3	36.3	42000	AS 90 D_ 180 B5 BN 180L 4	88
45	4339	1.4	32.6	42000	AS 90 D_ 180 B5 BN 180L 4	88
50	3925	1.6	29.5	42000	AS 90 D_ 180 B5 BN 180L 4	88
58	3441	1.1	25.35	27800	AS 80_ 180 B5 BN 180L 4	86
58	3441	1.8	25.35	41700	AS 90_ 180 B5 BN 180L 4	88
65	3078	1.2	22.67	27500	AS 80_ 180 B5 BN 180L 4	86
65	3078	2.0	22.67	40800	AS 90_ 180 B5 BN 180L 4	88
72	2770	1.4	20.4	27200	AS 80_ 180 B5 BN 180L 4	86
72	2770	2.2	20.4	39900	AS 90_ 180 B5 BN 180L 4	88
80	2506	1.5	18.46	26800	AS 80_ 180 B5 BN 180L 4	86
80	2506	2.5	18.46	39100	AS 90_ 180 B5 BN 180L 4	88
94	2126	1.5	15.65	27000	AS 80_ 180 B5 BN 180L 4	86
94	2126	2.5	15.65	38300	AS 90_ 180 B5 BN 180L 4	88
105	1901	1.0	14	8100	AS 60_ 180 B5 BN 180L 4	84
105	1901	1.7	14	26500	AS 80_ 180 B5 BN 180L 4	86
105	1901	2.8	14	37300	AS 90_ 180 B5 BN 180L 4	88
117	1711	1.1	12.6	8180	AS 60_ 180 B5 BN 180L 4	84
117	1711	1.9	12.6	26000	AS 80_ 180 B5 BN 180L 4	86
117	1711	3.1	12.6	36400	AS 90_ 180 B5 BN 180L 4	88
129	1548	1.2	11.4	8230	AS 60_ 180 B5 BN 180L 4	84
129	1548	2.1	11.4	25600	AS 80_ 180 B5 BN 180L 4	86
129	1548	3.4	11.4	35500	AS 90_ 180 B5 BN 180L 4	88
145	1374	1.4	10.12	8690	AS 60_ 180 B5 BN 180L 4	84
145	1374	2.3	10.12	25400	AS 80_ 180 B5 BN 180L 4	86
158	1263	1.7	18.55	8460	AS 60_ 180 B5 BN 180M 2	84
159	1257	3.0	18.46	24700	AS 80_ 180 B5 BN 180M 2	86
162	1228	1.5	9.05	8660	AS 60_ 180 B5 BN 180L 4	84
162	1228	2.6	9.05	24900	AS 80_ 180 B5 BN 180L 4	86
181	1106	1.7	8.14	8610	AS 60_ 180 B5 BN 180L 4	84
181	1106	2.9	8.14	24300	AS 80_ 180 B5 BN 180L 4	86
187	1066	1.6	15.65	8770	AS 60_ 180 B5 BN 180M 2	84
187	1066	2.7	15.65	24300	AS 80_ 180 B5 BN 180M 2	86
200	1000	1.9	7.37	8540	AS 60_ 180 B5 BN 180L 4	84
200	1000	3.2	7.37	23800	AS 80_ 180 B5 BN 180L 4	86
209	954	1.8	14	8690	AS 60_ 180 B5 BN 180M 2	84
209	954	3.0	14	23700	AS 80_ 180 B5 BN 180M 2	86
233	858	2.0	12.6	8590	AS 60_ 180 B5 BN 180M 2	84
233	858	3.4	12.6	23100	AS 80_ 180 B5 BN 180M 2	86
246	810	1.7	5.96	8670	AS 60_ 180 B5 BN 180L 4	84
246	810	3.0	5.96	23000	AS 80_ 180 B5 BN 180L 4	86
257	777	2.2	11.4	8480	AS 60_ 180 B5 BN 180M 2	84
276	724	1.9	5.33	8540	AS 60_ 180 B5 BN 180L 4	84
276	724	3.3	5.33	22400	AS 80_ 180 B5 BN 180L 4	86
290	689	2.2	10.12	8550	AS 60_ 180 B5 BN 180M 2	84
306	652	2.1	4.8	8410	AS 60_ 180 B5 BN 180L 4	84

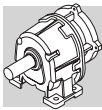

22 kW

n_2 min ⁻¹	M_2 Nm	S	i	Rn_2 N	IEC		
324	616	2.4	9.05	8400	AS 60_ 180 B5	BN 180M 2	84
338	590	2.4	4.34	8270	AS 60_ 180 B5	BN 180L 4	84
360	555	2.7	8.14	8250	AS 60_ 180 B5	BN 180M 2	84
398	502	3.0	7.37	8100	AS 60_ 180 B5	BN 180M 2	84
491	406	2.7	5.96	7930	AS 60_ 180 B5	BN 180M 2	84
549	363	3.0	5.33	7750	AS 60_ 180 B5	BN 180M 2	84
610	327	3.4	4.8	7570	AS 60_ 180 B5	BN 180M 2	84

30 kW

58	4693	1.3	25.35	38500	AS 90_ 200 B5	BN 200L 4	88
65	4197	0.9	22.67	23400	AS 80_ 200 B5	BN 200L 4	86
65	4197	1.5	22.67	37800	AS 90_ 200 B5	BN 200L 4	88
72	3777	1.0	20.4	23500	AS 80_ 200 B5	BN 200L 4	86
72	3777	1.6	20.4	37200	AS 90_ 200 B5	BN 200L 4	88
80	3417	1.1	18.46	23400	AS 80_ 200 B5	BN 200L 4	86
80	3417	1.8	18.46	36600	AS 90_ 200 B5	BN 200L 4	88
94	2898	1.1	15.65	24300	AS 80_ 200 B5	BN 200L 4	86
94	2898	1.8	15.65	36300	AS 90_ 200 B5	BN 200L 4	88
105	2592	1.2	14	24000	AS 80_ 200 B5	BN 200L 4	86
105	2592	2.0	14	35500	AS 90_ 200 B5	BN 200L 4	88
117	2333	1.4	12.6	23800	AS 80_ 200 B5	BN 200L 4	86
117	2333	2.3	12.6	34700	AS 90_ 200 B5	BN 200L 4	88
129	2111	1.5	11.4	23400	AS 80_ 200 B5	BN 200L 4	86
129	2111	2.5	11.4	34000	AS 90_ 200 B5	BN 200L 4	88
145	1873	1.7	10.12	23700	AS 80_ 200 B5	BN 200L 4	86
145	1873	2.8	10.12	33600	AS 90_ 200 B5	BN 200L 4	88
160	1703	2.2	18.46	23000	AS 80_ 200 B5	BN 200LA 2	86
162	1675	1.9	9.05	23200	AS 80_ 200 B5	BN 200L 4	86
162	1675	3.2	9.05	32700	AS 90_ 200 B5	BN 200L 4	88
181	1508	2.1	8.14	22800	AS 80_ 200 B5	BN 200L 4	86
188	1444	2.0	15.65	22900	AS 80_ 200 B5	BN 200LA 2	86
188	1444	3.3	15.65	31800	AS 90_ 200 B5	BN 200LA 2	88
200	1364	2.3	7.37	22400	AS 80_ 200 B5	BN 200L 4	86
211	1292	2.2	14	22400	AS 80_ 200 B5	BN 200LA 2	86
234	1163	2.5	12.6	22000	AS 80_ 200 B5	BN 200LA 2	86
246	1104	2.2	5.96	21900	AS 80_ 200 B5	BN 200L 4	86
259	1052	2.8	11.4	21500	AS 80_ 200 B5	BN 200LA 2	86
276	987	2.4	5.33	21400	AS 80_ 200 B5	BN 200L 4	86
292	933	2.8	10.12	21300	AS 80_ 200 B5	BN 200LA 2	86
306	889	2.7	4.8	20900	AS 80_ 200 B5	BN 200L 4	86
326	835	3.1	9.05	20700	AS 80_ 200 B5	BN 200LA 2	86
338	804	3.0	4.34	20500	AS 80_ 200 B5	BN 200L 4	86
362	751	3.5	8.14	20200	AS 80_ 200 B5	BN 200LA 2	86
495	550	3.5	5.96	19000	AS 80_ 200 B5	BN 200LA 2	86

37 kW

58	5749	1.1	25.35	35600	AS 90_ 225 B5	BN 225S 4	88
65	5141	1.2	22.67	35300	AS 90_ 225 B5	BN 225S 4	88
73	4627	1.3	20.4	34800	AS 90_ 225 B5	BN 225S 4	88
80	4186	1.5	18.46	34400	AS 90_ 225 B5	BN 225S 4	88
95	3551	1.5	15.65	34500	AS 90_ 225 B5	BN 225S 4	88
106	3175	1.0	14	21900	AS 80_ 225 B5	BN 225S 4	86
106	3175	1.7	14	33900	AS 90_ 225 B5	BN 225S 4	88
117	2858	1.9	12.6	33200	AS 90_ 225 B5	BN 225S 4	88
130	2586	2.0	11.4	32600	AS 90_ 225 B5	BN 225S 4	88

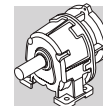

37 kW

n_2 min ⁻¹	M_2 Nm	S	i	Rn_2 N	IEC	
146	2295	2.3	10.12	32400	AS 90_ 225 B5 BN 225S 4	88
160	2093	1.8	18.46	21500	AS 80_ 200 B5 BN 200LB 2	86
160	2093	3.0	18.46	31500	AS 90_ 200 B5 BN 200LB 2	88
164	2052	2.6	9.05	31600	AS 90_ 225 B5 BN 225S 4	88
182	1847	2.9	8.14	30900	AS 90_ 225 B5 BN 225S 4	88
189	1775	1.6	15.65	21700	AS 80_ 200 B5 BN 200LB 2	86
189	1775	2.6	15.65	30900	AS 90_ 200 B5 BN 200LB 2	88
201	1671	3.2	7.37	30200	AS 90_ 225 B5 BN 225S 4	88
211	1588	1.8	14	21300	AS 80_ 200 B5 BN 200LB 2	86
211	1588	3.0	14	30100	AS 90_ 200 B5 BN 200LB 2	88
235	1429	2.0	12.6	20900	AS 80_ 200 B5 BN 200LB 2	86
235	1429	3.3	12.6	29400	AS 90_ 200 B5 BN 200LB 2	88
248	1353	3.0	5.96	29200	AS 90_ 225 B5 BN 225S 4	88
260	1293	2.2	11.4	20600	AS 80_ 200 B5 BN 200LB 2	86
278	1210	3.4	5.33	28400	AS 90_ 225 B5 BN 225S 4	88
293	1147	2.3	10.12	20500	AS 80_ 200 B5 BN 200LB 2	86
327	1026	2.5	9.05	20000	AS 80_ 200 B5 BN 200LB 2	86
364	923	2.8	8.14	19600	AS 80_ 200 B5 BN 200LB 2	86
402	836	3.1	7.37	19200	AS 80_ 200 B5 BN 200LB 2	86
496	676	2.8	5.96	18500	AS 80_ 200 B5 BN 200LB 2	86
555	605	3.1	5.33	18100	AS 80_ 200 B5 BN 200LB 2	86
617	544	3.5	4.8	17600	AS 80_ 200 B5 BN 200LB 2	86

45 kW

65	6253	1.0	22.67	27000	AS 90_ 225 B5 BN 225M 4	88
73	5627	1.1	20.4	29400	AS 90_ 225 B5 BN 225M 4	88
80	5091	1.2	18.46	31200	AS 90_ 225 B5 BN 225M 4	88
95	4318	1.2	15.65	32500	AS 90_ 225 B5 BN 225M 4	88
106	3862	1.4	14	32100	AS 90_ 225 B5 BN 225M 4	88
117	3476	1.5	12.6	31600	AS 90_ 225 B5 BN 225M 4	88
130	3145	1.7	11.4	31100	AS 90_ 225 B5 BN 225M 4	88
146	2791	1.9	10.12	31100	AS 90_ 225 B5 BN 225M 4	88
160	2546	2.4	18.46	30300	AS 90_ 225 B5 BN 225M 2	88
164	2496	2.1	9.05	30500	AS 90_ 225 B5 BN 225M 4	88
182	2246	2.4	8.14	29800	AS 90_ 225 B5 BN 225M 4	88
189	2159	2.2	15.65	29900	AS 90_ 225 B5 BN 225M 2	88
201	2032	2.6	7.37	29200	AS 90_ 225 B5 BN 225M 4	88
211	1931	1.5	14	20100	AS 80_ 225 B5 BN 225M 2	86
211	1931	2.4	14	29200	AS 90_ 225 B5 BN 225M 2	88
235	1738	2.7	12.6	28600	AS 90_ 225 B5 BN 225M 2	88
248	1645	2.5	5.96	28400	AS 90_ 225 B5 BN 225M 4	88
260	1572	3.0	11.4	27900	AS 90_ 225 B5 BN 225M 2	88
278	1471	2.8	5.33	27700	AS 90_ 225 B5 BN 225M 4	88
293	1395	3.1	10.12	27500	AS 90_ 225 B5 BN 225M 2	88
308	1324	3.1	4.8	27100	AS 90_ 225 B5 BN 225M 4	88
327	1248	3.4	9.05	26800	AS 90_ 225 B5 BN 225M 2	88
341	1198	3.4	4.34	26400	AS 90_ 225 B5 BN 225M 4	88

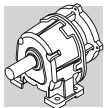

AS 16



50 Nm

23 - TABELLE DATI TECNICI
RIDUTTORI



23 - SPEED REDUCER RATING
CHARTS

23 - GETRIEBE
AUSWAHLTABELLEN

23 - DONNEES TECHNIQUES
REDUCTEURS

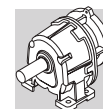
	i	$n_1 = 2800 \text{ min}^{-1}$					$n_1 = 1400 \text{ min}^{-1}$					
		n_2 min^{-1}	M_{n2} Nm	P_{n1} kW	R_{n1} N	R_{n2} N	n_2 min^{-1}	M_{n2} Nm	P_{n1} kW	R_{n1} N	R_{n2} N	
AS 16_	5.53	506	25	1.4	330	290	253	30	0.84	330	380	71
AS 16_	6.68	419	25	1.2	330	330	210	30	0.69	330	430	
AS 16_	7.41	378	25	1.0	330	350	189	30	0.62	330	460	
AS 16_	9.31	301	25	0.83	330	390	150	30	0.50	330	500	
AS 16_	11.24	249	35	0.96	330	340	125	40	0.55	330	470	
AS 16_	12.47	225	35	0.87	330	368	112	40	0.49	330	500	
AS 16_	15.64	179	35	0.69	330	410	90	40	0.39	330	550	
AS 16_	18.89	148	35	0.57	330	470	74	40	0.33	330	630	
AS 16_	20.96	134	45	0.66	330	410	67	45	0.33	330	620	
AS 16_	27.14	103	45	0.51	330	460	52	45	0.26	330	700	
AS 16_	32.78	85	45	0.42	330	530	43	45	0.21	330	780	
AS 16_	36.36	77	45	0.38	330	570	39	45	0.19	330	830	
AS 16_	40.32	69	45	0.34	330	600	35	45	0.17	330	870	
AS 16_	44.73	63	45	0.31	330	640	31	45	0.16	330	920	
$n_1 = 900 \text{ min}^{-1}$						$n_1 = 500 \text{ min}^{-1}$						
AS 16_	5.53	163	45	0.81	330	340	90	50	0.50	330	450	71
AS 16_	6.68	135	45	0.67	330	400	75	50	0.41	330	530	
AS 16_	7.41	121	45	0.60	330	430	67	50	0.37	330	570	
AS 16_	9.31	97	45	0.48	330	480	54	50	0.30	330	630	
AS 16_	11.24	80	45	0.40	330	550	44	50	0.24	330	720	
AS 16_	12.47	72	45	0.36	330	590	40	50	0.22	330	770	
AS 16_	15.64	58	45	0.29	330	660	32	50	0.18	330	840	
AS 16_	18.89	48	45	0.24	330	740	26	50	0.15	330	940	
AS 16_	20.96	43	45	0.21	330	790	24	50	0.13	330	1000	
AS 16_	27.14	33	45	0.16	330	870	18	50	0.10	330	1110	
AS 16_	32.78	27	45	0.14	330	970	15	50	0.08	330	1230	
AS 16_	36.36	25	45	0.12	330	1030	14	50	0.08	330	1290	
AS 16_	40.32	22	45	0.11	330	1070	12	50	0.07	330	1350	
AS 16_	44.73	20	45	0.10	330	1130	11	50	0.06	330	1420	



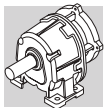

	i	$n_1 = 2800 \text{ min}^{-1}$					$n_1 = 1400 \text{ min}^{-1}$					
		n_2 min^{-1}	M_{n2} Nm	P_{n1} kW	R_{n1} N	R_{n2} N	n_2 min^{-1}	M_{n2} Nm	P_{n1} kW	R_{n1} N	R_{n2} N	
AS 20_	5.49	510	50	2.8	600	730	255	60	1.7	600	950	73
AS 20_	6.46	433	50	2.4	600	800	217	60	1.4	600	1040	
AS 20_	7.75	361	50	2.0	600	890	181	60	1.2	600	1150	
AS 20_	8.57	327	50	1.8	600	940	163	60	1.1	600	1210	
AS 20_	9.92	282	55	1.7	600	940	141	65	1.0	600	1220	
AS 20_	11.67	240	55	1.5	600	1030	120	65	0.86	600	1340	
AS 20_	14	200	55	1.2	600	1140	100	65	0.72	600	1470	
AS 20_	15.48	181	55	1.1	600	1200	90	65	0.65	600	1540	
AS 20_	18.01	155	80	1.4	600	1040	78	80	0.68	600	1490	
AS 20_	21.19	132	80	1.2	600	1150	66	80	0.58	600	1620	
AS 20_	25.43	110	80	0.97	600	1280	55	80	0.48	600	1780	
AS 20_	28.13	100	80	0.88	600	1350	50	80	0.44	600	1880	
AS 20_	31.71	88	80	0.78	600	1390	44	80	0.39	600	1940	
AS 20_	37.31	75	80	0.66	600	1530	38	80	0.33	600	2100	
AS 20_	44.77	63	80	0.55	600	1680	31	80	0.28	600	2290	
AS 20_	49.52	57	80	0.50	600	1770	28.3	80	0.25	600	2400	
AS 20 D_	58.1	48	90	0.49	330	1810	24.1	90	0.24	330	2476	
AS 20 D_	64.3	44	90	0.44	330	1910	21.8	90	0.22	330	2595	
AS 20 D_	69.2	40	90	0.41	330	1930	20.2	90	0.21	330	2632	
AS 20 D_	81.4	34	90	0.35	330	2100	17.2	90	0.17	330	2800	
AS 20 D_	97.7	28.7	90	0.29	330	2300	14.3	90	0.15	330	2800	
AS 20 D_	108.1	25.9	90	0.26	330	2410	13.0	90	0.13	330	2800	
AS 20 D_	120.1	23.3	90	0.24	330	2470	11.7	90	0.12	330	2800	
AS 20 D_	141.3	19.8	90	0.20	330	2680	9.9	90	0.10	330	2800	
AS 20 D_	169.5	16.5	90	0.17	330	2800	8.3	90	0.08	330	2800	
AS 20 D_	187.5	14.9	90	0.15	330	2800	7.5	90	0.08	330	2800	

$n_1 = 900 \text{ min}^{-1}$							$n_1 = 500 \text{ min}^{-1}$					
AS 20_	i	n_2 min^{-1}	M_{n2} Nm	P_{n1} kW	R_{n1} N	R_{n2} N	n_2 min^{-1}	M_{n2} Nm	P_{n1} kW	R_{n1} N	R_{n2} N	
AS 20_	5.49	164	90	1.6	600	920	91	100	1.0	600	1200	73
AS 20_	6.46	139	90	1.4	600	1030	77	100	0.85	600	1340	
AS 20_	7.75	116	90	1.2	600	1160	65	100	0.71	600	1490	
AS 20_	8.57	105	90	1.0	600	1240	58	100	0.64	600	1580	
AS 20_	9.92	91	90	0.90	600	1290	50	100	0.55	600	1650	
AS 20_	11.67	77	90	0.76	600	1420	43	100	0.47	600	1810	
AS 20_	14.0	64	90	0.64	600	1580	36	100	0.39	600	2000	
AS 20_	15.48	58	90	0.58	600	1670	32	100	0.36	600	2100	
AS 20_	18.01	50	90	0.50	600	1740	27.8	100	0.31	600	2200	
AS 20_	21.19	42	90	0.42	600	1900	23.6	100	0.26	600	2400	
AS 20_	25.43	35	90	0.35	600	2090	19.7	100	0.22	600	2620	
AS 20_	28.13	32	90	0.32	600	2190	17.8	100	0.20	600	2750	
AS 20_	31.71	28.4	90	0.28	600	2270	15.8	100	0.17	600	2800	
AS 20_	37.31	24.1	90	0.24	600	2460	13.4	100	0.15	600	2800	
AS 20_	44.77	20.1	90	0.20	600	2680	11.2	100	0.12	600	2800	
AS 20_	49.52	18.2	90	0.18	600	2800	10.1	100	0.11	600	2800	
AS 20 D_	58.1	15.5	100	0.17	330	2800	8.6	100	0.10	330	2800	
AS 20 D_	64.3	14.0	100	0.16	330	2800	7.8	100	0.09	330	2800	
AS 20 D_	69.2	13.0	100	0.15	330	2800	7.2	100	0.08	330	2800	
AS 20 D_	81.4	11.1	100	0.12	330	2800	6.1	100	0.07	330	2800	
AS 20 D_	97.7	9.2	100	0.10	330	2800	5.1	100	0.06	330	2800	
AS 20 D_	108.1	8.3	100	0.09	330	2800	4.6	100	0.05	330	2800	
AS 20 D_	120.1	7.5	100	0.08	330	2800	4.2	100	0.05	330	2800	
AS 20 D_	141.3	6.4	100	0.07	330	2800	3.5	100	0.04	330	2800	
AS 20 D_	169.5	5.3	100	0.06	330	2800	2.9	100	0.03	330	2800	
AS 20 D_	187.5	4.8	100	0.05	330	2800	2.7	100	0.03	330	2800	





AS 25

200 Nm

	i	$n_1 = 2800 \text{ min}^{-1}$					$n_1 = 1400 \text{ min}^{-1}$					
		n_2 min^{-1}	M_{n2} Nm	P_{n1} kW	R_{n1} N	R_{n2} N	n_2 min^{-1}	M_{n2} Nm	P_{n1} kW	R_{n1} N	R_{n2} N	
AS 25_	5.02	558	80	4.9	370	660	279	120	3.7	350	760	75
AS 25_	5.92	473	90	4.7	410	670	236	120	3.1	450	800	
AS 25_	6.47	433	90	4.3	490	720	216	120	2.9	560	860	
AS 25_	7.88	355	100	3.9	570	760	178	120	2.3	760	1000	
AS 25_	8.93	314	100	3.5	380	780	157	130	2.2	440	950	
AS 25_	10.53	266	100	2.9	520	880	133	130	1.9	630	1080	
AS 25_	11.51	243	110	2.9	520	860	122	130	1.7	720	1150	
AS 25_	14.01	200	110	2.4	670	1000	100	130	1.4	830	1310	
AS 25_	16.42	171	140	2.6	200	820	85	160	1.5	380	1150	
AS 25_	19.35	145	150	2.4	300	880	72	160	1.3	580	1320	
AS 25_	21.16	132	150	2.2	390	950	66	160	1.2	670	1400	
AS 25_	25.75	109	160	1.9	510	1040	54	160	0.96	830	1600	
AS 25_	31.27	90	140	1.4	310	1270	45	160	0.79	510	1720	
AS 25_	36.86	76	150	1.3	410	1350	38	160	0.67	690	1910	
AS 25_	40.29	69	160	1.2	430	1360	35	160	0.61	780	2020	
AS 25_	49.04	57	160	1.0	590	1560	28.5	160	0.50	830	2260	
AS 25 D_	60.1	47	180	0.95	500	1607	23.3	180	0.47	500	3200	
AS 25 D_	69.6	40	180	0.82	420	1672	20.1	180	0.41	500	3200	
AS 25 D_	82.0	34	180	0.69	471	1875	17.1	180	0.35	500	3200	
AS 25 D_	89.7	31	180	0.63	496	1987	15.6	180	0.32	500	3200	
AS 25 D_	109.1	25.7	180	0.52	500	2239	12.8	180	0.26	500	3200	
AS 25 D_	122.5	22.9	180	0.46	450	2298	11.4	180	0.23	500	3200	
AS 25 D_	144.4	19.4	180	0.39	497	2537	9.7	180	0.20	500	3200	
AS 25 D_	157.9	17.7	180	0.36	500	2668	8.9	180	0.18	500	3200	
AS 25 D_	192.1	14.6	180	0.30	500	2967	7.3	180	0.15	500	3200	

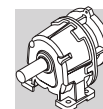
$n_1 = 900 \text{ min}^{-1}$							$n_1 = 500 \text{ min}^{-1}$					
		n_2 min^{-1}	M_{n2} Nm	P_{n1} kW	R_{n1} N	R_{n2} N	n_2 min^{-1}	M_{n2} Nm	P_{n1} kW	R_{n1} N	R_{n2} N	
AS 25_	5.02	179	130	2.6	380	860	100	160	1.8	440	1040	75
AS 25_	5.92	152	150	2.5	410	840	84	190	1.8	420	970	
AS 25_	6.47	139	160	2.5	450	840	77	200	1.7	500	990	
AS 25_	7.88	114	180	2.3	560	860	63	200	1.4	830	1190	
AS 25_	8.93	101	160	1.8	420	1030	56	200	1.2	450	1210	
AS 25_	10.53	85	180	1.7	490	1040	47	200	1.0	750	1400	
AS 25_	11.51	78	180	1.5	610	1120	43	200	0.96	830	1500	
AS 25_	14.01	64	180	1.3	830	1320	36	200	0.79	830	1730	
AS 25_	16.42	55	180	1.1	490	1380	30.5	200	0.67	750	1820	
AS 25_	19.35	47	180	0.92	710	1560	25.8	200	0.57	830	2040	
AS 25_	21.16	43	180	0.84	820	1670	23.6	200	0.52	830	2160	
AS 25_	25.75	35	180	0.69	830	1900	19.4	200	0.43	830	2440	
AS 25_	31.27	28.8	180	0.57	640	2030	16.0	200	0.35	830	2610	
AS 25_	36.86	24.4	180	0.48	830	2250	13.6	200	0.30	830	2880	
AS 25_	40.29	22.3	180	0.44	830	2380	12.4	200	0.27	830	3030	
AS 25_	49.04	18.4	180	0.36	830	2650	10.2	200	0.22	830	3200	
AS 25 D_	60.1	15.0	200	0.34	500	2788	8.3	200	0.19	500	3200	
AS 25 D_	69.6	12.9	200	0.29	500	2910	7.2	200	0.16	500	3200	
AS 25 D_	82.0	11.0	200	0.25	500	3195	6.1	200	0.14	500	3200	
AS 25 D_	89.7	10.0	200	0.23	500	3200	5.6	200	0.13	500	3200	
AS 25 D_	109.1	8.2	200	0.19	500	3200	4.6	200	0.10	500	3200	
AS 25 D_	122.5	7.3	200	0.17	500	3200	4.1	200	0.09	500	3200	
AS 25 D_	144.4	6.2	200	0.14	500	3200	3.5	200	0.08	500	3200	
AS 25 D_	157.9	5.7	200	0.13	500	3200	3.2	200	0.07	500	3200	
AS 25 D_	192.1	4.7	200	0.11	500	3200	2.6	200	0.06	500	3200	



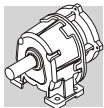

	i	$n_1 = 2800 \text{ min}^{-1}$					$n_1 = 1400 \text{ min}^{-1}$					
		n_2 min^{-1}	M_{n2} Nm	P_{n1} kW	R_{n1} N	R_{n2} N	n_2 min^{-1}	M_{n2} Nm	P_{n1} kW	R_{n1} N	R_{n2} N	
AS 30_	5.11	548	160	9.7	530	1100	274	230	6.9	550	1350	77
AS 30_	6.22	450	180	8.9	710	1200	225	230	5.7	850	1500	
AS 30_	6.93	404	180	8.0	930	1300	202	230	5.1	1000	1600	
AS 30_	7.51	373	180	7.4	590	1300	186	230	4.7	700	1600	
AS 30_	7.78	360	180	7.1	1000	1400	180	230	4.6	1000	1750	
AS 30_	9.14	306	210	7.1	690	1300	153	260	4.4	920	1650	
AS 30_	10.18	275	210	6.4	910	1400	138	260	3.9	1000	1800	
AS 30_	11.43	245	210	5.7	1000	1550	122	260	3.5	1000	2000	
AS 30_	12.62	222	220	5.4	460	1500	111	260	3.2	770	2000	
AS 30_	15.37	182	240	4.8	710	1600	91	260	2.6	1000	2300	
AS 30_	17.11	164	240	4.3	930	1750	82	260	2.3	1000	2500	
AS 30_	19.21	146	240	3.9	1000	1900	73	260	2.1	1000	2600	
AS 30_	24.19	116	250	3.2	430	2000	58	320	2.0	490	2500	
AS 30_	29.45	95	300	3.1	460	2000	48	320	1.7	1000	2800	
AS 30_	32.8	85	320	3.0	560	2000	43	320	1.5	1000	3050	
AS 30_	36.82	76	320	2.7	810	2200	38	320	1.3	1000	3300	
AS 30 D_	41.2	68	320	2.5	660	2350	34	320	1.2	660	3500	
AS 30 D_	46.2	61	320	2.2	660	2550	30	320	1.1	660	3700	
AS 30 D_	54.0	52	320	1.9	660	2650	25.9	320	0.94	660	3900	
AS 30 D_	65.8	43	320	1.5	660	3050	21.3	320	0.77	660	4300	
AS 30 D_	73.6	38	320	1.4	660	3250	19.0	320	0.69	660	4600	
AS 30 D_	82.2	34	320	1.2	660	3500	17.0	320	0.62	660	4860	
AS 30 D_	99.3	28.2	320	1.0	660	3700	14.1	320	0.51	660	5200	
AS 30 D_	120.9	23.2	320	0.84	660	4150	11.6	320	0.42	660	5500	
AS 30 D_	134.7	20.8	320	0.75	660	4400	10.4	320	0.38	660	5500	
AS 30 D_	151.1	18.5	320	0.67	660	4700	9.3	320	0.33	660	5500	

$n_1 = 900 \text{ min}^{-1}$							$n_1 = 500 \text{ min}^{-1}$					
		n_2 min^{-1}	M_{n2} Nm	P_{n1} kW	R_{n1} N	R_{n2} N	n_2 min^{-1}	M_{n2} Nm	P_{n1} kW	R_{n1} N	R_{n2} N	
AS 30_	5.11	176	320	6.2	400	1370	98	350	3.8	430	1590	77
AS 30_	6.22	145	320	5.1	590	1230	80	350	3.1	900	1790	
AS 30_	6.93	130	320	4.6	740	1210	72	350	2.8	1000	2080	
AS 30_	7.51	120	320	4.2	530	1670	67	350	2.6	670	2080	
AS 30_	7.78	116	320	4.1	1000	1610	64	350	2.5	1000	2270	
AS 30_	9.14	98	320	3.5	870	1810	55	350	2.1	1000	2440	
AS 30_	10.18	88	320	3.1	1000	1980	49	350	1.9	1000	2650	
AS 30_	11.43	79	320	2.8	1000	2170	44	350	1.7	1000	2870	
AS 30_	12.62	71	320	2.5	680	2170	39.6	350	1.5	1000	2890	
AS 30_	15.37	59	320	2.1	1000	2520	32.5	350	1.3	1000	3310	
AS 30_	17.11	53	320	1.9	1000	2720	29.2	350	1.1	1000	3540	
AS 30_	19.21	47	320	1.7	1000	2930	26.0	350	1.0	1000	3800	
AS 30_	24.19	37.2	320	1.3	1000	3180	20.7	350	0.80	1000	4120	
AS 30_	29.45	30.6	320	1.1	1000	3600	17.0	350	0.65	1000	4620	
AS 30_	32.8	27.4	320	0.97	1000	3840	15.2	350	0.59	1000	4900	
AS 30_	36.82	24.4	320	0.86	1000	4090	13.6	350	0.52	1000	5210	
AS 30 D_	41.2	21.8	350	0.86	660	4100	12.1	350	0.48	660	5450	
AS 30 D_	46.2	19.5	350	0.77	660	4400	10.8	350	0.43	660	5500	
AS 30 D_	54.0	16.7	350	0.66	660	4600	9.3	350	0.37	660	5500	
AS 30 D_	65.8	13.7	350	0.54	660	5200	7.6	350	0.30	660	5500	
AS 30 D_	73.6	12.2	350	0.48	660	5450	6.8	350	0.27	660	5500	
AS 30 D_	82.2	10.9	350	0.43	660	5500	6.1	350	0.24	660	5500	
AS 30 D_	99.3	9.1	350	0.36	660	5500	5.0	350	0.20	660	5500	
AS 30 D_	120.9	7.4	350	0.29	660	5500	4.1	350	0.16	660	5500	
AS 30 D_	134.7	6.7	350	0.26	660	5500	3.7	350	0.15	660	5500	
AS 30 D_	151.1	6.0	350	0.24	660	5500	3.3	350	0.13	660	5500	





AS 35

530 Nm

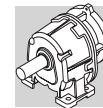
	i	$n_1 = 2800 \text{ min}^{-1}$					$n_1 = 1400 \text{ min}^{-1}$					
		n_2 min^{-1}	M_{n2} Nm	P_{n1} kW	R_{n1} N	R_{n2} N	n_2 min^{-1}	M_{n2} Nm	P_{n1} kW	R_{n1} N	R_{n2} N	
AS 35_	5.11	548	270	16.3	640	3690	274	340	10.3	900	4500	79
AS 35_	6.22	450	270	13.4	850	4060	225	340	8.4	1050	4950	
AS 35_	6.93	404	270	12.0	910	4260	202	340	7.6	1140	5200	
AS 35_	7.51	373	270	11.1	830	4330	186	340	7.0	1050	5280	
AS 35_	7.78	360	270	10.7	960	4490	180	340	6.7	1200	5480	
AS 35_	9.14	306	320	10.8	850	4460	153	400	6.7	1100	5460	
AS 35_	10.18	275	320	9.7	910	4690	138	400	6.1	1150	5740	
AS 35_	11.43	245	320	8.6	960	4940	122	400	5.4	1150	6050	
AS 35_	12.62	222	360	8.8	660	4800	111	400	4.9	1050	6160	
AS 35_	15.37	182	360	7.2	880	5290	91	400	4.0	1150	6750	
AS 35_	17.11	164	360	6.5	940	5560	82	400	3.6	1150	7070	
AS 35_	19.21	146	360	5.8	990	5850	73	400	3.2	1150	7200	
AS 35_	24.19	116	480	6.1	370	5600	58	480	3.1	1150	7200	
AS 35_	29.45	95	480	5.0	700	6190	48	480	2.5	1150	7200	
AS 35_	32.8	85	480	4.5	860	6530	43	480	2.3	1150	7200	
AS 35_	36.82	76	480	4.0	920	6890	38	480	2.0	1150	7200	
AS 35 D_	41.2	68	480	3.7	700	7200	34	480	1.8	830	7200	
AS 35 D_	46.2	61	480	3.3	750	7200	30	480	1.6	830	7200	
AS 35 D_	54.0	52	480	2.8	650	7200	25.9	480	1.4	830	7200	
AS 35 D_	65.8	43	480	2.3	750	7200	21.3	480	1.2	830	7200	
AS 35 D_	73.6	38	480	2.1	830	7200	19.0	480	1.0	830	7200	
AS 35 D_	82.2	34	480	1.8	830	7200	17.0	480	0.92	830	7200	
AS 35 D_	99.3	28.2	480	1.5	750	7200	14.1	480	0.76	830	7200	
AS 35 D_	120.9	23.2	480	1.3	830	7200	11.6	480	0.63	830	7200	
AS 35 D_	134.7	20.8	480	1.1	830	7200	10.4	480	0.56	830	7200	
AS 35 D_	151.1	18.5	480	1.0	830	7200	9.3	480	0.50	830	7200	
$n_1 = 900 \text{ min}^{-1}$						$n_1 = 500 \text{ min}^{-1}$						
AS 35_	5.11	176	480	9.3	590	4610	98	530	5.7	1110	5740	79
AS 35_	6.22	145	480	7.6	1060	5150	80	530	4.7	1160	6380	
AS 35_	6.93	130	480	6.9	1160	5450	72	530	4.2	1160	6730	
AS 35_	7.51	120	480	6.3	970	5510	67	530	3.9	1160	6810	
AS 35_	7.78	116	480	6.1	1160	5770	64	530	3.8	1160	7110	
AS 35_	9.14	98	480	5.2	1160	6100	55	530	3.2	1160	7200	
AS 35_	10.18	88	480	4.7	1160	6430	49	530	2.9	1160	7200	
AS 35_	11.43	79	480	4.2	1160	6790	44	530	2.6	1160	7200	
AS 35_	12.62	71	480	3.8	1160	6900	40	530	2.3	1160	7200	
AS 35_	15.37	59	480	3.1	1160	7200	33	530	1.9	1160	7200	
AS 35_	17.11	53	480	2.8	1160	7200	29.2	530	1.7	1160	7200	
AS 35_	19.21	47	480	2.5	1160	7200	26.0	530	1.5	1160	7200	
AS 35_	24.19	37	480	2.0	1160	7200	20.7	530	1.2	1160	7200	
AS 35_	29.45	31	480	1.6	1160	7200	17.0	530	0.99	1160	7200	
AS 35_	32.8	27.4	480	1.5	1160	7200	15.2	530	0.89	1160	7200	
AS 35_	36.82	24.4	480	1.3	1160	7200	13.6	530	0.79	1160	7200	
AS 35 D_	41.2	21.8	530	1.3	830	7200	12.1	530	0.73	830	7200	
AS 35 D_	46.2	19.5	530	1.2	830	7200	10.8	530	0.65	830	7200	
AS 35 D_	54.0	16.7	530	1.0	830	7200	9.3	530	0.55	830	7200	
AS 35 D_	65.8	13.7	530	0.82	830	7200	7.6	530	0.45	830	7200	
AS 35 D_	73.6	12.2	530	0.73	830	7200	6.8	530	0.41	830	7200	
AS 35 D_	82.2	10.9	530	0.66	830	7200	6.1	530	0.36	830	7200	
AS 35 D_	99.3	9.1	530	0.54	830	7200	5.0	530	0.30	830	7200	
AS 35 D_	120.9	7.4	530	0.45	830	7200	4.1	530	0.25	830	7200	
AS 35 D_	134.7	6.7	530	0.40	830	7200	3.7	530	0.22	830	7200	
AS 35 D_	151.1	6.0	530	0.36	830	7200	3.3	530	0.20	830	7200	



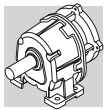

	i	$n_1 = 2800 \text{ min}^{-1}$					$n_1 = 1400 \text{ min}^{-1}$					
		n_2 min^{-1}	M_{n2} Nm	P_{n1} kW	R_{n1} N	R_{n2} N	n_2 min^{-1}	M_{n2} Nm	P_{n1} kW	R_{n1} N	R_{n2} N	
AS 45_	4.42	633	420	29.3	1750	3500	317	520	18.1	1750	4250	81
AS 45_	4.89	573	420	26.5	1750	3700	286	520	16.4	1750	4500	
AS 45_	5.43	516	420	23.8	1750	3900	258	520	14.8	1750	4800	
AS 45_	6.07	461	420	21.3	1750	4100	231	520	13.2	1750	5050	
AS 45_	8.14	344	520	19.7	1750	4100	172	650	12.3	1750	5000	
AS 45_	9.0	311	520	17.8	1750	4300	156	650	11.1	1750	5300	
AS 45_	10.0	280	520	16.0	1750	4600	140	650	10.0	1750	5600	
AS 45_	11.18	250	520	14.3	1750	4900	125	650	9.0	1750	6000	
AS 45_	12.89	217	590	14.1	1750	4700	109	650	7.8	1750	6200	
AS 45_	14.25	196	590	12.8	1750	5000	98	650	7.0	1750	6500	
AS 45_	15.83	177	590	11.5	1750	5300	88	650	6.3	1750	6900	
AS 45_	17.7	158	590	10.3	1750	5600	79	650	5.7	1750	7300	
AS 45_	19.99	140	720	11.1	1750	5200	70	720	5.6	1750	7200	
AS 45_	22.09	127	720	10.0	1750	5500	63	720	5.0	1750	7500	
AS 45_	24.55	114	720	9.0	1750	5800	57	720	4.5	1750	8000	
AS 45_	27.45	102	720	8.1	1750	6200	51	720	4.0	1750	8400	
AS 45 D_	31.1	90	720	7.3	1050	7150	45	720	3.7	1080	9400	
AS 45 D_	34.4	81	720	6.6	1080	7500	41	720	3.3	1080	9500	
AS 45 D_	38.2	73	720	6.0	1080	7900	37	720	3.0	1080	9500	
AS 45 D_	42.7	66	720	5.3	1080	8300	33	720	2.7	1080	9500	
AS 45 D_	45.7	61	720	5.0	1080	8350	31	720	2.5	1080	9500	
AS 45 D_	50.5	55	720	4.5	1080	8800	27.7	720	2.3	1080	9500	
AS 45 D_	56.1	50	720	4.1	1080	9200	25.0	720	2.0	1080	9500	
AS 45 D_	62.7	45	720	3.6	1080	9500	22.3	720	1.8	1080	9500	
AS 45 D_	76.8	36	720	3.0	1080	9500	18.2	720	1.5	1080	9500	
AS 45 D_	84.9	33	720	2.7	1080	9500	16.5	720	1.3	1080	9500	
AS 45 D_	94.3	29.7	720	2.4	1080	9500	14.8	720	1.2	1080	9500	
AS 45 D_	105.5	26.5	720	2.2	1080	9500	13.3	720	1.1	1080	9500	
AS 45 D_	147.2	19.0	720	1.5	1080	9500	9.5	720	0.77	1080	9500	
AS 45 D_	162.7	17.2	720	1.4	1080	9500	8.6	720	0.70	1080	9500	
AS 45 D_	180.7	15.5	720	1.3	1080	9500	7.7	720	0.63	1080	9500	
AS 45 D_	202.1	13.9	720	1.1	1080	9500	6.9	720	0.56	1080	9500	





AS 45

800 Nm

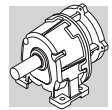
	i	$n_1 = 900 \text{ min}^{-1}$					$n_1 = 500 \text{ min}^{-1}$					
		n_2 min^{-1}	M_{n2} Nm	P_{n1} kW	R_{n1} N	R_{n2} N	n_2 min^{-1}	M_{n2} Nm	P_{n1} kW	R_{n1} N	R_{n2} N	
AS 45_	4.42	204	720	16.1	1750	4250	113	800	10.0	1750	5350	81
AS 45_	4.89	184	720	14.6	1750	4600	102	800	9.0	1750	5700	
AS 45_	5.43	166	720	13.1	1750	4900	92	800	8.1	1750	6100	
AS 45_	6.07	148	720	11.8	1750	5200	82	800	7.3	1750	6500	
AS 45_	8.14	111	720	8.8	1750	5800	61	800	5.4	1750	7200	
AS 45_	9.0	100	720	7.9	1750	6200	56	800	4.9	1750	7600	
AS 45_	10.0	90	720	7.1	1750	6500	50	800	4.4	1750	8000	
AS 45_	11.18	81	720	6.4	1750	6900	45	800	3.9	1750	8500	
AS 45_	12.89	70	720	5.5	1750	7200	39	800	3.4	1750	8800	
AS 45_	14.25	63	720	5.0	1750	7600	35	800	3.1	1750	9300	
AS 45_	15.83	57	720	4.5	1750	8000	32	800	2.8	1750	9500	
AS 45_	17.7	51	720	4.0	1750	8400	28.2	800	2.5	1750	9500	
AS 45_	19.99	45	720	3.6	1750	8700	25.0	800	2.2	1750	9500	
AS 45_	22.09	41	720	3.2	1750	9100	22.6	800	2.0	1750	9500	
AS 45_	24.55	37	720	2.9	1750	9500	20.4	800	1.8	1750	9500	
AS 45_	27.45	33	720	2.6	1750	9500	18.2	800	1.6	1750	9500	
AS 45 D_	31.1	28.9	800	2.6	1080	9500	16.1	800	1.5	1080	9500	
AS 45 D_	34.4	26.2	800	2.4	1080	9500	14.5	800	1.3	1080	9500	
AS 45 D_	38.2	23.6	800	2.1	1080	9500	13.1	800	1.2	1080	9500	
AS 45 D_	42.7	21.1	800	1.9	1080	9500	11.7	800	1.1	1080	9500	
AS 45 D_	45.7	19.7	800	1.8	1080	9500	10.9	800	0.99	1080	9500	
AS 45 D_	50.5	17.8	800	1.6	1080	9500	9.9	800	0.89	1080	9500	
AS 45 D_	56.1	16.0	800	1.4	1080	9500	8.9	800	0.81	1080	9500	
AS 45 D_	62.7	14.4	800	1.3	1080	9500	8.0	800	0.72	1080	9500	
AS 45 D_	76.8	11.7	800	1.1	1080	9500	6.5	800	0.59	1080	9500	
AS 45 D_	84.9	10.6	800	0.96	1080	9500	5.9	800	0.53	1080	9500	
AS 45 D_	94.3	9.5	800	0.86	1080	9500	5.3	800	0.48	1080	9500	
AS 45 D_	105.5	8.5	800	0.77	1080	9500	4.7	800	0.43	1080	9500	
AS 45 D_	147.2	6.1	800	0.55	1080	9500	3.4	800	0.31	1080	9500	
AS 45 D_	162.7	5.5	800	0.50	1080	9500	3.1	800	0.28	1080	9500	
AS 45 D_	180.7	5.0	800	0.45	1080	9500	2.8	800	0.25	1080	9500	
AS 45 D_	202.1	4.5	800	0.40	1080	9500	2.5	800	0.22	1080	9500	



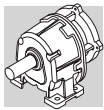

	i	$n_1 = 2800 \text{ min}^{-1}$					$n_1 = 1400 \text{ min}^{-1}$					
		n_2 min^{-1}	M_{n2} Nm	P_{n1} kW	R_{n1} N	R_{n2} N	n_2 min^{-1}	M_{n2} Nm	P_{n1} kW	R_{n1} N	R_{n2} N	
AS 55_	4.55	615	640	43	2350	6460	308	800	27	2500	7890	83
AS 55_	5.07	552	640	39	2500	6850	276	800	24	2500	8400	
AS 55_	5.68	493	640	35	2500	7300	246	800	22	2500	8900	
AS 55_	6.42	436	640	31	2500	7720	218	800	19	2500	9450	
AS 55_	7.31	383	900	38	1230	6650	192	1100	23	1616	8200	
AS 55_	8.14	344	900	34	2240	7100	172	1100	21	2500	8800	
AS 55_	9.13	307	900	30	2420	7600	153	1100	18.6	2500	9400	
AS 55_	10.31	272	900	27	2500	8150	136	1100	16.4	2500	10100	
AS 55_	11.31	248	1000	27	1210	7700	124	1100	15.0	2500	10100	
AS 55_	12.6	222	1000	24	2250	8250	111	1100	13.5	2500	10800	
AS 55_	14.13	198	1000	22	2430	8800	99	1100	12.0	2500	11500	
AS 55_	15.96	175	1000	19.3	2500	9400	88	1100	10.6	2500	12200	
AS 55_	18.31	153	1100	18.5	1030	9150	76	1200	10.1	2500	12000	
AS 55_	20.4	137	1200	18.1	1270	9300	69	1200	9.1	2500	12800	
AS 55_	22.87	122	1200	16.2	2280	9950	61	1200	8.1	2500	13600	
AS 55_	25.84	108	1200	14.3	2470	10700	54	1200	7.2	2500	14400	
AS 55 D_	29.8	94	1200	12.7	1050	12100	47	1200	6.4	1600	15000	
AS 55 D_	33.2	84	1200	11.4	1300	12800	42	1200	5.7	1600	15000	
AS 55 D_	37.2	75	1200	10.2	1500	13500	38	1200	5.1	1600	15000	
AS 55 D_	42.1	67	1200	9.0	1600	14300	33	1200	4.5	1600	15000	
AS 55 D_	54.9	51	1200	6.9	1500	15000	26	1200	3.5	1600	15000	
AS 55 D_	61.2	46	1200	6.2	1600	15000	22.9	1200	3.1	1600	15000	
AS 55 D_	68.6	41	1200	5.5	1600	15000	20.4	1200	2.8	1600	15000	
AS 55 D_	77.5	36	1200	4.9	1600	15000	18.1	1200	2.4	1600	15000	
AS 55 D_	87.0	32	1200	4.4	1600	15000	16.1	1200	2.2	1600	15000	
AS 55 D_	96.9	29	1200	3.9	1600	15000	14.4	1200	2.0	1600	15000	
AS 55 D_	108.6	25.8	1200	3.5	1600	15000	12.9	1200	1.7	1600	15000	
AS 55 D_	122.7	22.8	1200	3.1	1600	15000	11.4	1200	1.5	1600	15000	
AS 55 D_	134.8	20.8	1200	2.8	1600	15000	10.4	1200	1.4	1600	15000	
AS 55 D_	150.2	18.6	1200	2.5	1600	15000	9.3	1200	1.3	1600	15000	
AS 55 D_	168.4	16.6	1200	2.3	1600	15000	8.3	1200	1.1	1600	15000	
AS 55 D_	190.3	14.7	1200	2.0	1600	15000	7.4	1200	1.0	1600	15000	





AS 55

1350 Nm

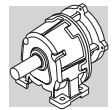
	i	$n_1 = 900 \text{ min}^{-1}$					$n_1 = 500 \text{ min}^{-1}$					
		n_2 min^{-1}	M_{n2} Nm	P_{n1} kW	R_{n1} N	R_{n2} N	n_2 min^{-1}	M_{n2} Nm	P_{n1} kW	R_{n1} N	R_{n2} N	
AS 55_	4.55	198	1200	26	1500	8080	110	1350	16.3	1250	10000	83
AS 55_	5.07	178	1200	23	1800	8160	99	1350	14.7	2500	10000	
AS 55_	5.68	158	1200	21	2500	8790	88	1350	13.1	2500	11000	
AS 55_	6.42	140	1200	18.5	2500	9450	78	1350	11.6	2500	11700	
AS 55_	7.31	123	1200	16.3	2500	9650	68	1350	10.2	2500	11900	
AS 55_	8.14	111	1200	14.6	2500	10300	61	1350	9.1	2500	12700	
AS 55_	9.13	99	1200	13.0	2500	11000	55	1350	8.1	2500	13500	
AS 55_	10.31	87	1200	11.5	2500	11750	48	1350	7.2	2500	14400	
AS 55_	11.31	80	1200	10.5	2500	11840	44	1350	6.6	2500	14500	
AS 55_	12.6	71	1200	9.4	2500	12560	40	1350	5.9	2500	15000	
AS 55_	14.13	64	1200	8.4	2500	13340	35	1350	5.3	2500	15000	
AS 55_	15.96	56	1200	7.5	2500	14170	31.3	1350	4.7	2500	15000	
AS 55_	18.31	49	1200	6.5	2500	14610	27.3	1350	4.1	2500	15000	
AS 55_	20.4	44	1200	5.8	2500	15000	24.5	1350	3.6	2500	15000	
AS 55_	22.87	39	1200	5.2	2500	15000	21.9	1350	3.2	2500	15000	
AS 55_	25.84	35	1200	4.6	2500	15000	19.3	1350	2.9	2500	15000	
AS 55 D_	29.8	30.2	1350	4.6	1600	15000	16.8	1350	2.6	1600	15000	
AS 55 D_	33.2	27.1	1350	4.1	1600	15000	15.1	1350	2.3	1600	15000	
AS 55 D_	37.2	24.2	1350	3.7	1600	15000	13.4	1350	2.0	1600	15000	
AS 55 D_	42.1	21.4	1350	3.3	1600	15000	11.9	1350	1.8	1600	15000	
AS 55 D_	54.9	16.4	1350	2.5	1600	15000	9.1	1350	1.4	1600	15000	
AS 55 D_	61.2	14.7	1350	2.2	1600	15000	8.2	1350	1.2	1600	15000	
AS 55 D_	68.6	13.1	1350	2.0	1600	15000	7.3	1350	1.1	1600	15000	
AS 55 D_	77.5	11.6	1350	1.8	1600	15000	6.5	1350	0.98	1600	15000	
AS 55 D_	87.0	10.3	1350	1.6	1600	15000	5.7	1350	0.88	1600	15000	
AS 55 D_	96.9	9.3	1350	1.4	1600	15000	5.2	1350	0.79	1600	15000	
AS 55 D_	108.6	8.3	1350	1.3	1600	15000	4.6	1350	0.70	1600	15000	
AS 55 D_	122.7	7.3	1350	1.1	1600	15000	4.1	1350	0.62	1600	15000	
AS 55 D_	134.8	6.7	1350	1.0	1600	15000	3.7	1350	0.57	1600	15000	
AS 55 D_	150.2	6.0	1350	0.91	1600	15000	3.3	1350	0.51	1600	15000	
AS 55 D_	168.4	5.3	1350	0.81	1600	15000	3.0	1350	0.45	1600	15000	
AS 55 D_	190.3	4.7	1350	0.72	1600	15000	2.6	1350	0.40	1600	15000	



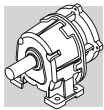

	i	$n_1 = 2800 \text{ min}^{-1}$					$n_1 = 1400 \text{ min}^{-1}$					
		n_2 min^{-1}	M_{n2} Nm	P_{n1} kW	R_{n1} N	R_{n2} N	n_2 min^{-1}	M_{n2} Nm	P_{n1} kW	R_{n1} N	R_{n2} N	
AS 60_	4.34	645	1100	78	1790	4540	323	1400	50	2230	5420	85
AS 60_	4.8	583	1100	71	1980	4890	292	1400	45	2470	5850	
AS 60_	5.33	525	1100	64	2150	5260	263	1400	40	2690	6310	
AS 60_	5.96	470	1100	57	2320	5640	235	1400	36	2900	6790	
AS 60_	7.37	380	1500	63	1550	4160	190	1900	40	1940	4450	
AS 60_	8.14	344	1500	57	1760	4960	172	1900	36	2210	5830	
AS 60_	9.05	309	1500	51	1960	5410	155	1900	32	2450	6470	
AS 60_	10.12	277	1500	46	2140	5880	138	1900	29	2690	7050	
AS 60_	11.4	246	1700	46	1530	4860	123	1900	26	2240	7130	
AS 60_	12.6	222	1700	42	1740	5690	111	1900	23	2470	7710	
AS 60_	14.0	200	1700	37	1940	6200	100	1900	21	2690	8320	
AS 60_	15.65	179	1700	33	2120	6740	89	1900	18.7	2900	8960	
AS 60_	18.55	151	1900	32	1060	6280	75	2100	17.5	2120	8620	
AS 60_	20.5	137	2100	32	1060	5500	68	2100	15.8	2360	9180	
AS 60_	22.78	123	2100	28	1630	6700	61	2100	14.2	2590	9980	
AS 60_	25.47	110	2100	25	1850	7330	55	2100	12.7	2820	10700	
AS 60 D_	30.2	93	2100	22	1620	9160	46	2100	11.0	2210	12700	
AS 60 D_	33.4	84	2100	19.9	1680	9790	42	2100	9.9	2270	13500	
AS 60 D_	37.1	75	2100	17.9	1740	10500	38	2100	9.0	2330	14200	
AS 60 D_	41.5	67	2100	16.0	1800	11200	34	2100	8.0	2350	15100	
AS 60 D_	55.6	50	2100	11.9	1770	12300	25	2100	6.0	2350	16500	
AS 60 D_	61.5	46	2100	10.8	1810	13000	22.8	2100	5.4	2350	17400	
AS 60 D_	68.3	41	2100	9.7	1860	13800	20.5	2100	4.9	2350	18300	
AS 60 D_	76.4	37	2100	8.7	1900	14600	18.3	2100	4.3	2350	19300	
AS 60 D_	88.1	32	2100	7.5	1830	15000	15.9	2100	3.8	2350	19100	
AS 60 D_	97.4	29	2100	6.8	1870	15800	14.4	2100	3.4	2350	20900	
AS 60 D_	108.2	25.9	2100	6.1	1910	16700	12.9	2100	3.1	2350	21900	
AS 60 D_	121.0	23.1	2100	5.5	1950	17600	11.6	2100	2.7	2350	22000	
AS 60 D_	136.6	20.5	2100	4.9	1870	18000	10.2	2100	2.4	2350	22000	
AS 60 D_	151.0	18.5	2100	4.4	1900	18900	9.3	2100	2.2	2350	22000	
AS 60 D_	167.7	16.7	2100	4.0	1940	19800	8.3	2100	2.0	2350	22000	
AS 60 D_	187.5	14.9	2100	3.5	1980	20900	7.5	2100	1.8	1400	22000	





AS 60

2300 Nm

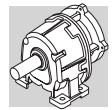
	i	$n_1 = 900 \text{ min}^{-1}$					$n_1 = 500 \text{ min}^{-1}$					
		n_2 min^{-1}	M_{n2} Nm	P_{n1} kW	R_{n1} N	R_{n2} N	n_2 min^{-1}	M_{n2} Nm	P_{n1} kW	R_{n1} N	R_{n2} N	
AS 60_	4.34	207	2100	48	1620	3680	115	2300	29	1610	3900	85
AS 60_	4.8	188	2100	43	1620	2360	104	2300	26	2960	5700	
AS 60_	5.33	169	2100	39	2440	4130	94	2300	24	3330	7190	
AS 60_	5.96	151	2100	35	2750	5680	84	2300	21	3670	7880	
AS 60_	7.37	122	2100	28	2400	5950	68	2300	17.2	3290	8410	
AS 60_	8.14	111	2100	26	2690	7010	61	2300	15.6	3600	9100	
AS 60_	9.05	99	2100	23	2960	7630	55	2300	14.0	3680	9830	
AS 60_	10.12	89	2100	21	3220	8290	49	2300	12.5	3680	10610	
AS 60_	11.4	79	2100	18.3	2720	8400	44	2300	11.1	3640	10780	
AS 60_	12.6	71	2100	16.5	2980	9050	40	2300	10.0	3680	11540	
AS 60_	14.0	64	2100	14.9	3230	9740	36	2300	9.0	3680	12350	
AS 60_	15.65	58	2100	13.3	3460	10480	31.9	2300	8.1	3680	13210	
AS 60_	18.55	49	2100	11.2	2860	10940	27.0	2300	6.8	3680	13810	
AS 60_	20.5	44	2100	10.2	3110	11680	24.4	2300	6.2	3680	14670	
AS 60_	22.78	40	2100	9.1	3340	12450	21.9	2300	5.6	3680	15580	
AS 60_	25.47	35	2100	8.2	3560	13270	19.6	2300	5.0	3680	16550	
AS 60 D_	30.2	29.8	2300	7.7	2350	14810	16.6	2300	4.3	2350	18990	
AS 60 D_	33.4	26.9	2300	7.0	2350	15650	15.0	2300	3.9	2350	19950	
AS 60 D_	37.1	24.3	2300	6.3	2350	16530	13.5	2300	3.5	2350	20970	
AS 60 D_	41.5	21.7	2300	5.6	2350	17480	12.0	2300	3.1	2350	22000	
AS 60 D_	55.6	16.2	2300	4.2	2350	19170	9.0	2300	2.3	2350	22000	
AS 60 D_	61.5	14.6	2300	3.8	2350	20140	8.1	2300	2.1	2350	22000	
AS 60 D_	68.3	13.2	2300	3.4	2350	21170	7.3	2300	1.9	2350	22000	
AS 60 D_	76.4	11.8	2300	3.1	2350	22000	6.5	2300	1.7	2350	22000	
AS 60 D_	88.1	10.2	2300	2.7	2350	22000	5.7	2300	1.5	2350	22000	
AS 60 D_	97.4	9.2	2300	2.4	2350	22000	5.1	2300	1.3	2350	22000	
AS 60 D_	108.2	8.3	2300	2.2	2350	22000	4.6	2300	1.2	2350	22000	
AS 60 D_	121.0	7.4	2300	1.9	2350	22000	4.1	2300	1.1	2350	22000	
AS 60 D_	136.6	6.6	2300	1.7	2350	22000	3.7	2300	0.95	2350	22000	
AS 60 D_	151.0	6.0	2300	1.5	2350	22000	3.3	2300	0.86	2350	22000	
AS 60 D_	167.7	5.4	2300	1.4	2350	22000	3.0	2300	0.77	2350	22000	
AS 60 D_	187.5	4.8	2300	1.2	2350	22000	2.7	2300	0.69	2350	22000	



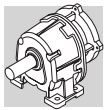

	i	$n_1 = 2800 \text{ min}^{-1}$					$n_1 = 1400 \text{ min}^{-1}$					
		n_2 min^{-1}	M_{n2} Nm	P_{n1} kW	R_{n1} N	R_{n2} N	n_2 min^{-1}	M_{n2} Nm	P_{n1} kW	R_{n1} N	R_{n2} N	
AS 80_	4.34	645	1900	135	3560	12200	323	2400	85	4380	14900	87
AS 80_	4.8	583	1900	122	3790	12300	292	2400	77	4760	15800	
AS 80_	5.33	525	1900	110	4000	13800	263	2400	69	5000	16800	
AS 80_	5.96	470	1900	98	4200	14600	235	2400	62	5000	17800	
AS 80_	7.37	380	2600	109	1170	10500	190	3200	67	1450	13000	
AS 80_	8.14	344	2600	98	3340	12700	172	3200	61	4150	15700	
AS 80_	9.05	309	2600	89	3760	14800	155	3200	55	4800	18300	
AS 80_	10.12	277	2600	79	3990	15800	138	3200	49	5000	19500	
AS 80_	11.4	246	2900	78	1040	12900	123	3200	43	4200	19900	
AS 80_	12.6	222	2900	71	3230	15400	111	3200	39	4850	21100	
AS 80_	14.0	200	2900	64	3770	17100	100	3200	35	5000	22400	
AS 80_	15.65	179	2900	57	4000	18300	89	3200	32	5000	23800	
AS 80_	18.46	152	3000	50	2060	18600	76	3800	32	1750	22600	
AS 80_	20.4	137	3200	48	2830	19100	69	3800	29	4400	24000	
AS 80_	22.67	124	3800	52	1370	15000	62	3800	26	4900	25500	
AS 80_	25.35	110	3800	46	3620	18200	55	3800	23	5000	27200	
AS 80 D_	31.2	90	3800	39	1940	19000	45	3800	19.3	2800	29000	
AS 80 D_	34.5	81	3800	35	2070	21100	41	3800	17.4	2900	30500	
AS 80 D_	38.3	73	3800	31	2190	23600	37	3800	15.7	3000	31000	
AS 80 D_	42.8	65	3800	28	2300	25100	33	3800	14.0	3150	31000	
AS 80 D_	50.1	56	3800	24	2140	26100	27.9	3800	12.0	3000	31000	
AS 80 D_	55.4	51	3800	22	2250	27600	25.3	3800	10.8	3100	31000	
AS 80 D_	61.5	46	3800	19.5	2350	29300	22.8	3800	9.8	3200	31000	
AS 80 D_	68.8	41	3800	17.5	2440	31000	20.3	3800	8.7	3300	31000	
AS 80 D_	77.5	36	3800	15.5	2260	31000	18.1	3800	7.8	3100	31000	
AS 80 D_	85.7	33	3800	14.0	2350	31000	16.3	3800	7.0	3200	31000	
AS 80 D_	95.2	29.4	3800	12.6	2440	31000	14.7	3800	6.3	3300	31000	
AS 80 D_	106.5	26.3	3800	11.3	2530	31000	13.1	3800	5.6	3400	31000	
AS 80 D_	125.5	22.3	3800	9.6	2340	31000	11.2	3800	4.8	3200	31000	
AS 80 D_	138.7	20.2	3800	8.7	2430	31000	10.1	3800	4.3	3300	31000	
AS 80 D_	154.1	18.2	3800	7.8	2510	31000	9.1	3800	3.9	3400	31000	
AS 80 D_	172.3	16.3	3800	7.0	2590	31000	8.1	3800	3.5	3450	31000	





AS 80

4200 Nm

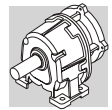
	i	$n_1 = 900 \text{ min}^{-1}$					$n_1 = 500 \text{ min}^{-1}$					
		n_2 min^{-1}	M_{n2} Nm	P_{n1} kW	R_{n1} N	R_{n2} N	n_2 min^{-1}	M_{n2} Nm	P_{n1} kW	R_{n1} N	R_{n2} N	
AS 80_	4.34	207	3800	87	2280	14200	115	4200	53	2500	31000	87
AS 80_	4.8	188	3800	78	3380	14200	104	4200	48	2300	31000	
AS 80_	5.33	169	3800	71	3000	11900	94	4200	43	4380	31000	
AS 80_	5.96	151	3800	63	4720	12400	84	4200	39	5000	31000	
AS 80_	7.37	122	3800	51	2120	15500	68	4200	31	3360	31000	
AS 80_	8.14	111	3800	46	3540	16000	61	4200	28	5000	31000	
AS 80_	9.05	99	3800	42	5000	19300	55	4200	26	5000	31000	
AS 80_	10.12	89	3800	37	5000	21700	49	4200	23	5000	31000	
AS 80_	11.4	79	3800	33	3650	21800	44	4200	20	5000	31000	
AS 80_	12.6	71	3800	30	5000	23500	40	4200	18.4	5000	31000	
AS 80_	14.0	64	3800	27	5000	25000	36	4200	16.5	5000	31000	
AS 80_	15.65	58	3800	24	5000	26700	32	4200	14.8	5000	31000	
AS 80_	18.46	49	3800	20	5000	27800	27.1	4200	12.5	5000	31000	
AS 80_	20.4	44	3800	18.5	5000	29400	24.5	4200	11.3	5000	31000	
AS 80_	22.67	40	3800	16.6	5000	31000	22.1	4200	10.2	5000	31000	
AS 80_	25.35	36	3800	14.9	5000	31000	19.7	4200	9.1	5000	31000	
AS 80 D_	31.2	28.8	4200	13.7	3300	31000	16.0	4200	7.6	3680	31000	
AS 80 D_	34.5	26.1	4200	12.4	3438	31000	14.5	4200	6.9	3680	31000	
AS 80 D_	38.3	23.5	4200	11.1	3569	31000	13.1	4200	6.2	3680	31000	
AS 80 D_	42.8	21.0	4200	10.0	3680	31000	11.7	4200	5.5	3680	31000	
AS 80 D_	50.1	18.0	4200	8.5	3522	31000	10.0	4200	4.7	3680	31000	
AS 80 D_	55.4	16.2	4200	7.7	3638	31000	9.0	4200	4.3	3680	31000	
AS 80 D_	61.5	14.6	4200	6.9	3680	31000	8.1	4200	3.9	3680	31000	
AS 80 D_	68.8	13.1	4200	6.2	3680	31000	7.3	4200	3.4	3680	31000	
AS 80 D_	77.5	11.6	4200	5.5	3680	31000	6.5	4200	3.1	3680	31000	
AS 80 D_	85.7	10.5	4200	5.0	3680	31000	5.8	4200	2.8	3680	31000	
AS 80 D_	95.2	9.5	4200	4.5	3680	31000	5.3	4200	2.5	3680	31000	
AS 80 D_	106.5	8.5	4200	4.0	3680	31000	4.7	4200	2.2	3680	31000	
AS 80 D_	125.5	7.2	4200	3.4	3680	31000	4.0	4200	1.9	3680	31000	
AS 80 D_	138.7	6.5	4200	3.1	3680	31000	3.6	4200	1.7	3680	31000	
AS 80 D_	154.1	5.8	4200	2.8	3680	31000	3.2	4200	1.5	3680	31000	
AS 80 D_	172.3	5.2	4200	2.5	3680	31000	2.9	4200	1.4	3680	31000	



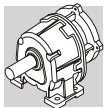

	i	$n_1 = 2800 \text{ min}^{-1}$					$n_1 = 1400 \text{ min}^{-1}$					
		n_2 min^{-1}	M_{n2} Nm	P_{n1} kW	R_{n1} N	R_{n2} N	n_2 min^{-1}	M_{n2} Nm	P_{n1} kW	R_{n1} N	R_{n2} N	
AS 90_	4.34	645	2800	199	1110	15900	323	3600	128	1640	17800	89
AS 90_	4.8	583	3000	193	1400	15900	292	4100	132	1280	15000	
AS 90_	5.33	525	3200	185	1770	16000	263	4100	119	2490	18000	
AS 90_	5.96	470	3300	171	2460	17500	235	4100	106	3660	21100	
AS 90_	7.37	380	3300	138	1370	18400	190	4100	86	2350	22200	
AS 90_	8.14	344	3600	136	1490	17600	172	4500	85	2430	21000	
AS 90_	9.05	309	4000	136	1490	16100	155	5300	90	1760	15700	
AS 90_	10.12	277	4300	131	1840	15900	138	5300	81	3000	19500	
AS 90_	11.4	246	3800	103	1100	20500	123	4800	65	1840	23900	
AS 90_	12.6	222	4000	98	1550	21300	111	5300	65	1850	22000	
AS 90_	14.0	200	4500	99	1440	19000	100	5300	58	3010	25900	
AS 90_	15.65	179	4700	93	2040	20200	89	5300	52	4130	30100	
AS 90_	18.46	152	4000	67	1420	26900	76	5300	44	1690	30400	
AS 90_	20.4	137	4500	68	1260	25900	69	6000	45	1410	26800	
AS 90_	22.67	124	5000	68	1260	24100	62	6200	42	2250	29200	
AS 90_	25.35	110	5600	68	1250	21600	55	6200	38	3430	34000	
AS 90 D_	29.5	95	6200	66	1800	14300	47	6200	33	2670	33900	
AS 90 D_	32.6	86	6200	60	1950	18600	43	6200	30	2820	38700	
AS 90 D_	36.3	77	6200	54	2090	22900	39	6200	27	2970	40800	
AS 90 D_	40.6	69	6200	48	2230	27500	34	6200	24	3100	42000	
AS 90 D_	50.1	56	6200	39	2080	28900	27.9	6200	19.6	2950	42000	
AS 90 D_	55.4	51	6200	35	2200	33600	25.3	6200	17.7	3080	42000	
AS 90 D_	61.5	46	6200	32	2320	38100	22.8	6200	15.9	3190	42000	
AS 90 D_	68.8	41	6200	29	2430	40300	20.3	6200	14.3	3300	42000	
AS 90 D_	77.5	36	6200	25	2220	41300	18.1	6200	12.7	3090	42000	
AS 90 D_	85.7	33	6200	23	2330	42000	16.3	6200	11.4	3200	42000	
AS 90 D_	95.2	29.4	6200	21	2430	42000	14.7	6200	10.3	3310	42000	
AS 90 D_	106.5	26.3	6200	18	2530	42000	13.1	6200	9.2	3410	42000	
AS 90 D_	126.1	22.2	6200	16	2270	42000	11.1	6200	7.8	3150	42000	
AS 90 D_	139.4	20.1	6200	14	2380	42000	10.0	6200	7.0	3250	42000	
AS 90 D_	154.9	18.1	6200	13	2480	42000	9.0	6200	6.3	3350	42000	
AS 90 D_	173.2	16.2	6200	11	2570	42000	8.1	6200	5.7	3450	42000	



AS 90

6800 Nm

	i	$n_1 = 900 \text{ min}^{-1}$					$n_1 = 500 \text{ min}^{-1}$					
		n_2 min^{-1}	M_{n2} Nm	P_{n1} kW	R_{n1} N	R_{n2} N	n_2 min^{-1}	M_{n2} Nm	P_{n1} kW	R_{n1} N	R_{n2} N	
AS 90_	4.34	207	4300	98	1830	18200	115	5800	74	1010	14100	89
AS 90_	4.8	188	4800	99	1690	15800	104	6200	71	1600	13600	
AS 90_	5.33	169	5300	99	1780	13800	94	6800	70	1820	11300	
AS 90_	5.96	151	5800	96	2070	12200	84	6800	63	3630	15900	
AS 90_	7.37	122	5300	71	1610	18300	68	6800	51	1620	16400	
AS 90_	8.14	111	5800	71	1740	16600	61	6800	46	3260	21100	
AS 90_	9.05	99	6200	68	2270	16300	55	6800	41	4840	25900	
AS 90_	10.12	89	6200	61	3670	20700	49	6800	37	6370	31000	
AS 90_	11.4	79	5800	50	1920	23600	44	6800	33	3470	29600	
AS 90_	12.6	71	6200	49	2370	23500	40	6800	30	4960	34600	
AS 90_	14.0	64	6200	44	3690	28000	36	6800	27	6390	39900	
AS 90_	15.65	58	6200	39	4970	32800	32	6800	24	7670	42000	
AS 90_	18.46	49	6200	33	2190	33000	27.1	6800	20	4760	42000	
AS 90_	20.4	44	6200	30	3460	37800	24.5	6800	18.4	6140	42000	
AS 90_	22.67	40	6200	27	4680	40400	22.1	6800	16.5	7470	42000	
AS 90_	25.35	36	6200	24	5870	42000	19.7	6800	14.8	8000	42000	
AS 90 D_	29.5	31	6800	23	3200	41900	16.9	6800	13.0	4260	42000	
AS 90 D_	32.6	27.6	6800	21	3360	42000	15.3	6800	11.8	4430	42000	
AS 90 D_	36.3	24.8	6800	19.0	3520	42000	13.8	6800	10.6	4580	42000	
AS 90 D_	40.6	22.2	6800	17.0	3670	42000	12.3	6800	9.5	4730	42000	
AS 90 D_	50.1	18.0	6800	13.8	3500	42000	10.0	6800	7.7	4570	42000	
AS 90 D_	55.4	16.2	6800	12.5	3640	42000	9.0	6800	6.9	4700	42000	
AS 90 D_	61.5	14.6	6800	11.2	3760	42000	8.1	6800	6.2	4830	42000	
AS 90 D_	68.8	13.1	6800	10.0	3890	42000	7.3	6800	5.6	4950	42000	
AS 90 D_	77.5	11.6	6800	8.9	3650	42000	6.5	6800	5.0	4720	42000	
AS 90 D_	85.7	10.5	6800	8.1	3770	42000	5.8	6800	4.5	4840	42000	
AS 90 D_	95.2	9.5	6800	7.3	3890	42000	5.3	6800	4.0	4950	42000	
AS 90 D_	106.5	8.5	6800	6.5	4000	42000	4.7	6800	3.6	5000	42000	
AS 90 D_	126.1	7.1	6800	5.5	3720	42000	4.0	6800	3.0	4780	42000	
AS 90 D_	139.4	6.5	6800	5.0	3830	42000	3.6	6800	2.8	4900	42000	
AS 90 D_	154.9	5.8	6800	4.5	3940	42000	3.2	6800	2.5	5000	42000	
AS 90 D_	173.2	5.2	6800	4.0	4040	42000	2.9	6800	2.2	5000	42000	

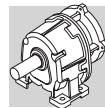

24 - PREDISPOSIZIONI POSSIBILI

Nella tabella (A11) vengono riportati gli abbinamenti motore possibili in termini puramente geometrici.

La scelta del motoriduttore deve essere effettuata seguendo le istruzioni specificate al paragrafo 10, rispettando in particolare la condizione $S \geq fs$.

(A12)

24 - MOTOR AVAILABILITY

Motor-gearbox combinations resulting from chart (A11) are purely based on geometrical compatibility.

When selecting a gearmotor, refer to procedure specified at para 10 and observe particularly the condition $S \geq fs$.

24 - ANBAUMÖGLICHKEITEN





In den Tabelle (A11) werden die von den Größen her gesehenen möglichen Passungen angegeben.

Die angemessene Getriebewahl muss unter Befolgung der im Paragraph 10 gegebenen Anleitungen und auf der Grundlage der Auswahltabelle der technischen Daten erfolgen.

24 - PREDISPOSITIONS POSSIBLES

Dans le tableau (A11) sont indiqués les accouplements possibles en termes de dimensions.

Le choix le plus approprié du réducteur à utiliser doit être effectué selon les indications du paragraphe 10, ainsi qu'en fonction des caractéristiques techniques des tableaux de sélection.

	i											
		63	71	80	90	100	112	132	160	180	200	225
AS 16	5.53 - 44.73											
AS 20	5.49 - 15.48											
	18.01 - 49.52											
AS 20 D	58.1 - 187.5											
AS 25	5.02 - 49.04											
AS 25 D	60.1 - 192.1											
AS 30	5.11 - 36.82											
AS 30 D	41.2 - 151.1											
AS 35	5.11 - 36.82											
AS 35 D	41.2 - 151.1											
AS 45	4.42 - 27.45											
AS 45 D	31.1 - 62.7											
	76.8 - 202.1											
AS 55	4.55 - 25.84											
AS 55 D	29.8 - 77.5											
	87 - 190.3											
AS 60	4.34 - 25.47											
AS 60 D	30.2 - 76.4											
	88.1 - 187.5											
AS 80	4.34 - 10.12											
	11.4 - 25.35											
AS 80 D	31.2 - 68.8											
	77.5 - 172.3											
AS 90	4.34 - 25.35											
AS 90 D	29.5 - 68.8											
	77.5 - 172.3											



In questo caso, se il riduttore è installato in una qualsiasi posizione di montaggio orizzontale è consigliabile che il motore sia nella forma costruttiva IM B35.



In this case, if the reducer is in any horizontal mounting position, it is recommended that the motor is IM B35 type.



In diesem Fall, wenn das Getriebe in irgendeiner waagrechten Einlaage installiert ist, wird empfohlen, einen Motor in der Bauform IM B35 zu verwenden.



Dans ce cas, si le réducteur est monté dans toute position horizontale, il est préconisé d'avoir un moteur du type IM B35.

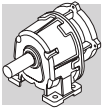

AS 16...P(IEC)

25 - DIMENSIONI

25 - DIMENSIONS

25 - ABMESSUNGEN

25 - DIMENSIONS

P

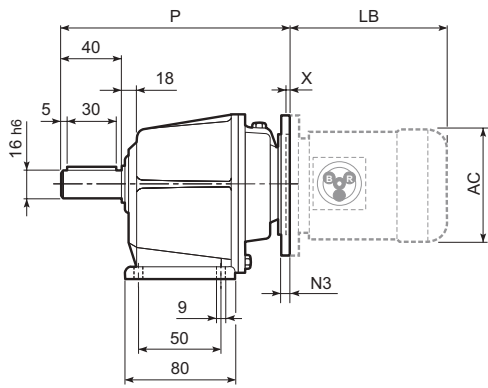

F

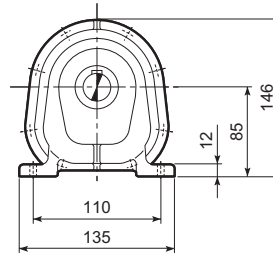
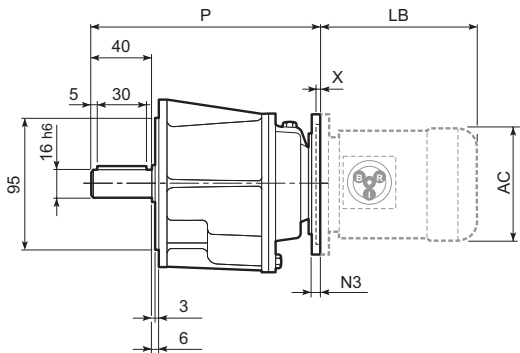

OUTPUT

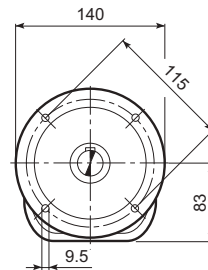
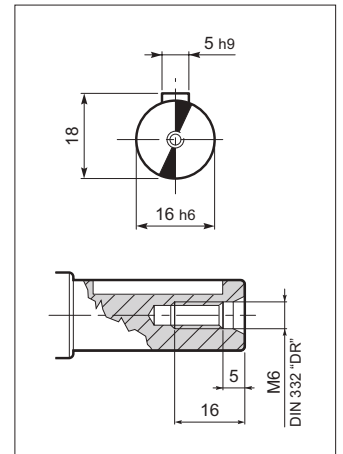

INPUT

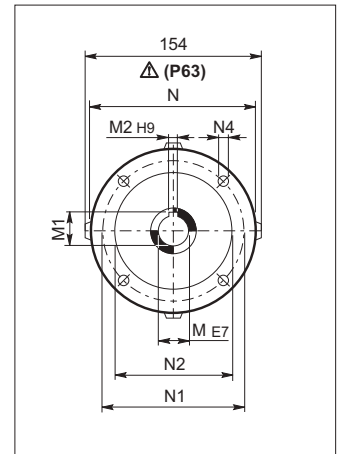

	AS 16													IEC	BN...		BN...FD BN...FA		
	M	M1	M2	N	N1	N2	N3	N4	X	P			kg		LB	AC	LB	AC	
										...P	...F	...R							
	AS 16_063	11	12.8	4	140	115	95	-	M8x19	5	170	-	-	3.4	BN 63	184	121	249	121
	AS 16_071	14	16.3	5	160	130	110	-	M8x16	5	170	-	-	3.4	BN 71	219	138	280	138

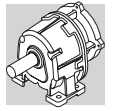

OUTPUT

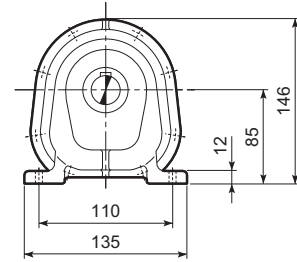
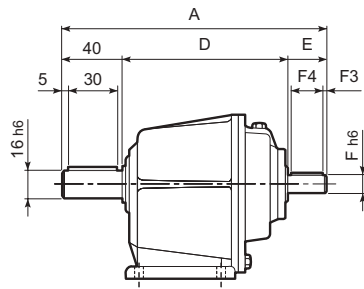
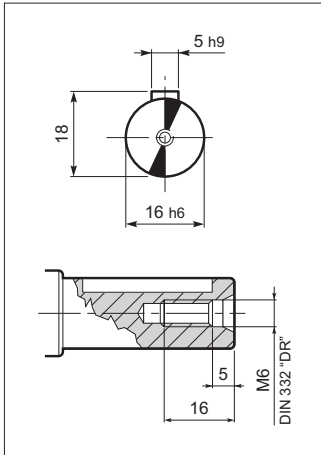

P

INPUT

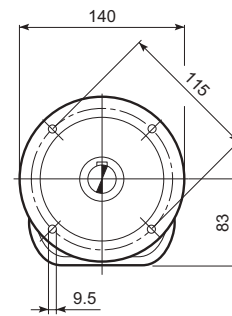
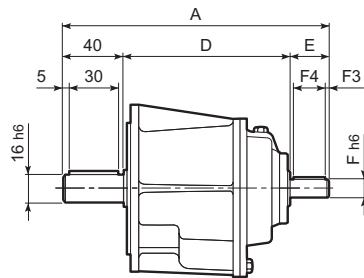
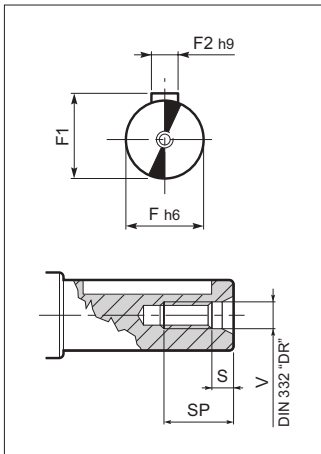

F

	AS 16											
	A	D	E	F	F1	F2	F3	F4	V	S	SP	Kg
AS 16 P_HS	206	126	40	16	18.8	5	5	30	M6	5	16	3.4
AS 16 F_HS	206	126	40	16	18.8	5	5	30	M6	5	16	3.4

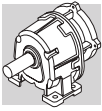

AS 20...P(IEC)

OUTPUT

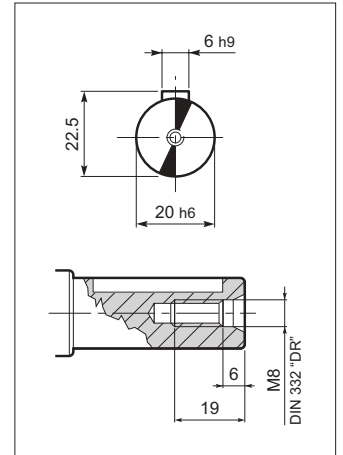

INPUT

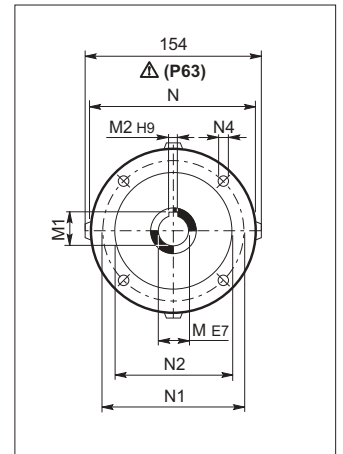

P
DP

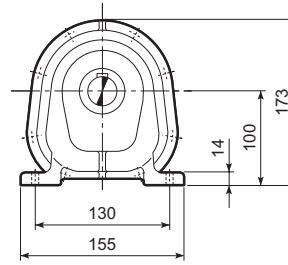
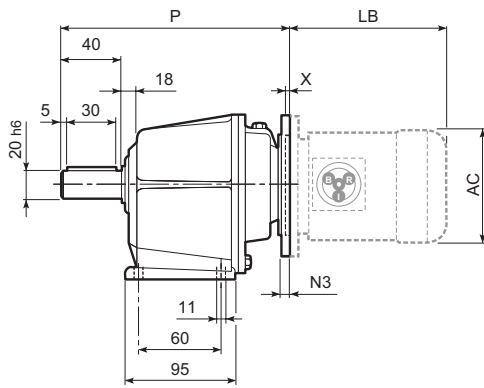

F
DF

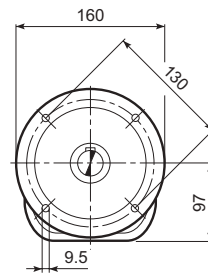
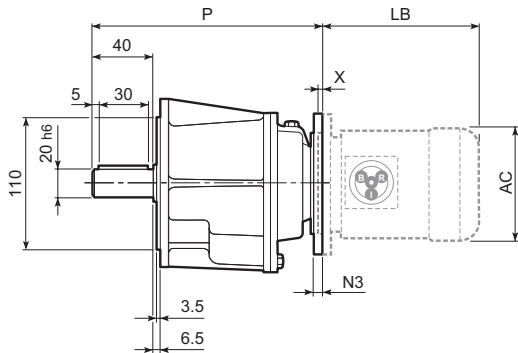

	AS 20													IEC	BN...		BN...FD BN...FA		
	M	M1	M2	N	N1	N2	N3	N4	X	P			kg		LB	AC	LB	AC	
										...P	...F	...R							
	AS 20_063	11	12.8	4	140	115	95	-	M8x19	5	195	195	-	6.4	BN 63	184	121	249	121
	AS 20_071	14	16.3	5	160	130	110	-	M8x16	5	195	195	-	6.4	BN 71	219	138	280	138
	AS 20_080	19	21.8	6	200	165	130	-	M10x12	5	200	200	-	6.4	BN 80	234	156	306	156
	AS 20_090	24	27.3	8	200	165	130	-	M10x12	5	200	200	-	6.4	BN 90	276	176	359	176
	AS 20 D_063	11	12.8	4	140	115	95	-	M8x19	3.5	194	194	-	6	BN 63	184	121	249	121
	AS 20 D_071	14	16.3	5	160	130	110	-	M8x16	3.5	194	194	-	6	BN 71	219	138	280	138

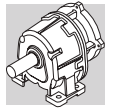

OUTPUT

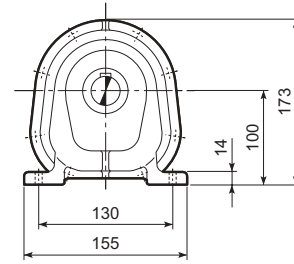
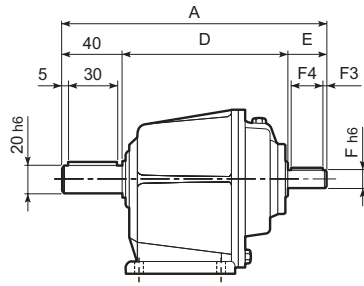
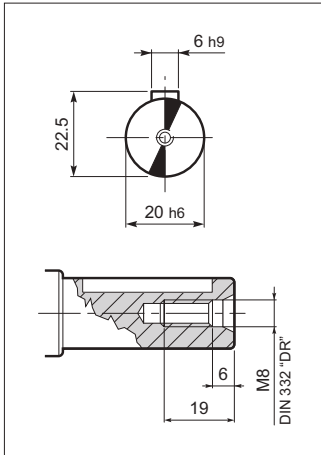

**P
DP**

INPUT

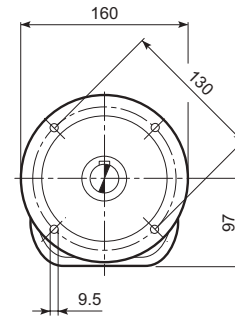
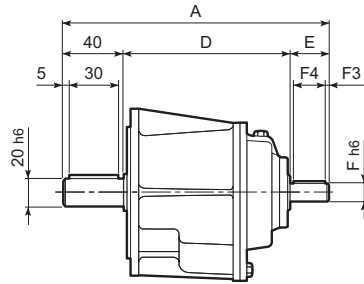
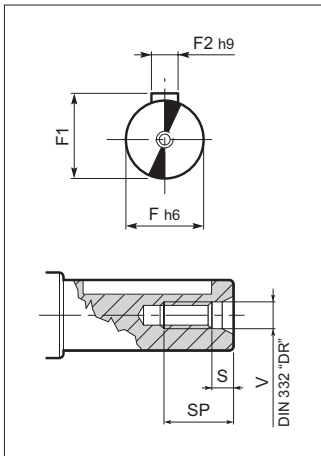

**F
DF**

	AS 20											
	A	D	E	F	F1	F2	F3	F4	V	S	SP	Kg
AS 20 P_HS	233	153	40	19	21.8	6	5	30	M6	5	16	6.4
AS 20 DP_HS	230	153	40	16	21.8	5	5	30	M6	5	16	6
AS 20 F_HS	233	153	40	19	21.8	6	5	30	M6	5	16	6.4
AS 20 DF_HS	230	153	40	16	18.8	5	5	30	M6	5	16	6

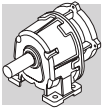

AS 25...P(IEC)

OUTPUT

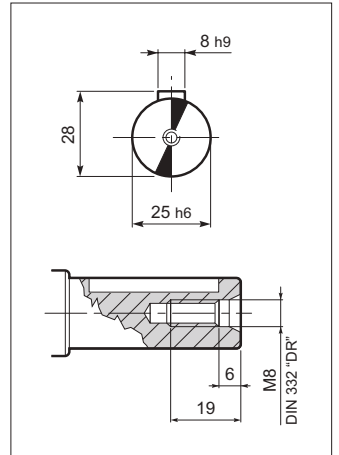

INPUT

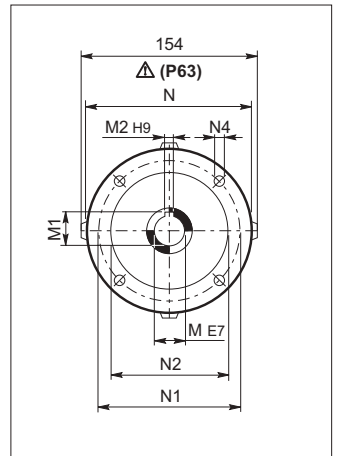

**P
DP**

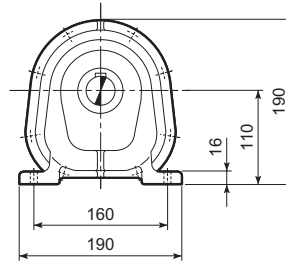
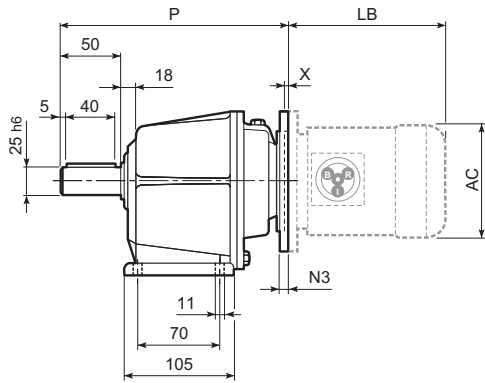

**F
DF**

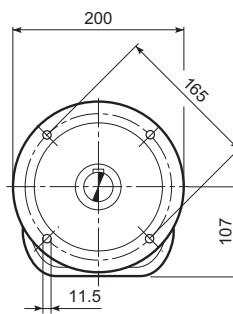
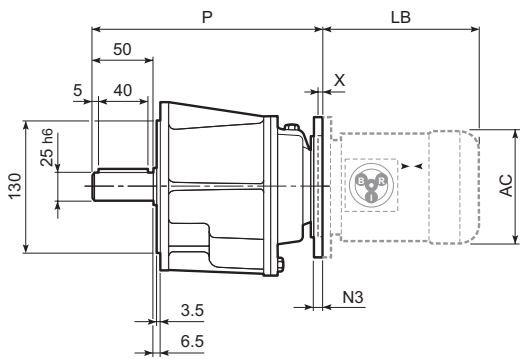

**R
DR**

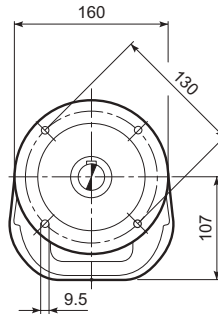
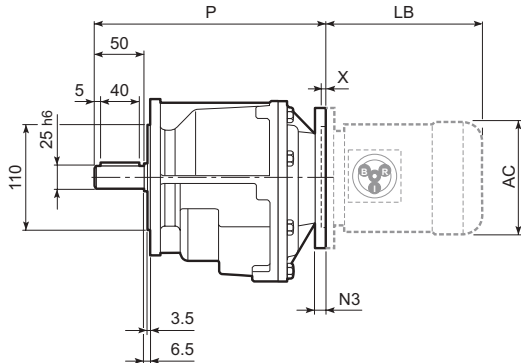

	AS 25												kg	IEC	BN...		BN...FD BN...FA		
	M	M1	M2	N	N1	N2	N3	N4	X	P					LB	AC	LB	AC	
P	...F	...R			
	AS 25_071	14	16.3	5	160	130	110	-	M8x16	5	214	214	242	14	BN 71	219	138	280	138
	AS 25_080	19	21.8	6	200	165	130	-	M10x12	5	219	219	247	14	BN 80	234	156	306	156
	AS 25_090	24	27.3	8	200	165	130	-	M10x12	5	219	219	247	14	BN 90	276	176	359	176
	AS 25 D_063	11	12.8	4	140	115	95	-	M8x19	3.5	214	194	242	13.5	BN 63	184	121	249	121
	AS 25 D_071	14	16.3	5	160	130	110	-	M8x16	3.5	214	194	242	13.5	BN 71	219	138	280	138

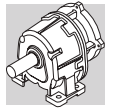

OUTPUT

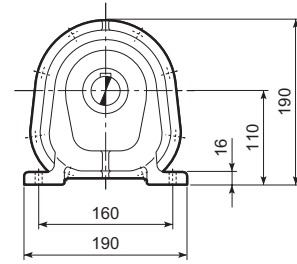
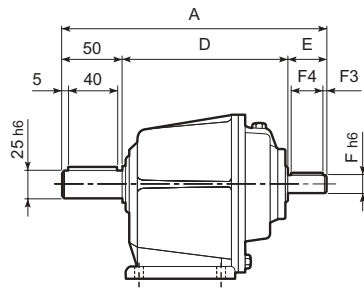
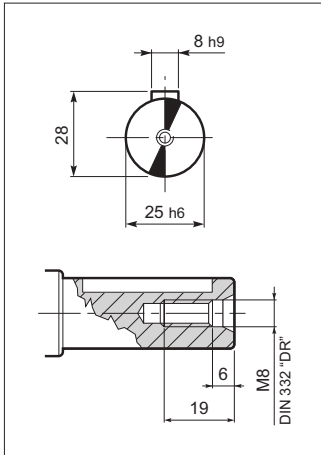

**P
DP**

INPUT

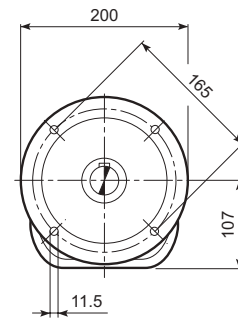
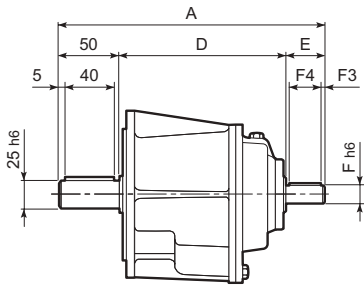
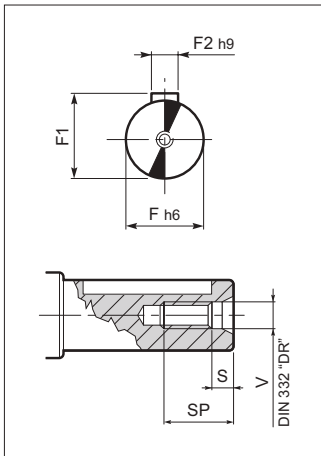

**F
DF**

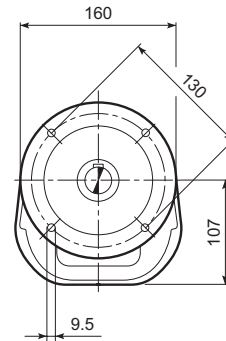
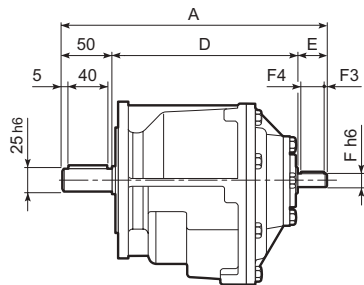

**R
DR**

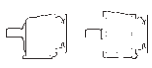
	AS 25											
	A	D	E	F	F1	F2	F3	F4	V	S	SP	
 AS 25 P_HS	252	162	40	19	21.8	5	5	30	M6	5	16	14
AS 25 DP_HS	250	160	40	16	18.8	5	5	30	M6	5	16	13.5
AS 25 F_HS	252	162	40	19	21.8	5	5	30	M6	5	16	14
AS 25 DF_HS	250	160	40	16	18.8	5	5	30	M6	5	16	13.5
AS 25 R_HS	280	190	40	19	21.8	5	5	30	M6	5	16	14
AS 25 DR_HS	278	188	40	16	18.8	5	5	30	M6	5	16	13.5

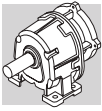

AS 30...P(IEC)

OUTPUT

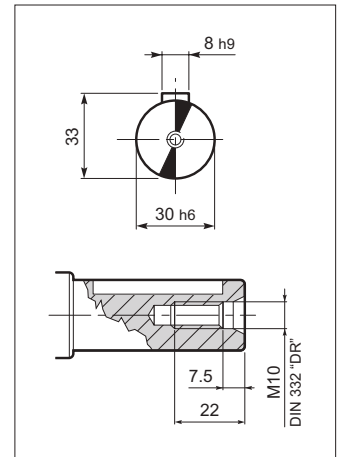

INPUT

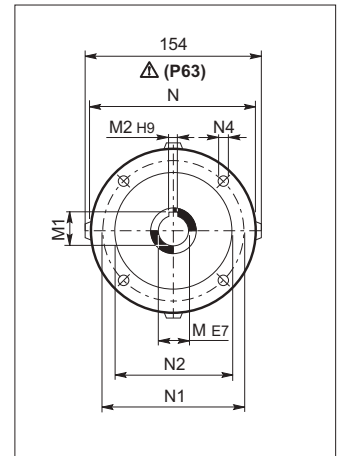

**P
DP**

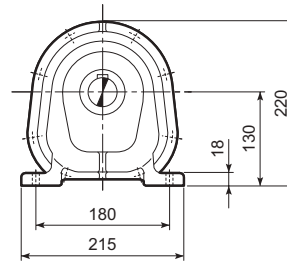
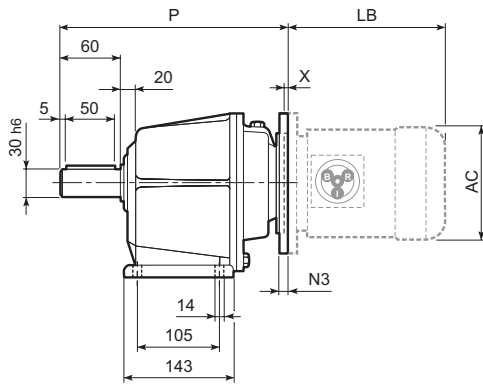

**F
DF**

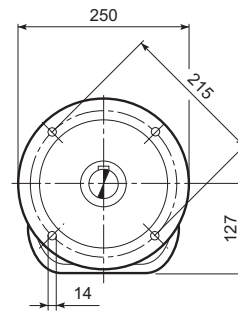
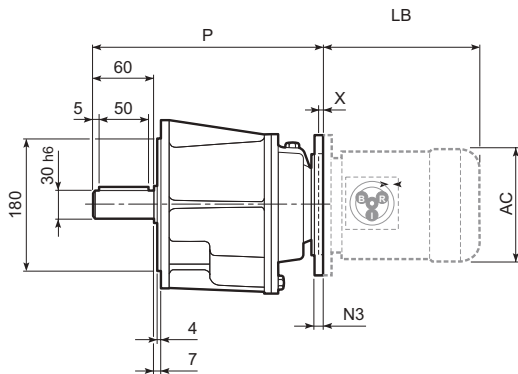

**R
DR**

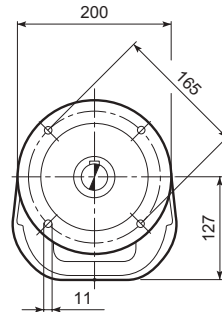
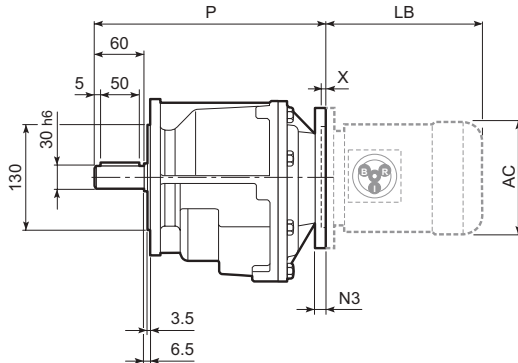

	AS 30													kg	[iec]	BN...		BN...FD BN...FA	
	M	M1	M2	N	N1	N2	N3	N4	X	P			LB			AC	LB	AC	
P	...F	...R							
	AS 30_071	14	16.3	5	160	130	110	-	M8x16	5	284	284	-	23	BN 71	219	138	280	138
	AS 30_080	19	21.8	6	200	165	130	-	M10x12	4	284	284	311	23	BN 80	234	156	306	156
	AS 30_090	24	27.3	8	200	165	130	-	M10x12	4	284	284	311	23	BN 90	276	176	359	176
	AS 30_100	28	31.3	8	250	215	180	-	M12x16	5	284	284	311	23	BN 100	307	195	398	195
	AS 30_112	28	31.3	8	250	215	180	-	M12x16	5	284	284	311	23	BN 112	325	219	424	219
	AS 30 D_071	14	16.3	5	160	130	110	-	M8x19	5	276	276	303	22.5	BN 71	219	138	280	138
	AS 30 D_080	19	21.8	6	200	165	130	-	M10x19	5	281	281	308	22.5	BN 80	234	156	306	156
	AS 30 D_090	24	27.3	8	200	165	130	-	M10x12	5	281	281	308	22.5	BN 90	276	176	359	176

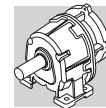

OUTPUT

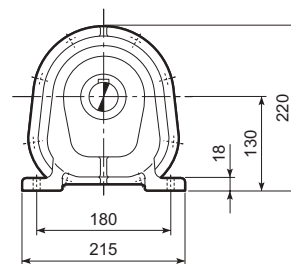
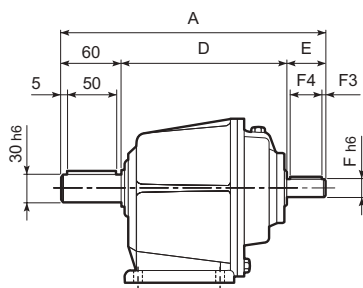
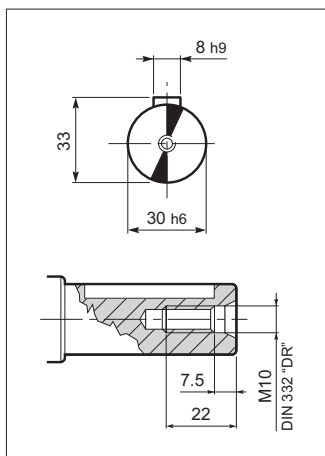

**P
DP**

INPUT

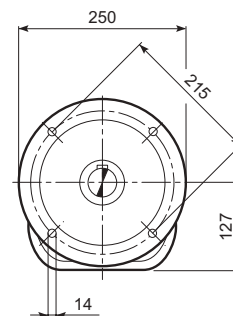
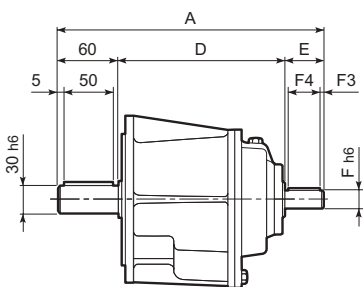
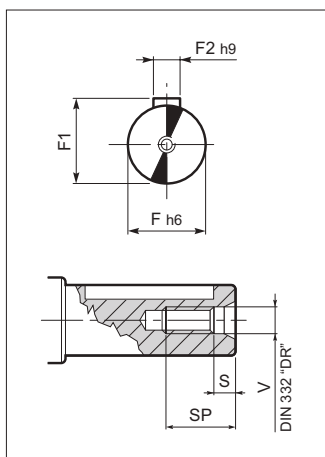

**F
DF**

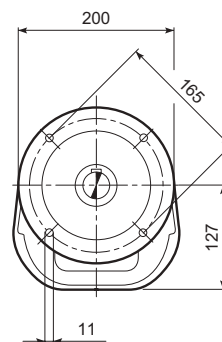
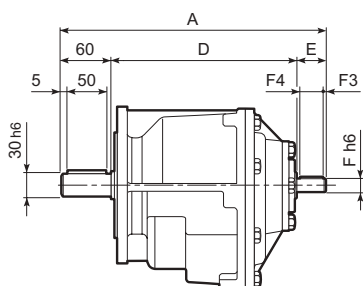

**R
DR**

	AS 30											
	A	D	E	F	F1	F2	F3	F4	V	S	SP	Kg
AS 30 P_HS	329	219	50	24	27.3	8	5	40	M8	6	19	23
AS 30 DP_HS	314	214	40	19	21.8	6	5	30	M6	5	16	22.5
AS 30 F_HS	329	219	50	24	27.3	8	5	40	M8	6	19	24
AS 30 DF_HS	314	214	40	19	21.8	6	5	30	M6	5	16	23.5
AS 30 R_HS	356	246	50	24	27.3	8	5	40	M8	6	19	22.5
AS 30 DR_HS	341	241	40	19	21.8	6	5	30	M6	5	16	23.5

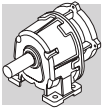

AS 35...P(IEC)

OUTPUT

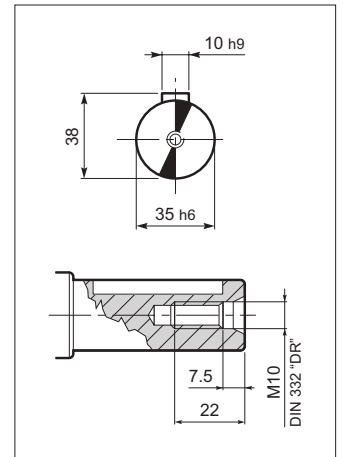

INPUT

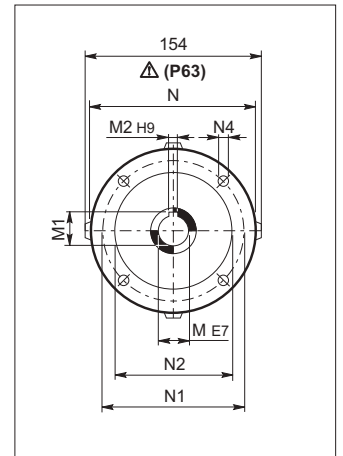

**P
DP**

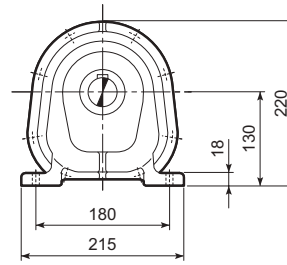
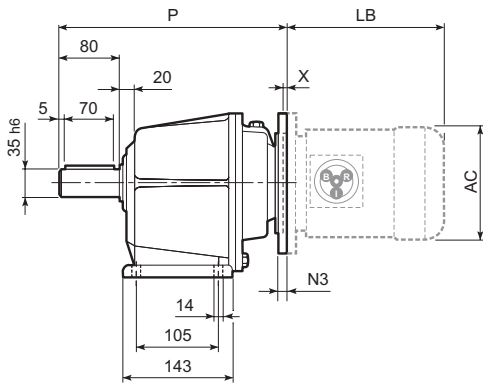

**F
DF**

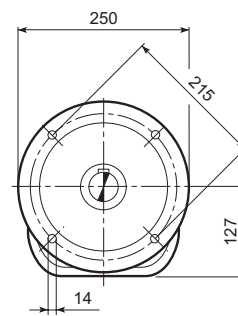
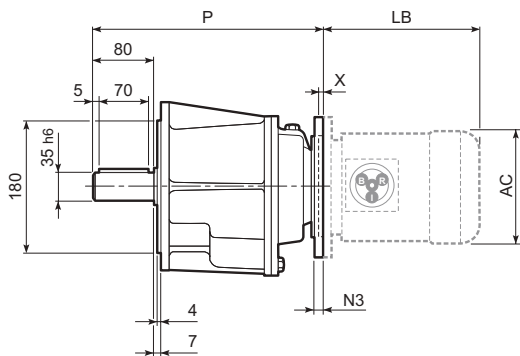

**R
DR**

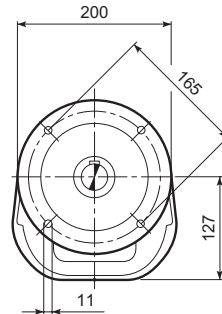
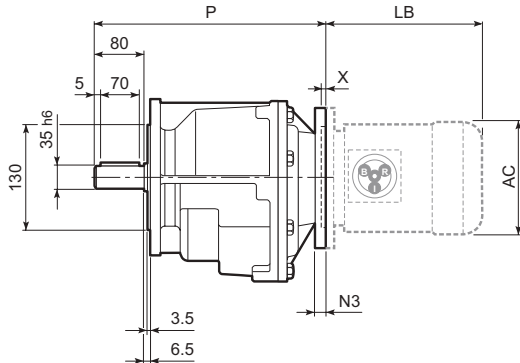

	AS 35													BN...		BN...FD BN...FA			
	M	M1	M2	N	N1	N2	N3	N4	X	P			Kg	[IEC]	LB	AC	LB	AC	
	...P	...F	...R																
	AS 35_071	14	16.3	5	160	130	110	-	M8x16	5	304	304	-	24	BN 71	219	138	280	138
	AS 35_080	19	21.8	6	200	165	130	-	M10x12	4	304	304	331	24	BN 80	234	156	306	156
	AS 35_090	24	27.3	8	200	165	130	-	M10x12	4	304	304	331	24	BN 90	276	176	359	176
	AS 35_100	28	31.3	8	250	215	180	-	M12x16	5	304	304	-	24	BN 100	307	195	398	195
	AS 35_112	28	31.3	8	250	215	180	-	M12x16	5	304	304	-	24	BN 112	325	219	424	219
	AS 35 D_071	14	16.3	5	160	130	110	-	M8x19	5	296	296	323	23.5	BN 71	219	138	280	138
	AS 35 D_080	19	21.8	6	200	165	130	-	M10x19	5	301	301	328	23.5	BN 80	234	156	306	156
	AS 35 D_090	24	27.3	8	200	165	130	-	M10x12	5	301	301	328	23.5	BN 90	276	176	359	176

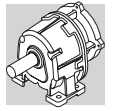

OUTPUT

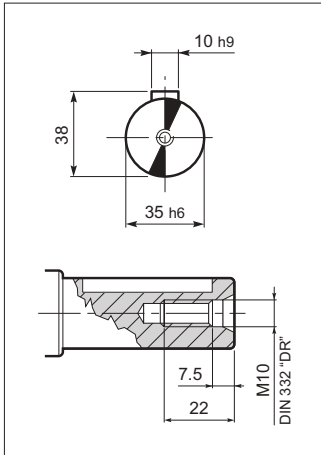

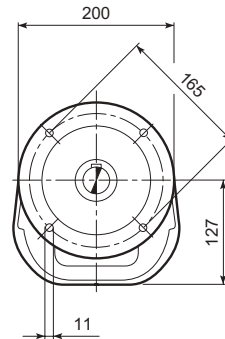
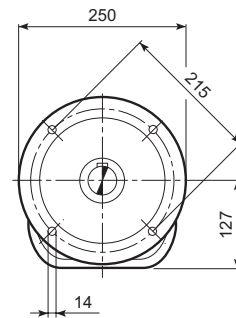
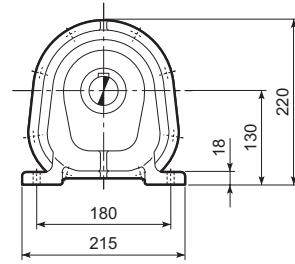
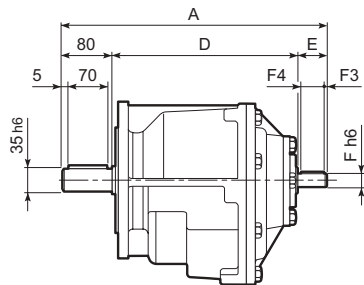
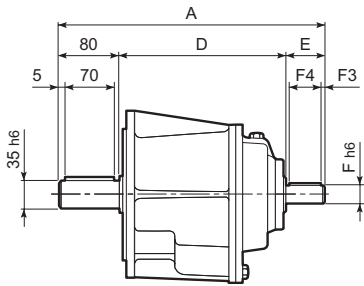
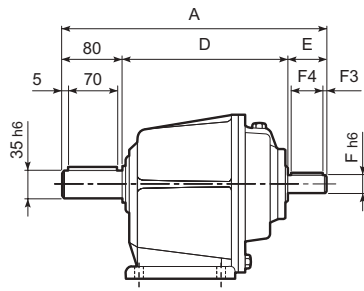
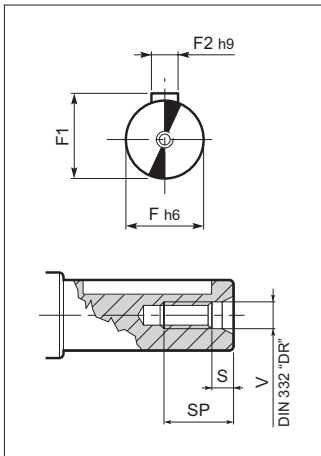

INPUT



**P
DP**

**F
DF**

**R
DR**

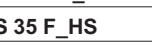
	AS 35											
	A	D	E	F	F1	F2	F3	F4	V	S	SP	
 AS 35 P_HS	349	219	50	24	27.3	8	5	40	M8	6	19	24
AS 35 DP_HS	334	214	40	19	21.8	6	5	30	M6	5	16	23.5
 AS 35 F_HS	349	219	50	24	27.3	8	5	40	M8	6	19	24
AS 35 DF_HS	334	214	40	19	21.8	6	5	30	M6	5	16	23.5
AS 35 R_HS	376	246	50	24	27.3	8	5	40	M8	6	19	23.5
AS 35 DR_HS	361	241	40	19	21.8	6	5	30	M6	5	16	23

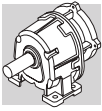

AS 45...P(IEC)

OUTPUT

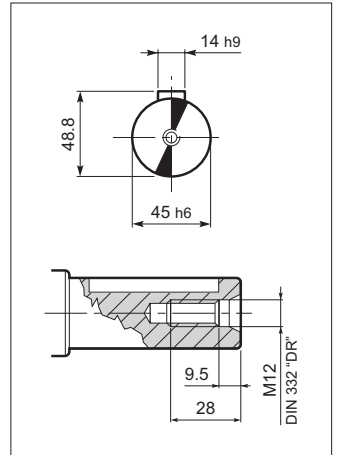

INPUT

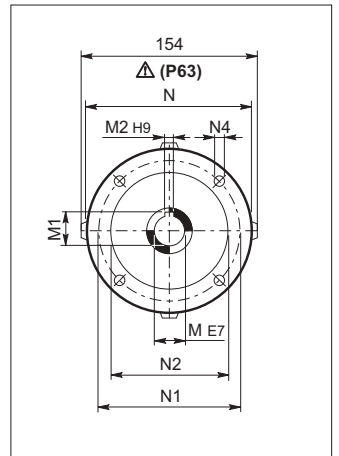

P
DP

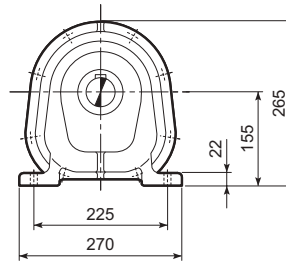
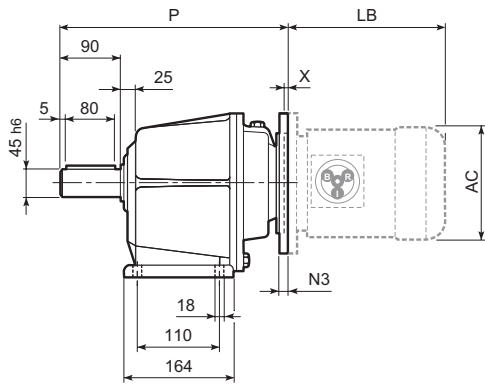

F
DF

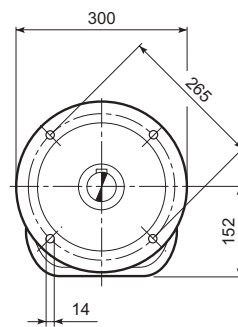
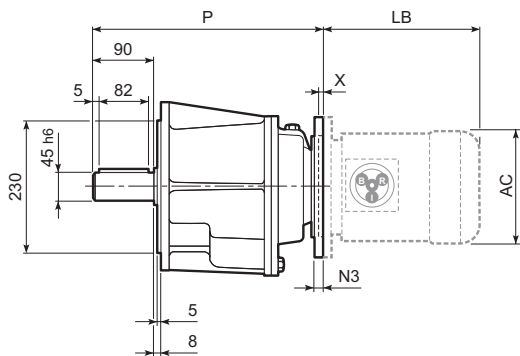

	AS 45													BN...		BN...FD BN...FA			
	M	M1	M2	N	N1	N2	N3	N4	X	P			Kg	IEC	LB	AC	LB	AC	
										...P	...F	...R							
	AS 45_090	24	27.3	8	200	165	130	-	M10x12	4	340	340	-	40	BN 90	276	176	359	176
	AS 45_100	28	31.3	8	250	215	180	-	M12x16	5	340	340	-	40	BN 100	307	195	398	195
	AS 45_112	28	31.3	8	250	215	180	-	M12x16	5	340	340	-	40	BN 112	325	219	424	219
	AS 45_132	38	41.3	10	300	265	230	14	M12x16	5	360	360	-	40	BN 132	413	258	523	258
	AS 45 D_071	14	16.3	5	160	130	110	-	M8x19	5	350	350	-	35	BN 71	219	138	280	138
	AS 45 D_080	19	21.8	6	200	165	130	-	M10x19	5	350	350	-	35	BN 80	234	156	306	156
	AS 45 D_090	24	27.3	8	200	165	130	-	M10x20	5	350	350	-	35	BN 90	276	176	359	176
	AS 45 D_100	28	31.3	8	250	215	180	-	M12x16	5	350	350	-	35	BN 100	307	195	398	195
	AS 45 D_112	28	31.3	8	250	215	100	-	M12x16	5	350	350	-	35	BN 112	325	219	424	219

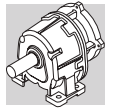

OUTPUT

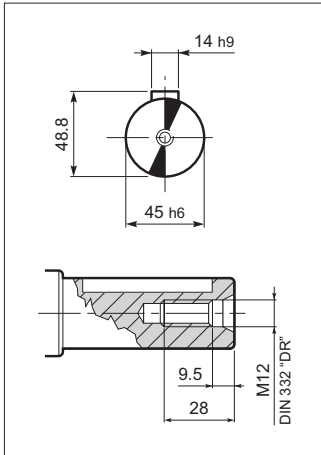

INPUT

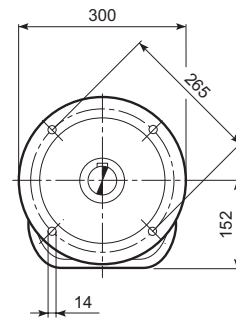
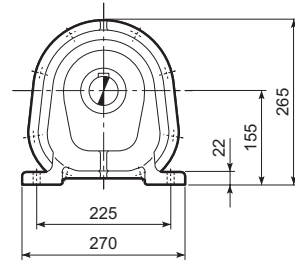
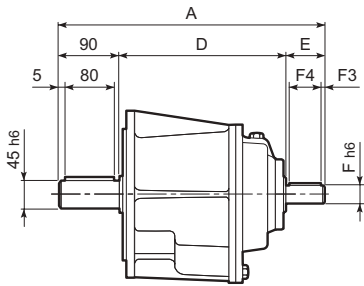
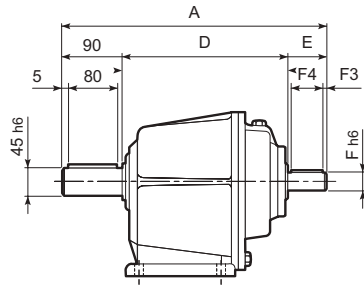
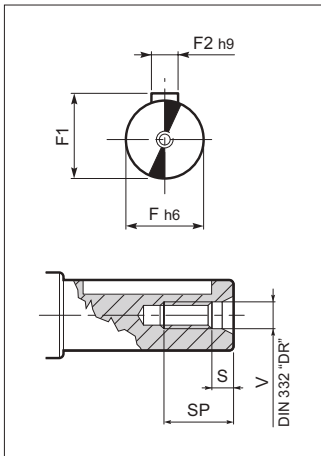

**P
DP**

**F
DF**

	AS 45											
	A	D	E	F	F1	F2	F3	F4	V	S	SP	Kg
AS 45 P_HS	392	245	60	28	31.3	8	5	50	M10	7.5	22	40
AS 45 DP_HS	395	255	50	24	27.3	8	5	40	M8	6	19	35
AS 45 F_HS	392	245	60	28	31.3	8	5	50	M10	7.5	22	40
AS 45 DF_HS	395	255	50	24	27.3	8	5	40	M8	6	19	35

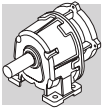

AS 55...P(IEC)

OUTPUT

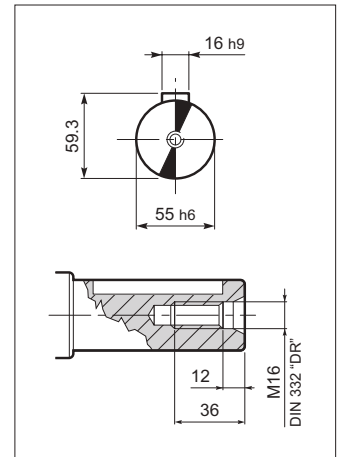

INPUT

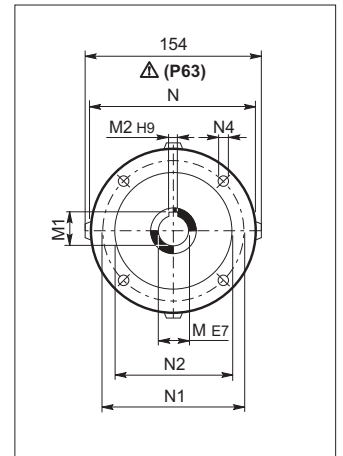

P
DP

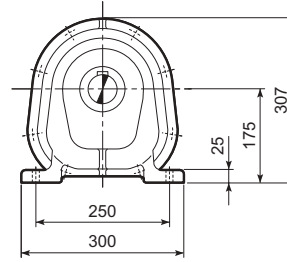
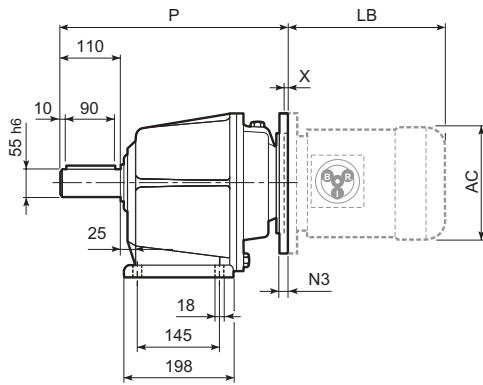

F
DF

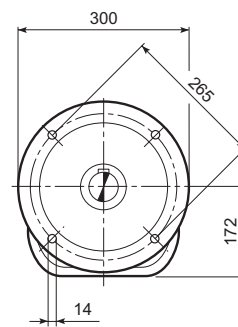
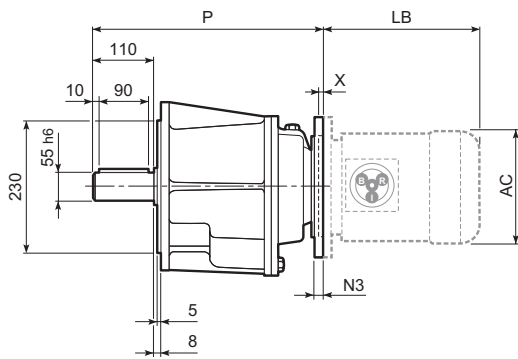

	AS 55													kg	IEC	BN...		BN...FD BN...FA	
	M	M1	M2	N	N1	N2	N3	N4	X	P			LB			AC	LB	AC	
										...P	...F	...R							
	AS 55_100	28	31.3	8	250	215	180	-	M12x16	5	430	430	-	61	BN 100	307	195	398	195
	AS 55_112	28	31.3	8	250	215	180	-	M12x16	5	430	430	-	61	BN 112	325	219	424	219
	AS 55_132	38	41.3	10	300	265	230	16	14	5	460	460	-	61	BN 132	413	258	523	258
	AS 55_160	42	45.3	12	350	300	250	23	18	6	460	460	-	61	BN 160MR	452	258	562	258
															BN 160M/L	486	310	626	310
	AS 55 D_080	19	21.8	6	200	165	130	-	M10x19	4	418	418	-	56	BN 80	234	156	306	156
	AS 55 D_090	24	27.3	8	200	165	130	-	M10x20	4	418	418	-	56	BN 90	276	176	359	176
	AS 55 D_100	28	31.3	8	250	215	180	-	M12x16	5	418	418	-	56	BN 100	307	195	398	195
	AS 55 D_112	28	31.3	8	250	215	180	-	M12x16	5	438	438	-	56	BN 112	325	219	424	219
	AS 55 D_132	38	41.3	10	300	265	230	16	14	5	438	438	-	56	BN 132	413	258	523	258

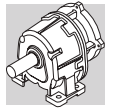

OUTPUT

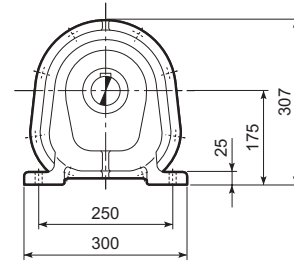
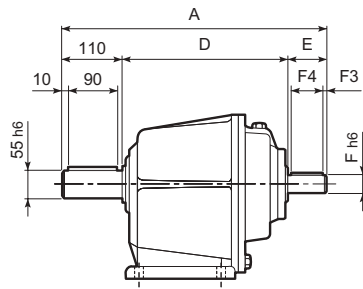
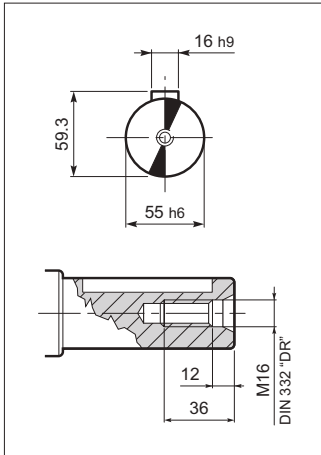

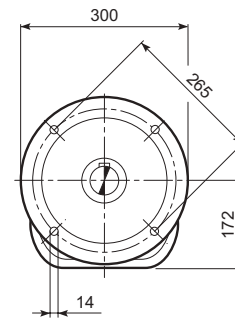
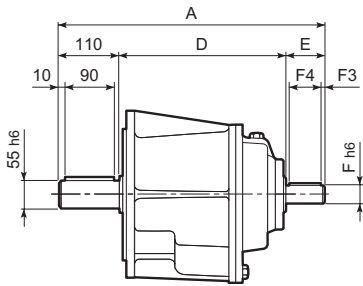
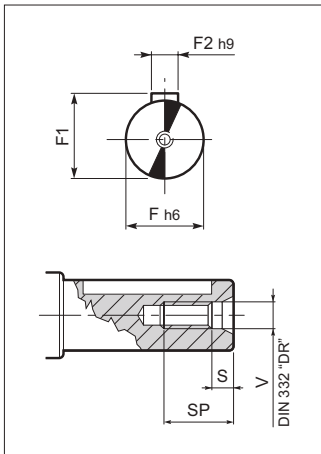

**P
DP**

INPUT

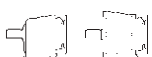
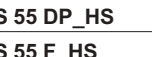

**F
DF**

	AS 55											
	A	D	E	F	F1	F2	F3	F4	V	S	SP	
 AS 55 P_HS	505	315	80	38	41.3	10	10	60	M12	9.5	28	61
 AS 55 DP_HS	475	305	60	28	31.3	8	5	50	M10	7.5	22	56
 AS 55 F_HS	505	315	80	38	41.3	10	10	60	M12	9.5	28	61
 AS 55 DF_HS	475	305	60	28	31.3	8	5	50	M10	7.5	22	56

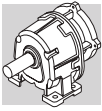

AS 60...P(IEC)

OUTPUT

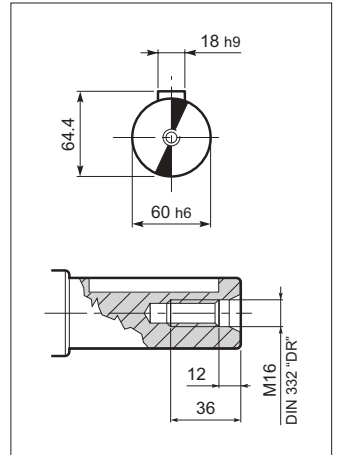

INPUT

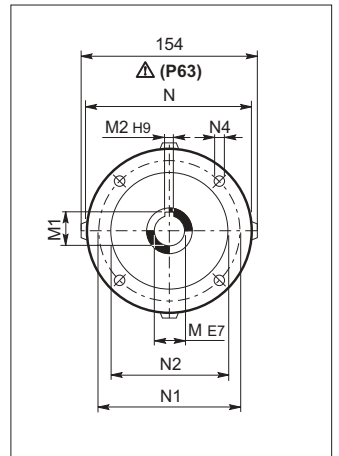

P
DP

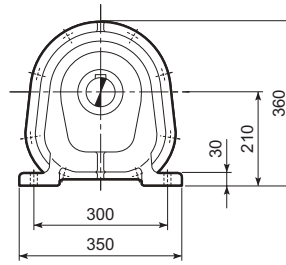
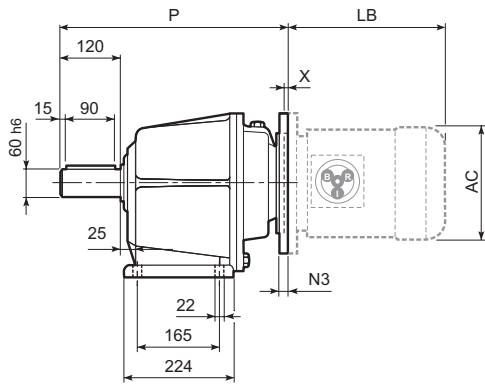

F
DF

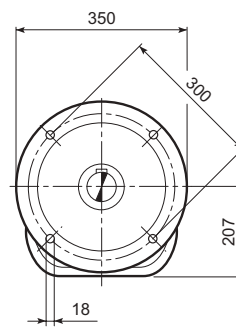
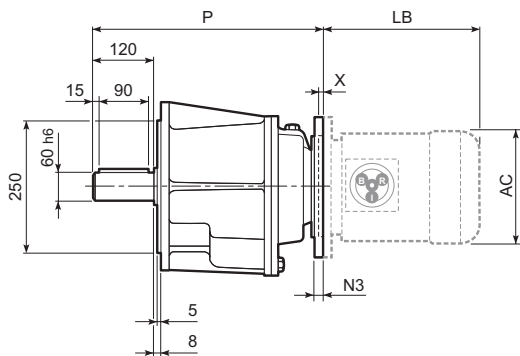

	AS 60													BN...		BN...FD BN...FA		
	M	M1	M2	N	N1	N2	N3	N4	X	P			Kg	[img alt="IEC logo"]	LB	AC	LB	AC
										...P	...F	...R						
AS 60_132	38	41.3	10	300	265	230	16	14	5	470	470	-	91	BN 132	413	258	523	258
AS 60_160	42	45.3	12	350	300	250	23	18	5	495	495	-	91	BN 160MR	452	258	562	258
														BN 160M/L	486	310	626	310
AS 60_180	48	51.8	14	350	300	250	23	18	6	495	495	-	91	BN 180M	530	310	670	310
														BN 180L	598	348	756	348
AS 60 D_080	19	21.8	6	200	165	130	-	M10x19	4	457	457	-	86	BN 80	234	156	306	156
AS 60 D_090	24	27.3	8	200	165	130	-	M10x20	4	457	457	-	86	BN 90	276	176	359	176
AS 60 D_100	28	31.3	8	250	215	180	-	M12x16	5	457	457	-	86	BN 100	307	195	398	195
AS 60 D_112	28	31.3	8	250	215	180	-	M12x16	5	457	457	-	86	BN 112	325	219	424	219
AS 60 D_132	38	41.3	10	300	265	230	16	14	5	477	477	-	86	BN 132	413	258	523	258

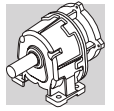

OUTPUT

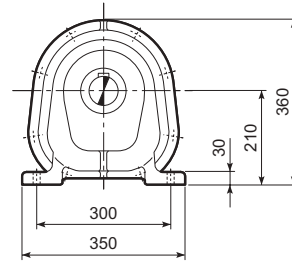
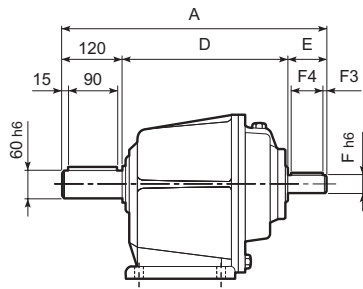
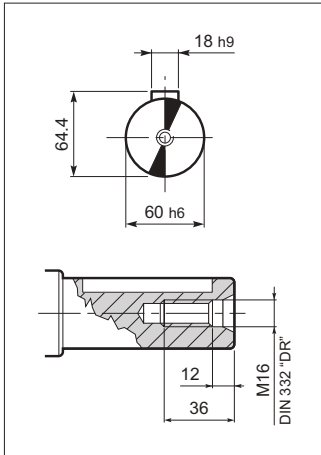

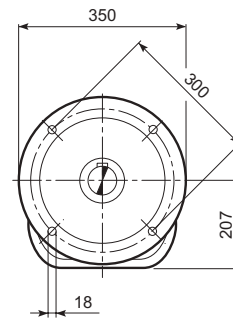
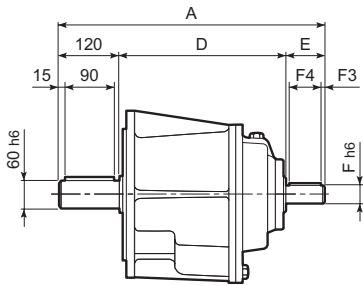
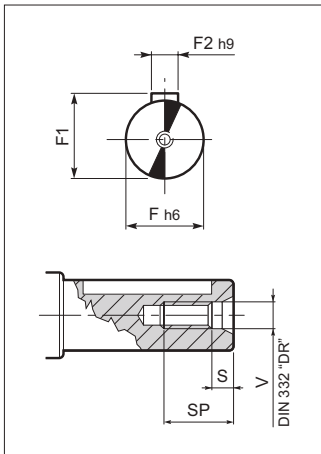

**P
DP**

INPUT

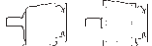
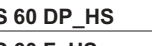
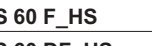

**F
DF**

	AS 60											
	A	D	E	F	F1	F2	F3	F4	V	S	SP	
 AS 60 P_HS	575	345	110	42	45.3	12	10	90	M12	9.5	28	91
 AS 60 DP_HS	535	335	80	38	41.3	10	10	60	M12	9.5	28	86
 AS 60 F_HS	575	345	110	42	45.3	12	10	90	M12	9.5	28	91
 AS 60 DF_HS	535	335	80	38	41.3	10	10	60	M12	9.5	28	86

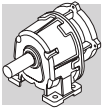

AS 80...P(IEC)

OUTPUT

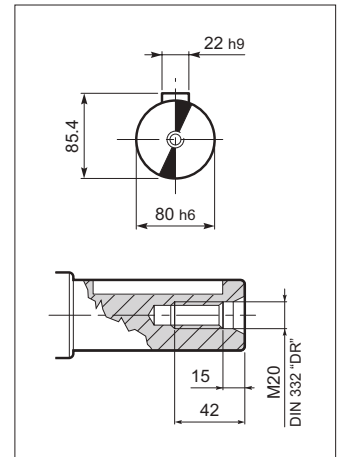

INPUT

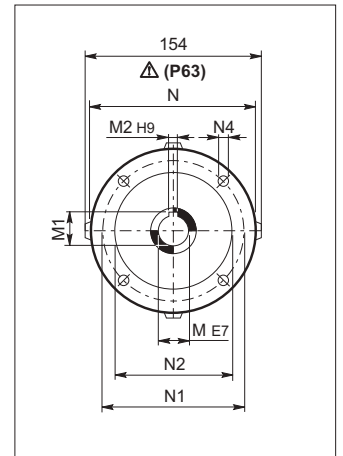

**P
DP**

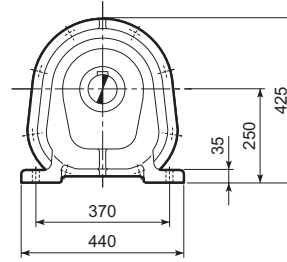
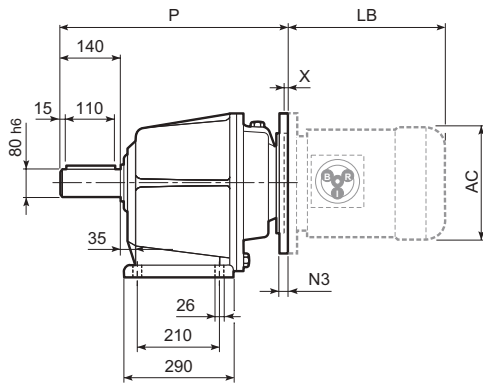

**F
DF**

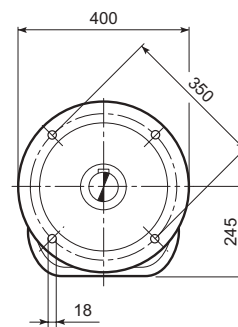
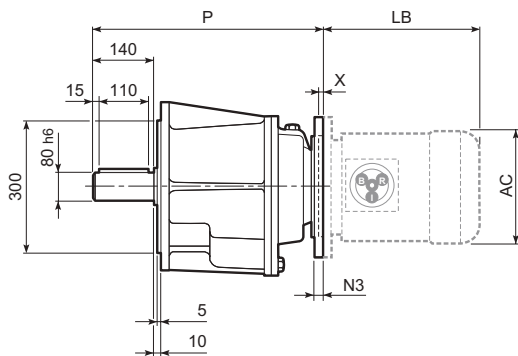

	AS 80													BN...		BN...FD BN...FA		
	M	M1	M2	N	N1	N2	N3	N4	X	P			Kg	[img alt="Motor icon"]	LB	AC	LB	AC
										...P	...F	...R						
AS 80_160	42	45.3	12	350	300	250	23	18	6	600	600	-	152	BN 160MR	452	258	562	258
														BN 160M/L	486	310	626	310
AS 80_180	48	51.8	14	350	300	250	23	18	6	600	600	-	152	BN 180M	530	310	670	310
														BN 180L	598	348	756	348
AS 80_200	55	59.3	16	400	350	300	-	M16x25	6	600	600	-	152	BN 200L	612	348	768	348
AS 80 D_100	28	31.3	8	250	215	180	-	M12x16	5	585	585	-	147	BN 100	307	195	398	195
AS 80 D_112	28	31.3	8	250	215	180	-	M12x16	5	585	585	-	147	BN 112	325	219	424	219
AS 80 D_132	38	41.3	10	300	265	230	16	14	5	615	615	-	147	BN 132	413	258	523	258
AS 80 D_160	42	45.3	12	350	300	250	23	18	5	615	615	-	147	BN 160MR	452	258	562	258
														BN 160M/L	486	310	626	310

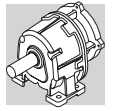

OUTPUT

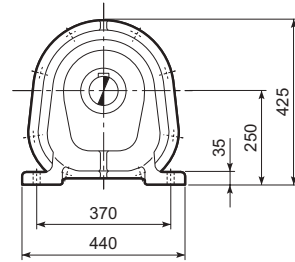
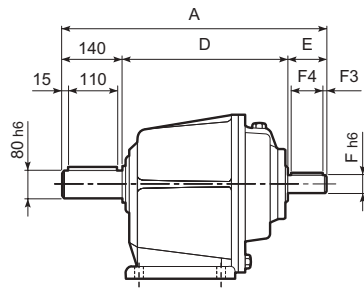
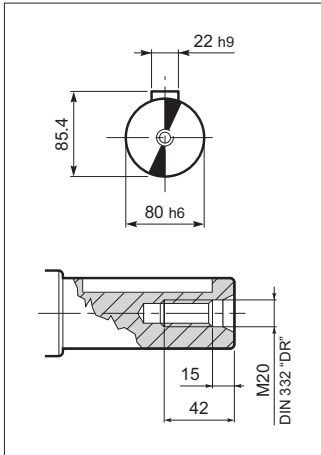

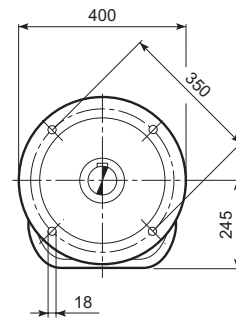
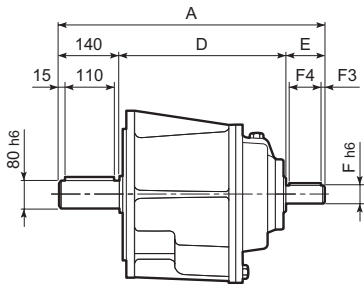
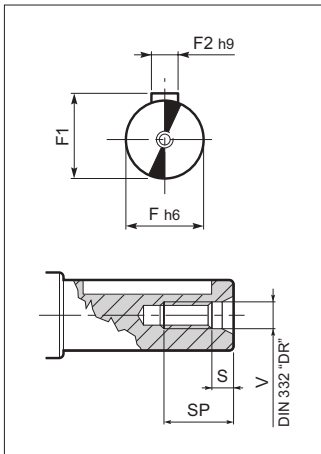

**P
DP**

INPUT

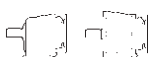
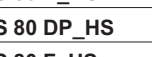
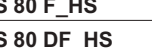

**F
DF**

	AS 80											
	A	D	E	F	F1	F2	F3	F4	V	S	SP	
 AS 80 P_HS	705	455	110	48	51.8	14	10	90	M16	12	36	152
 AS 80 DP_HS	690	440	110	42	45.3	12	10	90	M12	9.5	28	147
 AS 80 F_HS	705	455	110	48	51.8	14	10	90	M16	12	36	152
 AS 80 DF_HS	690	440	110	42	45.3	12	10	90	M12	9.5	28	147

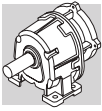

AS 90...P(IEC)

OUTPUT

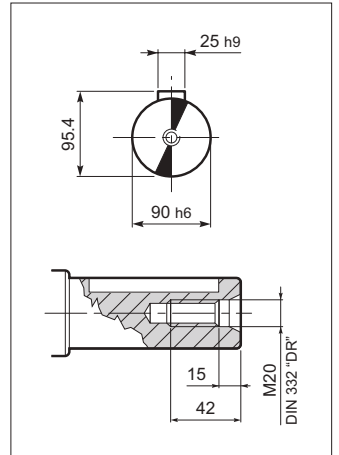

INPUT

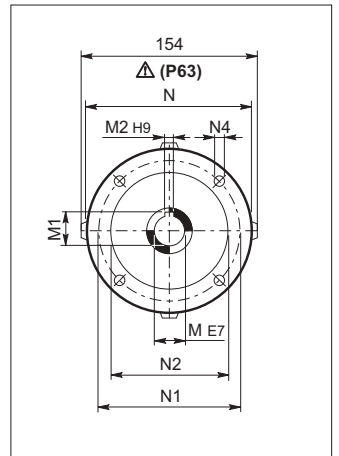

**P
DP**

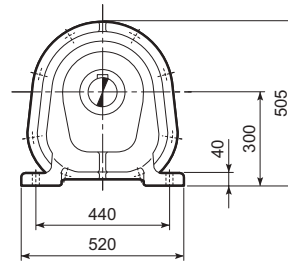
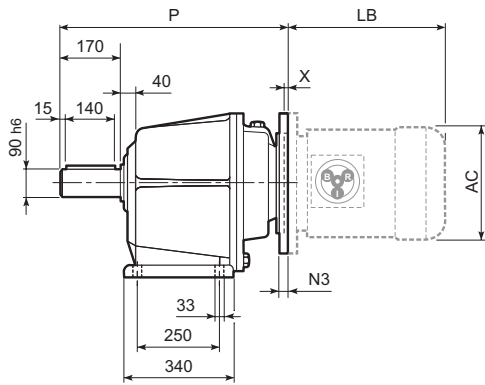

**F
DF**

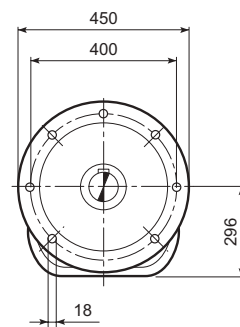
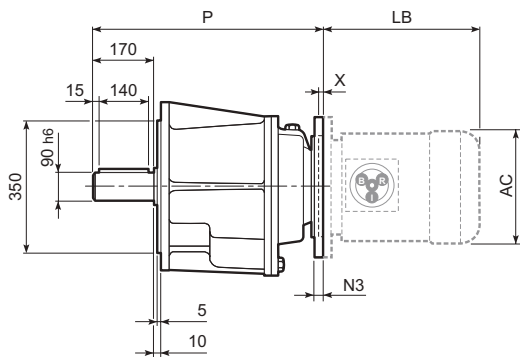

	AS 90													BN...		BN...FD BN...FA		
	M	M1	M2	N	N1	N2	N3	N4	X	P			Kg	[Motor Icon]	LB	AC	LB	AC
										...P	...F	...R						
AS 90_180	48	51.8	14	350	300	250	23	18	6	685	685	-	239	BN 180M	530	310	670	310
														BN 180L	598	348	756	348
AS 90_200	55	59.3	16	400	350	300	-	M16x25	6	685	685	-	239	BN 200L	612	348	768	348
AS 90_225	60	64.4	18	450	400	350	25	18	6	710	710	-	239	-	-	-	-	-
AS 90 D_100	28	31.3	8	250	215	180	-	M12x16	5	664	664	-	232	BN 100	307	195	398	195
AS 90 D_112	28	31.3	8	250	215	180	-	M12x16	5	664	664	-	232	BN 112	325	219	424	219
AS 90 D_132	38	41.3	10	300	265	230	16	14	5	689	689	-	232	BN 132	413	258	523	258
AS 90 D_160	42	45.3	12	350	300	250	23	18	5	689	689	-	232	BN 160MR	452	258	562	258
														BN 160M/L	486	310	626	310
AS 90 D_180	48	51.8	14	350	300	250	23	18	5	689	689	-	232	BN 180M	530	310	670	310
														BN 180L	598	348	756	348

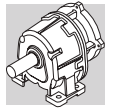

OUTPUT

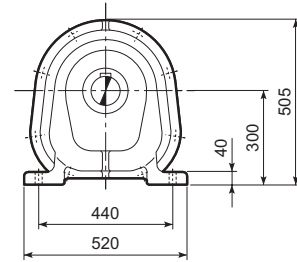
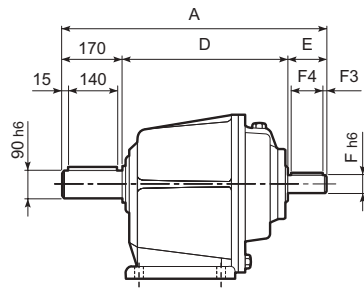
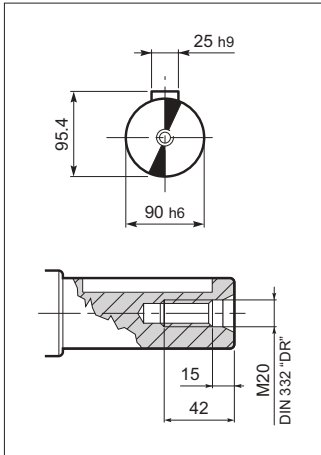

**P
DP**

INPUT

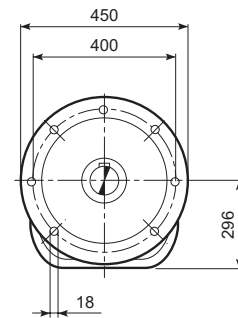
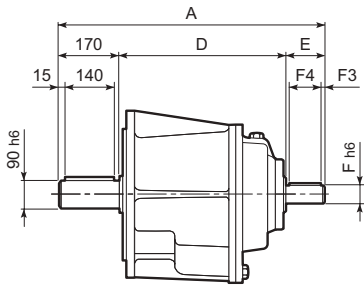
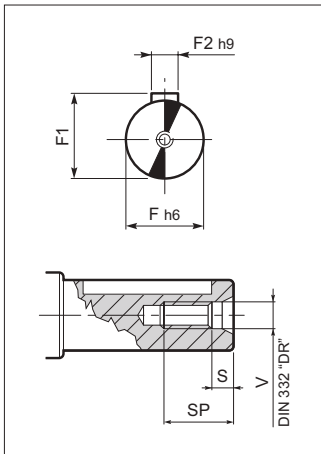

**F
DF**

	AS 90											
	A	D	E	F	F1	F2	F3	F4	V	S	SP	Kg
AS 90 P_HS	787	507	110	55	59.3	16	10	90	M16	12	36	239
AS 90 DP_HS	770	490	110	48	53.8	14	10	90	M16	12	36	232
AS 90 F_HS	787	507	110	55	59.3	16	10	90	M16	12	36	239
AS 90 DF_HS	770	490	110	48	53.8	14	10	90	M16	12	36	232

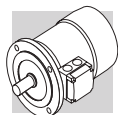

SIMBOLOGIA E UNITÀ DI MISURA		SYMBOLS AND UNITS OF MEASURE		SYMBOLS UND MAßEINHEITEN		SYMBOLS ET UNITES DE MESURE	
Symb.	U.m.	Descrizione	Description	Beschreibung	Description	Symb.	U.m.
$\cos\phi$	–	Fattore di potenza	Power factor	Leistungsfaktor	Facteur de puissance		
η	–	Rendimento	Efficiency	Wirkungsgrad	Rendement		
f_m	–	Fattore correttivo della potenza	Power adjusting factor	Leistungskorrekturfaktor	Facteur de correction de la puissance		
I	–	Rapporto di intermittenza	Cyclic duration factor	Relative Einschaltdauer	Rapport d'intermittence		
I_N	[A]	Corrente nominale	Rated current	Nennstrom	Courant nominal		
I_S	[A]	Corrente di spunto	Locked rotor current	Kurzschlußstrom	Courant de démarrage		
J_C	[Kgm ²]	Momento di inerzia del carico	Load moment of inertia	Massenträgheitsmoment der externen Massen	Moment d'inertie de la charge		
J_M	[Kgm ²]	Momento di inerzia motore	Moment of inertia	Trägheitsmoment	Moment d'inertie du moteur		
K_c	–	Fattore di coppia	Torque factor	Drehmomentfaktor	Facteur de couple		
K_d	–	Fattore di carico	Load factor	Lastfaktor	Facteur de charge		
K_J	–	Fattore di inerzia	Inertia factor	Trägheitsfaktor	Facteur d'inertie		
M_A	[Nm]	Coppia accelerante media	Mean breakaway torque	Losbrechmoment	Couple d'accélération moyen		
M_B	[Nm]	Coppia frenante	Brake torque	Bremsemoment	Couple du frein		
M_N	[Nm]	Coppia nominale	Rated torque	Nennmoment	Couple nominal		
M_L	[Nm]	Coppia resistente media	Counter-torque during acceleration	Lastmoment	Couple résistant moyen		
M_S	[Nm]	Coppia di spunto	Starting torque	Startmoment	Couple de démarrage		
n	[min ⁻¹]	Velocità nominale	Rated speed	Nendrehzahl	Vitesse nominale		
P_B	[W]	Potenza assorbita dal freno a 20°C	Power drawn by the brake at 20°C	Leistungsaufnahme der Bremse bei 20°C	Puissance absorbée par le frein à 20°C		
P_n	[kW]	Potenza nominale	Motor rated power	Nennleistung	Puissance nominale		
P_r	[kW]	Potenza richiesta	Required power	Benötigte Leistung	Puissance nécessaire		
t_1	[ms]	Ritardo di sblocco del freno con alimentatore a semionda	Brake response time with one-way rectifier	Ansprechzeit Bremse mit Einweg-Gleichrichter	Temps de déblocage du frein avec alimentation à demi-onde		
t_{1s}	[ms]	Tempo di sblocco del freno con alimentatore a controllo elettronico	Brake response time with electronic-controlled rectifier	Ansprechzeit Bremse mit elektronisch gesteuertem Gleichrichter	Temps de déblocage du frein avec alimentation à contrôle électronique		
t_2	[ms]	Ritardo di frenatura con disgiunzione lato c.a.	Brake reaction time with a.c. disconnect	Einfallszeit Bremse bei Unterbrechung der Stromversorgung WS	Retard de freinage avec coupure coté c.a.		
t_{2c}	[ms]	Ritardo di frenatura con disgiunzione circuito c.a. e c.c.	Brake reaction time with a.c. and d.c. disconnect	Einfallszeit Bremse bei Unterbrechung der Stromversorgung WS und GS	Retard de freinage avec coupure coté c.a. et c.c.		
t_a	[°C]	Temperatura ambiente	Ambient temperature	Umgebungstemperatur	Température ambiante		
t_f	[min]	Tempo di funzionamento a carico costante	Work time at constant load	Betriebsdauer unter Nennbelastung	Temps de fonctionnement à charge constante		
t_r	[min]	Tempo di riposo	Rest time	Aussetzzeit	Temps de repos		
W	[J]	Lavoro di frenatura accumulato tra due regolazioni del traferro	Braking work between service	Bremsenergie zwischen zwei Einstellungen	Energie de freinage accumulée entre deux réglages de l'entrefer		
W_{max}	[J]	Energia massima per singola frenatura	Maximum brake work for each braking	Max. Bremsarbeit pro Bremsvorgang	Energie maxi par freinage		
Z	[1/h]	N° di avviamenti ammissibili, a carico	Permissible starting frequency, loaded	Schalhäufigkeit Nennbetrieb	Nombre de démarrages admissibles en charge		
Z_0	[1/h]	N° di avviamenti ammissibili a vuoto (I = 50%)	Max. permissible no-load starting frequency (I = 50%)	Max. Schalhäufigkeit im Leerlauf (relative Einschalt-dauer I = 50%)	Nombre de démarrages admissible à vide (I = 50%)		

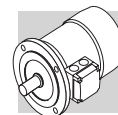

M1 - PROGRAMMA DI PRODUZIONE

Questo catalogo descrive i motori asincroni trifase in bassa tensione di produzione BONFIGLIOLI RIDUTTORI.

I motori sono del tipo chiuso con ventilazione esterna e rotore a gabbia per l'utilizzo in ambienti industriali.

M1 - PRODUCTION PLANNING

This catalogue discusses low-voltage three-phase asynchronous motors manufactured by BONFIGLIOLI RIDUTTORI.

Motors are the enclosed type with outer fan and cage-type rotor for use in industrial environments.

M1 - PRODUKTIONSPROGRAMM

In diesem Katalog werden die unter Niederspannung arbeitenden asynchronen Drehstrommotoren der Produktion von BONFIGLIOLI RIDUTTORI näher beschrieben. Hierbei handelt es sich um geschlossene Motoren mit Eigenbelüftung und einem Käfigrotor für den industriellen Einsatz.

M1 - PROGRAMME DE PRODUCTION

Ce catalogue décrit les moteurs asynchrones triphasés en basse tension produits par BONFIGLIOLI RIDUTTORI.

Les moteurs sont du type fermé avec ventilation extérieure et rotor à cage pour l'utilisation dans des milieux industriels.

M2 - NORMATIVE

I motori sono costruiti in accordo alle Norme CEI/EN ed IEC applicabili, riportate in tabella.

M2 - REFERENCE STANDARDS

Motors are manufactured in accordance with applicable CEI /EN and IEC standards, listed in the table.

M2 - NORMEN

Die Motoren wurden in entsprechender Normen CEI /EN und IEC, die in der nachstehenden Tabelle angegeben sind, gefertigt:

M2 - NORMES

Les moteurs sont fabriqués dans le respect des Normes CEI /EN et IEC applicables indiquées dans le tableau.

(01)

Titolo / Title / Titel / Titre	CEI	IEC
Prescrizioni generali per macchine elettriche rotanti <i>General requirements for rotating electrical machines</i> Allgemeine Vorschriften für umlaufende elektrische Maschinen <i>Prescriptions générales pour machines électriques tournantes</i>	CEI EN 60034-1	IEC 60034-1
Marchatura dei terminali e senso di rotazione per macchine elettriche rotanti <i>Terminal markings and direction of rotation of rotating machines</i> Kennzeichnung der Anschlußklemmen und Drehrichtung von umlaufenden elektrischen Maschinen <i>Définitions des bornes et sens de rotation pour machines électriques tournantes</i>	CEI 2-8	IEC 60034-8
Metodi di raffreddamento delle macchine elettriche <i>Methods of cooling for electrical machines</i> Verfahren zur Kühlung von elektrischen Maschinen <i>Méthodes de refroidissement des machines électriques</i>	CEI EN 60034-6	IEC 60034-6
Dimensioni e potenze nominali per macchine elettriche rotanti <i>Dimensions and output ratings for rotating electrical machines</i> Auslegung der Nennleistung von umlaufenden elektrischen Maschinen <i>Dimensions, puissances nominales pour machines électriques tournantes</i>	EN 50347	IEC 60072
Classificazione dei gradi di protezione delle macchine elettriche rotanti <i>Classification of degree of protection provided by enclosures for rotating machines</i> Klassifizierung der Schutzart von umlaufenden elektrischen Maschinen <i>Classification des degrés de protection des machines électriques tournantes</i>	CEI EN 60034-5	IEC 60034-5
Limiti di rumorosità <i>Noise limits</i> Geräuschgrenzwerte <i>Limites de bruit</i>	CEI EN 60034-9	IEC 60034-9
Sigle di designazione delle forme costruttive e dei tipi di installazione <i>Classification of type of construction and mounting arrangements</i> Abkürzungen zur Kennzeichnung der Bauform und der Einbaulagen <i>Sigles de dénomination des formes de construction et des types d'installation</i>	CEI EN 60034-7	IEC 60034-7
Tensione nominale per i sistemi di distribuzione pubblica dell'energia elettrica a bassa tensione <i>Rated voltage for low voltage mains power</i> Nennspannung für öffentliche NS-Stromverteilungssysteme <i>Tension nominale pour les systèmes de distribution publique de l'énergie électrique en basse tension</i>	CEI 8-6	IEC 60038
Grado di vibrazione delle macchine elettriche <i>Vibration level of electric machines</i> Schwingstärke bei elektrischen Maschinen <i>Degré de vibration des machines électriques</i>	CEI EN 60034-14	IEC 60034-14

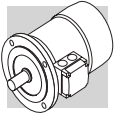

I motori corrispondono inoltre alle Norme straniere elencate qui di seguito:

Motors are also in compliance with the national Standards listed below:

Die Motoren entsprechen darüber hinaus den nachstehend aufgelisteten ausländischen Normen:

Les moteurs correspondent aussi aux Normes étrangères suivantes :

(02)

DIN VDE 0530	Germania	<i>Germany</i>	Deutschland	<i>Allemagne</i>
BS5000 / BS4999	Gran Bretagna	<i>Great Britain</i>	Großbritannien	<i>Grande Bretagne</i>
AS 1359	Australia	<i>Australia</i>	Australien	<i>Australie</i>
NBNC 51-101	Belgio	<i>Belgium</i>	Belgien	<i>Belgique</i>
NEK - IEC 60034-1	Norvegia	<i>Norway</i>	Norwegen	<i>Norvège</i>
NF C 51	Francia	<i>France</i>	Frankreich	<i>France</i>
OEVE M 10	Austria	<i>Austria</i>	Österreich	<i>Autriche</i>
SEV 3009	Svizzera	<i>Switzerland</i>	Schweiz	<i>Suisse</i>
NEN 3173	Paesi Bassi	<i>Netherlands</i>	Niederlande	<i>Pays Bas</i>
SS 426 01 01	Svezia	<i>Sweden</i>	Schweden	<i>Suède</i>

Direttive CEE 73/23 (LVD) e CEE 89/336 (EMC)

Directives 73/23/ EEC (LVD) and 89/336/ EEC (EMC)

Richtlinien EWG 73/23 (LVD) und EWG 89/336 (EMC)

Directives CEE 73/23 (LVD) e CEE 89/336 (EMC)

I motori della serie BN sono conformi ai requisiti delle Direttive CEE 73/23 (Direttiva Bassa Tensione) e CEE 89/336 (Direttiva Compatibilità Elettromagnetica), e riportano in targa la marcatura CE. Per quanto riguarda la Direttiva EMC, la costruzione è in accordo alle Norme CEI EN 60034-1 sez. 12, EN 50081, EN 50082.

BN motors meet the requirements of Directives 73/23/EEC (Low Voltage Directive) and 89/336/EEC (Electromagnetic Compatibility Directive) and their name plates bear the CE mark. As for the EMC Directive, construction is in accordance with standards CEI EN 60034-1 Sect. 12, EN 50081, EN 50082.

Die Motoren der Serie BN entsprechen den Anforderungen der Richtlinien EWG 73/23 (Richtlinie - Niederspannung) und CEE 89/336 (Richtlinie - elektromagnetische Kompatibilität) und sind mit dem CE-Zeichen ausgestattet. Im Hinblick auf die Richtlinie EMC entspricht die Konstruktion den Normen CEI EN 60034-1, Abschn. 12, EN 50081, EN 50082.

Les moteurs de la série BN sont conformes aux conditions requises par les Directives CEE 73/23 (Directive Basse Tension) et CEE 89/336 (Directive Compatibilité Electromagnétique), et le marquage CE est indiqué sur la plaque signalétique. En ce qui concerne la Directive EMC, la fabrication répond aux Normes CEI EN 60034-1 Sect. 12, EN 50081, EN 50082.

I motori con freno FD, se corredati dell'opportuno filtro capacitativo in ingresso al raddrizzatore (variante **CF**), rientrano nei limiti di emissione previsti dalla Norma EN 50081- "Compatibilità elettromagnetica - Norma Generica sull'emissione - Parte 1: Ambienti residenziali, commerciali e dell'industria leggera".

*Motors with FD brakes, when fitted with the suitable capacitive filter at rectifier input (option **CF**), meet the emission limits required by Standard EN 50081-1 "Electromagnetic compatibility - Generic Emission Standard - Part 1: Residential, commercial and light industrial environment".*

Die Motoren mit dem Bremstyp FD fallen, falls mit dem entsprechenden kapazitiven Filter am Eingang des Gleichrichters ausgestattet (Option **CF**), unter die Emissionsgrenzwerte, die von der Norm EN 50081-1 "Elektromagnetische Kompatibilität - Allgemeine Norm für Emissionen - Teil 1: Wohngebiete, Handels- und Leichtinduszriezonen" vorgesehen werden".

*Les moteurs avec frein FD, s'ils sont équipés du frein capacitif approprié en entrée du redresseur (option **CF**), rentrent dans les limites d'émission prévues par la Norme EN 50081-1 "Compatibilité électromagnétique - Norme Générique sur l'émission - Partie 1: Milieux résidentiels, commerciaux et de l'industrie légère".*

I motori soddisfano inoltre le prescrizioni della Norma CEI EN 60204-1 "Equipaggiamento elettrico delle macchine".

Motors also meet the requirements of standard CEI EN 60204-1 "Electrical equipment of machines".

Die Motoren entsprechen darüber hinaus den von der Norm CEI EN 60204-1 "Elektrische Maschinenausstattung" gegebenen Vorschriften.

Les moteurs répondent aussi aux prescriptions de la Norme CEI EN 60204-1 "Equipement électrique des machines".

È responsabilità del costruttore o dell'assemblatore dell'apparecchiatura che incorpora i motori come componenti garantire la sicurezza e la conformità alle direttive del prodotto finale.

The responsibility for final product safety and compliance with applicable directives rests with the manufacturer or the assembler who incorporate the motors as component parts.

Es liegt in der Verantwortung des Herstellers oder des Monteurs der Anlage, in der die Motoren als Komponenten montiert werden, die Sicherheit und die Übereinstimmung mit den Richtlinien des Endprodukts zu gewährleisten.

Le fabricant ou le monteur de la machine qui comprend les moteurs comme composant est responsable et doit se charger de garantir la sécurité et la conformité aux directives du produit final.

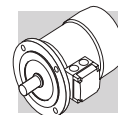

Rendimento – Accordo CEMEP

Con l'obiettivo di ridurre significativamente il consumo europeo di energia elettrica mediante la sensibilizzazione degli utenti all'uso di motori maggiormente efficienti, la Commissione Europea per l'Energia e il CEMEP hanno concordato le condizioni ricorrenti per la classificazione dei motori elettrici in classi di rendimento denominate, in senso decrescente, **eff1**, **eff2** ed **eff3**.

Oggetto di questo accordo sono solamente i motori trifase standard in c.a. a 2 e 4 poli, costruzione chiusa con rotore a gabbia di scoiattolo, ventilazione esterna e potenza all'albero compresa fra 1,1 e 90 kW, alimentazione a 400V - 50 Hz in servizio continuo S1.

È facoltà dei costruttori di motori elettrici decidere di classificare volontariamente i propri prodotti in una delle tre classi di rendimento sopra citate. In questo caso essi devono apporre sulla targa il marchio relativo alla classe di rendimento applicabile ed inserire, fra i dati tecnici, i valori di rendimento a pieno carico ed a $\frac{3}{4}$ del carico nominale. I motori Bonfiglioli ricompresi nell'oggetto di questo accordo sono conformi alla classe di rendimento **eff2** e sono pertanto chiaramente identificati in targa tramite il logo sotto riportato:

Efficiency – the CEMEP agreement

*CEMEP, the European Committee of Manufacturers of Electrical Machines and Power Electronics hopes to reduce electrical energy consumption in Europe by informing users of the efficiency of electrical motors. As a contribution in this direction, CEMEP has recently published an agreement stating the specifications for electric motor energy efficiency classes **eff1**, **eff2** and **eff3** (listed in order of decreasing efficiency).*

The CEMEP agreement covers only standard, 2 and 4 pole, three phase, AC motors, of closed rotor and squirrel cage construction, with external ventilation and rated power at the output shaft of 1.1 to 90 kW, for use with a 400V - 50 Hz power supply under S1 continuous duty conditions.

It is left up to individual electric motor manufacturers to classify their products in one of the three above classes. If they decide to do so, they must apply the relevant efficiency mark to the motor and include, together with all the other relevant technical specifications, the measured efficiency figures for full rated load and $\frac{3}{4}$ rated load.

*Under the terms of this agreement, Bonfiglioli's electric motors conform to efficiency class **eff2** and are clearly identified as such by the following mark on the data plate:*

Wirkungsgrad - die CEMEP Vereinbarung

CEMEP, der europäische Herstellerverband von elektrischen Maschinen und Leistungs-Elektronik hofft, den elektrischen Energieverbrauch in Europa, durch Informationen über die Wirkungsgrade von elektrischen Motoren an die Benutzer, zu reduzieren.

Als Beitrag in dieser Richtung, hat die CEMEP vor kurzem eine Vereinbarung veröffentlicht, die die Energie-Effizienz-Klassen **eff1**, **eff2** und **eff3** für Elektromotoren spezifiziert. (Aufgelistet nach abnehmendem Wirkungsgrad).

Die CEMEP Vereinbarung beinhaltet nur 2 und 4 polige Drehstrommotoren mit geschlossenem Rotor als Kurzschlussläufer, integriertem Lüfter, Nennleistungen an der Abtriebswelle von 1.1 - 90 kW, mit einer Energieversorgung von 400V - 50Hz und der Betriebsart S1 (Dauerbetrieb).

Es bleibt den einzelnen Elektromotoren Herstellern überlassen, ihre Produkte nach einer der drei oben benannten Effizienz-Klassen zu klassifizieren. Wenn sie sich dazu entscheiden, müssen sie die relevante Markierung auf dem Motor anbringen und zusammen mit all den anderen relevanten technischen Einzelheiten, die gemessenen Wirkungsgradangaben bei Voll- und Dreiviertellast ausweisen.

Unter den Bedingungen dieser Vereinbarung entsprechen die elektrischen Motoren von Bonfiglioli der Effizienz-Klasse **eff2** und werden als solche durch die folgende Markierung auf dem Typenschild deutlich gekennzeichnet:

Rendement – L'accord CEMEP

*La Commission Européenne sur l'Energie et le CEMEP (European Committee of Manufacturers of Electrical Machines and Power Electronics), espère réduire de façon sensible la consommation européenne d'énergie électrique à travers l'information sur l'efficience des moteurs électriques. Pour ce faire, ils ont fixés une classification des moteurs électriques en « classes de rendement » appelée, en sens décroissant d'efficience : **eff1**, **eff2** et **eff3**.*

Font partie de cet accord seulement les moteurs triphasés standard en c.a. à 2 et 4 pôles, de type fermé et rotor à cage, ventilation extérieure et puissance à l'arbre comprise entre 1,1 et 90 KW, alimentation à 400V- 50 Hz en service continue S1.

C'est au choix de chaque constructeur de moteurs électriques de décider de classer ces produits dans une des trois classes de rendement ci-dessus. Dans ce cas, le constructeur doit faire apparaître le logo de la classe de rendement sur la plaque marque et introduire, dans les caractéristiques techniques, les valeurs de rendement à pleine charge et à $\frac{3}{4}$ de la charge nominale.

*Le moteurs Bonfiglioli concernées dans cet accord, sont conformes à la classe de rendement **eff2** et de conséquence ils présentent, sur la plaque marque, le logo suivant :*



M3 - TOLLERANZE

Secondo le Norme CEI EN 60034-1 sono ammesse le tolleranze qui indicate per le grandezze garantite:

M3 - TOLERANCES

Allowed tolerances for guaranteed parameters in accordance with standards CEI EN 60034-1 are indicated in the table below:

M3 - TOLERANZEN

Den Normen CEI EN 60034-1 entsprechend sind für die angegebenen Werte folgende Toleranzen zulässig:

M3 - TOLERANCES

Selon les Normes CEI EN 60034-1 les tolérances indiquées ci-dessous sont admises pour les tailles garanties :

-0.15 (1 - η) P \leq 50 kW	Rendimento	Efficiency	Wirkungsgrad	Rendement
$-(1 - \cos\phi) / 6$ min 0.02 max 0.07	Fattore di potenza	Power factor	Leistungsfaktor	Facteur de puissance
$\pm 20\%$ (*)	Scorrimento	Slip	Schlupf	Glissement
+ 20%	Corrente a rotore bloccato	Locked rotor current	Strom bei blockiertem Läufer	Courant à rotor bloqué
-15% + 25%	Coppia a rotore bloccato	Locked rotor torque	Drehmoment bei blockiertem Läufer	Couple à rotor bloqué
-10%	Coppia max	Max. torque	Max. Drehmoment	Couple max

(*) $\pm 30\%$ per motori con $P_n < 1$ kW

(*) $\pm 30\%$ for motors with $P_n < 1$ kW

(*) $\pm 30\%$ für Motoren mit $P_n < 1$ kW

(*) $\pm 30\%$ pour moteurs avec $P_n < 1$ kW

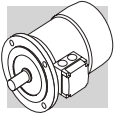

M3.1 - TOLLERANZE GEOMETRICHE

L'estremità d'albero, la linguetta e la flangia hanno dimensioni e tolleranze secondo EN 50347, IEC 60072-1, CEI-UNEL 13501. Le estremità d'albero sono previste di foro filettato in testa secondo UNI 9321, DIN 332. I motori sono sempre forniti con linguetta inserita nella sede. La tabella seguente riporta le tolleranze previste per le diverse parti:

M3.1 - GEOMETRIC TOLERANCES

Dimensions and tolerances of shaft end, key and flange are in accordance with EN 50347, IEC 60072-1, CEI-UNEL 13501. Shaft ends feature an axial threaded hole in accordance with UNI 9321, DIN 332 and a key inserted in the suitable keyway. The following table reports the tolerances for the different parts:

M3.1 - GEOMETRISCHE TOLERANZEN

Die Wellenenden, der Federkeil und der Flansch entsprechen im Hinblick auf ihre Maße und Toleranzen den Normen EN 50347, IEC 60072-1 und CEI-UNEL 13501. Die Wellenenden sind an ihrer Stirnseite mit einer Gewindebohrung gemäß UNI 9321, DIN 332 versehen und werden mit einem in seinen Sitz eingefügten Federkeil geliefert. In der nachstehenden Tabelle werden für die verschiedenen Teile die entsprechenden Toleranzen angegeben:

M3.1 - TOLERANCES GEOMETRIQUES

L'extrémité de l'arbre, la clavette et la bride présentent des dimensions et tolérances selon EN 50347, IEC 60072-1, CEI-UNEL 13501. Les extrémités d'arbre sont dotées d'orifice fileté en tête, selon UNI 9321, DIN 332 ainsi que la clavette introduite dans le logement. Le tableau suivant indique les tolérances prévues pour les différentes pièces :

(03)

Componente / Component Komponente / Composant	Dimensioni / Dimensions Abmessungen / Dimensions		Tolleranza / Tolerance Tolérance / Tolérance
Estremità albero / Shaft end Wellenende / Extrémité arbre	D - DA	∅ 11 - 28	j6
		∅ 38 - 48	k6
		∅ ≥ 55	m6
Linguetta / Key Federkeil / Clavette	F - FA		h9
Flangia / Flange Flansch / Bride	N	∅ < 250	j6
		∅ ≥ 250	h6

M3.2 - RUMOROSITÀ

I valori di rumorosità, rilevati secondo il metodo indicato dalle Norme ISO 1680, sono contenuti entro i livelli massimi previsti dalle Norme CEI EN 60034-9.

M3.2 - NOISE LEVEL

Noise levels measured using the method specified by standard ISO 1680 are within the maximum limits required by standards CEI EN 60034-9.

M3.2 - GERÄUSCHPEGEL

Der Geräuschpegel wurde entsprechend der in der Norm ISO 1680 angegebenen Methode gemessen und liegt innerhalb der max. Werte, die von der Norm CEI EN 60034-9 vorgeschrieben werden.

M3.2 - NIVEAU DE BRUIT

Les valeurs du niveau de bruit, mesurées selon la méthode indiquées par les Normes ISO 1680 sont contenues dans les limites maximums prévues par les Normes CEI EN 60034-9.

M4 - SENSO DI ROTAZIONE

È possibile il funzionamento dei motori in entrambi i versi di rotazione. Con collegamento dei morsetti U1, V1, W1 alle fasi di linea L1, L2, L3 si ottiene la rotazione oraria, osservando l'albero dal lato accoppiamento. La marcia antioraria si ottiene scambiando fra loro due fasi.

M4 - DIRECTION OF ROTATION

Motors may operate in both directions of rotation. When the terminals U1, V1, W1 are connected to the line phases L1, L2, L3, the motor will run in a clockwise direction as viewed from the coupling end. Counter clockwise rotation is obtained by swapping two phases.

M4 - DREHRICHTUNG

Die Motoren können in beiden Drehrichtungen betrieben werden. Schließt man die Klemmen U1, V1, W1 an die Phasen L1, L2, L3 an, dreht sich der Motor, mit Sicht auf die Motorwelle betrachtet, im Uhrzeigersinn. Eine Drehrichtungsumkehr gegen den Uhrzeigersinn erhält man durch das Wechseln von zwei Phasen.

M4 - SENS DE ROTATION

Le fonctionnement des moteurs dans les deux sens de rotation est possible. Avec raccordement des bornes U1, V1, W1 aux phases de ligne L1, L2, L3 on obtient la rotation dans le sens des aiguilles d'une montre, en observant l'arbre côté accouplement. Invertir deux des phases pour obtenir la rotation dans le sens inverse des aiguilles d'une montre.

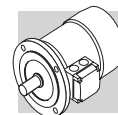

M5 - CUSCINETTI

I cuscinetti previsti sono del tipo radiale a sfere, precaricati assialmente, e dotati di carica di grasso per lubrificazione permanente.

La durata nominale a fatica L_{10h} in assenza di carichi esterni applicati all'albero e montaggio orizzontale è superiore a 40.000 ore. I tipi utilizzati sono indicati nella tabella seguente:

M5 - BEARINGS

Axially pre-loaded radial ball bearings, lubricated for life with the grease.

Nominal fatigue life $L_{10h} \sim 40,000$ hours assuming no overhung load on the shaft, and mounting position horizontal.

The types of bearings in use are listed in the table below:

M5 - LAGER

Bei den verwendeten Lagern handelt es sich um axial vorge-spannte Radialkugellager mit einer für die Dauerschmierung ausgelegten Fettfüllung.

Der Nennwert der Ermüdungsdauer L_{10h} ohne auf die Welle einwirkenden Kräften und bei horizontaler Montage liegt bei über 40.000 Stunden:

M5 - ROULEMENTS

Les roulements prévus sont du type radial à billes, préchargés du point de vue axial et remplis de graisse pour une lubrification permanente.

La durée nominale à la fatigue L_{10h} , en l'absence de charges externes appliquées à l'arbre et avec un montage horizontal, est supérieure à 40.000 heures :

(04)

	DE	NDE	
	Tutti i motori / All motors Alle Motoren / Tous les moteurs		BN_FD; BN_FA
BN 56	6201 2Z C3	6201 2Z C3	—
BN 63	6201 2Z C3	6201 2Z C3	6201 2RS C3
BN 71	6202 2Z C3	6202 2Z C3	6202 2RS C3
BN 80	6204 2Z C3	6204 2Z C3	6204 2RS C3
BN 90	6205 2Z C3	6205 2Z C3	6205 2RS C3
BN 100	6206 2Z C3	6206 2Z C3	6206 2RS C3
BN 112	6306 2Z C3	6306 2Z C3	6306 2RS C3
BN 132	6308 2Z C3	6308 2Z C3	6308 2RS C3
BN 160MR	6309 2Z C3	6308 2Z C3	6308 2RS C3
BN 160M/L	6309 2Z C3	6309 2Z C3	6309 2RS C3
BN 180M	6310 2Z C3	6309 2Z C3	6309 2RS C3
BN 180L	6310 2Z C3	6310 2Z C3	6310 2RS C3
BN 200L	6312 2Z C3	6310 2Z C3	6310 2RS C3

DE = lato comando
NDE = lato opposto comando

DE = drive end
NDE = non drive end

DE = Wellenseite
NDE = Lüfterseite

DE = sortie arbre
NDE = côté ventilateur

M6 - OPERATIVITÀ STANDARD

M6.1 - TENSIONE

I motori a singola polarità sono previsti, nell'esecuzione standard, per tensione nominale 230/400V Δ/Y (o 400/690 V Δ/Y per le grandezze da BN160 e BN 200) 50 Hz con tolleranza $\pm 10\%$ (Eurotensione).

M6 - STANDARD OPERATION

M6.1 - VOLTAGE

Standard single-speed motors are designed to operate from a rated voltage 230/400V Δ/Y (or 400/690V Δ/Y for frame sizes BN 160 through BN 200) 50 Hz, with $\pm 10\%$ tolerance (Euro-voltage).

M6 - STANDARDVERSORGUNG

M6.1 - SPANNUNG

Die einpoligen Motoren sind in der Standardausführung für eine Nennspannung von 230/400V Δ/Y (oder 400/690V Δ/Y für die Bau-größen von BN 160 bis BN 200) 50 Hz, mit einer Toleranz $\pm 10\%$ (Euro-Spannung) ausgelegt. Die-

M6 - CONDITIONS OPERATIVES

M6.1 - TENSION

Les moteurs à simple polarité sont prévus, dans l'exécution standard, pour une tension nominale de 230/400V Δ/Y (ou 400/690V Δ/Y pour les tailles de BN 160 à BN 200) 50 Hz, avec une tolérance de $\pm 10\%$ (Euroten-

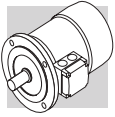

I motori sono idonei per funzionamento sulla rete di distribuzione europea con tensione in accordo alla pubblicazione IEC 60038.

In targa sono indicati oltre alla tensione nominale, i campi di funzionamento consentiti, p.e. 220-240V Δ /380-415V Y, 50 Hz. In accordo alla Norma CEI EN 60034-1, i motori possono funzionare alle tensioni sopra indicate con tolleranza del $\pm 5\%$ (Zona A).

Per funzionamento ai limiti della tolleranza la temperatura può superare di 10 K il limite previsto dalla classe di isolamento adottata.

Motors are suitable for operation with European power mains with voltage in accordance with publication IEC 60038.

Besides rated voltage, the name plate reports allowed operating ranges, e.g. 220-240V Δ /380-415V Y, 50Hz. In accordance with standard CEI EN 60034-1, motors may operate at the above mentioned voltages with $\pm 5\%$ tolerance (Zone A).

In operation at tolerance limits, temperature may exceed the temperature limit required by the adopted insulation class by 10 K.

se Motoren eignen sich für einen Betrieb im Europäischen Versorgungsnetz mit einer Spannung, die den in der Veröffentlichung IEC 60038 angegebenen Werten entspricht. Auf dem Typenschild werden über die Nennspannung hinaus, auch die zulässigen Toleranzbereiche angegeben, z.B. 220-240V Δ /380-415V Y, 50 Hz. In Übereinstimmung mit der Norm CEI EN 60034-1 können die Motoren unter den o.g. Spannungswerten mit einer Toleranz von $\pm 5\%$ (Bereich A) arbeiten. Bei einem Betrieb an den Toleranzgrenzen kann die Temperatur die vorgesehene Isolationsklasse um 10 K überschreiten.

Les moteurs sont adaptés pour fonctionner sur le réseau de distribution européen avec une tension correspondant aux indications de la norme CEI 60038.

Sur la plaque signalétique sont indiquées, outre la tension nominale, les plages de fonctionnement autorisées, par ex. 220-240V Δ /380-415V Y, 50 Hz. En accord avec la norme CEI EN 60034-1, les moteurs peuvent fonctionner aux tensions susmentionnées avec une tolérance de $\pm 5\%$ (Zone A). Pour un fonctionnement aux limites de la tolérance, la température peut dépasser de 10 K la limite prévue pour la classe d'isolation adoptée.

(05)

	$V_{mot} \pm 10\%$ 3~	Esecuzione Configuration Ausführung Execution
BN 56 ... BN 132	230/400 V Δ /Y 460 V Y	50 Hz 60 Hz Standard
BN 160 ... BN 200	400/690 V Δ /Y 460 V Δ	50 Hz 60 Hz Standard
BN 100 ... BN 132	400/690 V Δ /Y 460 V Δ	50 Hz 60 Hz A richiesta, senza sovrapprezzo At request, carries no extra charge Auf Anfrage, ohne Aufpreis Sur demande, sans majoration de prix

I motori a doppia polarità sono previsti per alimentazione standard 400V / 50 Hz; tolleranze applicabili secondo CEI EN 60034-1.

Nella tabella (06) sono indicati i collegamenti previsti in funzione della polarità:

Switch-pole motors are designed to operate from 400V - 50 Hz standard power supply. Applicable tolerances are in accordance with standard CEI EN 60034-1. The table (06) reports the required connections depending on the number of poles:

Die polumschaltbaren Motoren sind für eine Standardversorgung von 400V – 50 Hz ausgelegt; Toleranzen gelten gemäß CEI EN 60034-1. In der Tabelle (06) werden in Abhängigkeit von den jeweiligen Polzahlen die Wicklungsanschlüsse angegeben:

Les moteurs à double polarité sont prévus pour une alimentation standard 400V – 50 Hz ; tolérances applicables selon la norme CEI EN 60034-1. Les branchements prévus en fonction de la polarité sont indiqués sur le tableau (06) :

(06)

	Poli Number of poles Polzahl Nombre de poles	Collegamento avvolgimento Winding connection Wicklungsanschluß Connexion du bobinage
BN 63 ... BN 200	2,4,6,8	Δ /Y
	2/4, 4/8	Δ / YY (Dahlander)
	2/6, 2/8, 2/12, 4/6	Y / Y (due avvolgimenti Two windings Zwei wicklungen Deux bobinage)

M6.2 - FREQUENZA

I motori della serie BN sono previsti per essere normalmente utilizzati su reti a 50 Hz o 60 Hz.

M6.2 - FREQUENCY

The motors of the BN series may operate under 50 or 60 Hz supply.

M6.2 - FREQUENZ

Die Motoren der Serie BN können mit 50 Hz oder 60 Hz betrieben werden.

M6.2 - FREQUENCE

Les moteurs de la série BN peuvent être normalement utilisés sur des réseaux en 50 Hz ou 60 Hz.

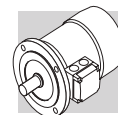

M6.3 - TEMPERATURA AMBIENTE

Le tabelle dati tecnici del catalogo riportano le caratteristiche funzionali a 50Hz, per le condizioni di installazione previste dalle Norme CEI EN 60034-1 (temperatura compresa tra -15 °C e +40 °C ed altitudine ≤ 1000 m s.l.m.).
I motori possono essere impiegati con temperature comprese tra 40 °C e 60 °C applicando i declassamenti di potenza indicati nella tabella (07):

M6.3 - AMBIENT TEMPERATURE

*Catalog rating charts report operating characteristics at 50 Hz, under installation conditions as specified by standards CEI EN 60034-1 (temperature between -15 °C and + 40 °C and altitude above sea level ≤ 1000 m).
Motors may be used at ambient temperatures between 40°C and 60°C as long as the derating factors listed in the table (07) are applied:*

M6.3 - UMGEBUNGSTEMPERATUR

Die im Katalog enthaltenen Tabellen geben die Betriebsdaten bei 50 Hz für die Einbaubedingungen gemäß den Normen CEI EN 60034-1 (Temperatur zwischen -15 °C und + 40 °C und Höhe ≤ 1000 m ü. M.) an.
Die Motoren können auch bei Temperaturen zwischen 40°C und 60°C eingesetzt werden, in diesem Fall müssen jedoch die in der Tabelle (07) angegebenen Leistungsreduzierungen beachtet werden:

M6.3 - TEMPERATURE AMBIANTE

Les tableaux des caractéristiques techniques du catalogue indiquent les caractéristiques de fonctionnement à 50 Hz, pour les conditions d'installation prévues par les normes CEI EN 60034-1 (température comprise entre -15 °C et + 40 °C à une altitude de ≤ 1000 m). Les moteurs peuvent être utilisés à des températures comprises entre 40°C et 60°C en appliquant les déclassements de puissance indiqués dans le tableau (07) :

(07)

Temperatura ambiente / Ambient temperature Umgebungstemperatur / Température ambiante	[°C]	40°	45°	50°	55°	60°
Potenza ammissibile in % della potenza nominale Permitted power as a % of rated power Zulässige Leistung in % der Nennleistung Puissance admissible en % de la puissance nominale		100%	95%	90%	85%	80%

Quando è richiesto un declassamento del motore superiore al 15%, contattare il ns. Servizio Tecnico.

When the applicable derating factor for the motor exceeds 15%, please contact our Technical Service Dept.

Ist eine Rückstufung des Motors von mehr als 15% erforderlich, setzen sie sich bitte mit unserem Technischen Kundendienst in Verbindung.

En cas de nécessité d'un déclassement du moteur supérieur à 15%, contacter notre Service Technique.

M7 - FUNZIONAMENTO A 60 Hz

I motori della serie BN possono essere normalmente utilizzati anche su reti a 60 Hz.
Ad esclusione dei motori autofrenanti in c.c., tipo BN_FD, nella targa dei motori, oltre alle tensioni a 50 Hz, sono riportati i valori corrispondenti al funzionamento a 460 V - 60Hz, ed il relativo campo di tensione 440-480V.

M7 - 60 Hz OPERATION

BN motors may also operate with 60 Hz power mains. Except for DC brake motors type BN_FD, motor name plate reports 50 Hz voltage ratings, as well as the values for operation at 460 V - 60Hz and the corresponding voltage range 440-480V.

M7 - BETRIEB BEI A 60 Hz

Die Motoren der Serie BN können normalerweise auch in Stromnetzen mit 60 Hz Frequenz eingesetzt werden.
Mit Ausnahme der Bremsmotoren mit Gleichstromes vom Typ BN_FD, werden auf dem Typenschild der Motoren über die Angabe der Spannungen bei 50 Hz auch die Werte angegeben, die einem Betrieb bei 460 V - 60Hz entsprechen. Darüber hinaus kann man diesem Schild den entsprechenden Spannungsbereich 440-480V entnehmen.

M7 - FONCTIONNEMENT A 60 Hz

Les moteurs de la série BN peuvent aussi être normalement utilisés sur des réseaux à 60 Hz. A l'exception des moteurs frein en c.c., type BN_FD, sur la plaque signalétique des moteurs, outre la tension à 50 Hz, sont indiqués les valeurs correspondant au fonctionnement à 460 V - 60Hz ainsi que la plage de tension relative 440-480V.

In corrispondenza dell'alimentazione 460V-60 Hz la targa del motore riporta valori di potenza aumentata di circa il 20% (non applicabile ai motori autofrenanti con freno in c.c., tipo BN_FD).

For 460V-60 Hz power supply, the power ratings reported in the motor name plate are about 20% higher (does not apply to DC brake motors type BN_FD). Name plate rated power for op-

Bei einer Spannungsversorgung mit 460V-60 Hz werden auf dem Typenschild etwa 20% höhere Leistungswerte angegeben (gilt nicht für die Bremsmotoren mit Gleichstrombremse

En face de l'alimentation 460V-60 Hz la plaque signalétique du moteur indiquent les valeurs de puissance majorée d'environ 20% (non applicable aux moteurs frein avec frein en

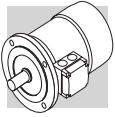

La potenza nominale di targa, a 60 Hz, è quella riportata nella tabella (08) seguente:

eration with 60 Hz power mains is as reported in the table below (08):

vom Typ BN_FD). Der nachstehenden Tabelle (08) können Sie die auf dem Typenschild angegebene Nennleistung bei 60 Hz entnehmen:

c.c., type BN_FD).

La puissance nominale indiquée sur la plaque, à 60 Hz, est celle figurant dans le tableau (08) suivant :

(08)

	Pn [kW]			
	2p	4p	6p	8p
56A	—	0.07	—	—
56B	—	0.10	—	—
63A	0.21	0.14	0.10	—
63B	0.30	0.21	0.14	—
63C	0.45	0.30	—	—
71A	0.45	0.30	0.21	0.10
71B	0.65	0.45	0.30	0.14
71C	0.90	0.65	0.45	—
80A	0.90	0.65	0.45	0.21
80B	1.30	0.90	0.65	0.30
80C	1.80	1.3	0.90	—
90S	—	1.3	0.90	0.45
90SA	1.8	—	—	—
90SB	2.2	—	—	—
90L	2.5	—	1.3	0.65
90LA	—	1.8	—	—
90LB	—	2.2	—	—
100L	3.5	—	—	—
100LA	—	2.5	1.8	0.85
100LB	4.7	3.5	2.2	1.3
112M	4.7	4.7	2.5	1.8
132S	—	6.5	3.5	2.5
132SA	6.5	—	—	—
132SB	8.7	—	—	—
132M	11	—	—	3.5
132MA	—	8.7	4.6	—
132MB	—	11	6.5	—
160MR	12.5	12.5	—	—
160MB	17.5	—	—	—
160M	—	—	8.6	—
160L	21.5	17.5	12.6	—
180M	24.5	21.5	—	—
180L	—	25.3	17.5	—
200L	34	34	22	—

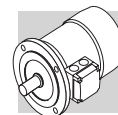

Per i motori a doppia polarità con frequenza di alimentazione 60Hz l'incremento di potenza previsto, rispetto a quanto riportato nelle tabelle dati tecnici a 50 Hz, è circa del 15%.

I motori ad una velocità con avvolgimento standard, se utilizzati su reti a 60 Hz e tensioni come riportato in tabella (09), presentano variazioni delle grandezze principali come nel seguito descritto:

For switch-pole motors operating with 60 Hz input frequency, the power increase factor over 50 Hz ratings is in the order of 15%.

Key parameter variations for single-pole motors with standard winding operating with 60 Hz power mains at the voltage ratings reported in the table (09) are reported below (variations expressed as percentages):

Für die polumschaltbaren Motoren mit einer Spannungsversorgung von 60 Hz beträgt die Leistungserhöhung im Vergleich zu den Angaben in der Tabelle der sich auf 50 Hz beziehenden technischen Daten ungefähr 15%.

Für die einpoligen Motoren mit Standardwicklung die in Versorgungsnetzen mit 60 Hz und mit Spannungen gemäß Tabelle (09) eingesetzt werden, gelten die folgenden Werte:

Pour les moteurs à double polarité avec fréquence d'alimentation 60 Hz l'augmentation de puissance prévue, par rapport aux indications des tableaux des caractéristiques techniques à 50 Hz, est d'environ 15%.

Les moteurs à une vitesse avec bobinage standard, lorsqu'ils sont utilisés sur des réseaux à 60 Hz et des tensions comme indiqué dans le tableau (09), présentent des variations des valeurs principales en pourcentage comme indiqué ci-dessous :

(09)

50 Hz	60 Hz			
V	V	Pn	Mn, Ma/Mn	n [min ⁻¹]
230/400 Δ /Y	220 - 240 Δ 380 - 415 Y	1	0.83	1.2
400/690 V Δ /Y	380 - 415 Δ			
230/400 V Δ /Y	265 - 280 Δ 440 - 480 Y	1.15	1	1.2
400/690 V Δ /Y	440 - 480 Δ			
230/400 V Δ /Y	265 - 280 Δ 440 - 480 Y	1.15	1	1.2
400/690 V Δ /Y	440 - 480 Δ			

I freni, se presenti, dovranno sempre essere alimentati come riportato in targa.

Brakes, if fitted, must always be supplied as specified on the name plate.

Die Bremsen, falls vorhanden, müssen immer wie gezeichnet auf dem Typenschild versorgt werden.

Si présents, les freins doivent toujours être alimentés indiquée sur la plaque signalétique.

PN

L'opzione consente di avere sulla targa del motore il valore di potenza normalizzata a 50 Hz, anche quando è specificata l'alimentazione a 60 Hz.

With this option, motor name plate includes 50 Hz normalized power information even when motor is designated for operation with 60 Hz power mains.

Diese Option ermöglicht es auf dem Typenschild des Motors den Wert der auf 50 Hz genormten Leistung angeben zu können, auch wenn eine Spannungsversorgung bei 60 Hz erfolgt.

L'option permet d'avoir sur la plaque signalétique du moteur la valeur de puissance normalisée à 50 Hz, même lorsque l'alimentation à 60 Hz est spécifiée.

Per alimentazioni a 60 Hz con le tensioni 230/460V e 575V l'opzione PN viene applicata di default.

For 60 Hz supplies along with voltages 230/460V and 575V the PN option is applied by default.

Die Option PN ist immer dabei mit 60 Hz und Spannungsversorgung 230/460V und 575V 60 Hz.

Pour alimentations à 60 Hz avec tensions 230/460V et 575V l'option PN est appliqué de default.

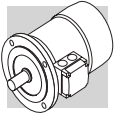

**M7.1 - MOTORI PER USA
E CANADA**

**M7.1 - MOTORS FOR USA
AND CANADA**

**M7.1 - MOTOREN FÜR
DIE USA UND KANADA**

**M7.1 - MOTEURS POUR
ETATS-UNIS
ET CANADA**

CUS

I motori da BN 56 a BN 200 sono disponibili in esecuzione NEMA Design C (per le caratteristiche elettriche), certificata in conformità alle norme CSA (Canadian Standard) C22.2 N°100 e UL (Underwriters Laboratory) UL 1004 con targhetta riportante entrambi i marchi sotto illustrati:

BN motor's sizes 56 through 200, are available in NEMA Design C configuration (concerning electrical characteristics), certified to CSA (Canadian Standard) C22.2 No. 100 and UL (Underwriters Laboratory) UL 1004. By specifying the option CUS the name plate is marked with both symbols shown here below:

Die Motoren BN 56 bis BN 200 sind in der Ausführung NEMA, Design C erhältlich (hinsichtlich der elektrischen Eigenschaften). Zertifiziert nach den Normen CSA (Canadian Standard) C22.2 Nr. 100 und UL (Underwriters Laboratory) UL 1004. Durch Spezifizieren der Option CUS wird das Typenschild mit den nachstehend aufgeführten Symbolen gekennzeichnet:

Les moteurs BN 56...BN 200 sont disponibles en exécution NEMA Design C (pour les caractéristiques électriques), certifiée conforme aux normes CSA (Canadian Standard) C22.2 N°100 et UL (Underwriters Laboratory) UL 1004 avec une plaque signalétique indiquant chacun des symboles ci-dessous :



(tensione ≤ 600V).

(voltage ≤ 600V)

Zeichen (Spannung ≤ 600V) versehen.

(tension ≤ 600V).

Le tensioni delle reti di distribuzione americane e le corrispondenti tensioni nominali da specificare per il motore sono indicate nella tabella seguente:

US power mains voltages and the corresponding rated voltages to be specified for the motor are indicated in the following table:

Die Spannungen der amerikanischen Verteilernetze und die entsprechenden Nennspannungen, die bei der Bestellung der Motore angegeben werden müssen, können der folgenden Tabelle entnommen werden:

Les tensions des réseaux de distribution américains ainsi que les tensions nominales à spécifier pour le moteur sont indiquées dans le tableau suivant :

(10)	Frequenza Frequency Frequenz Fréquence	Tensione di rete Mains voltage Netzspannung Tension de réseau	Tensione nominale motore Motor rated voltage Nennspannung des Motors Tension nominale moteur
60 Hz		208 V	200 V
		240 V	230 V
		480 V	460 V
		600 V	575 V

I motori dotati di collegamento YY/Y (es. 230/460-60; 220/440-60) presentano di serie una morsetteria a 9 terminali. Per le stesse esecuzioni, e inoltre per l'alimentazione 575V-60Hz, la potenza di targa corrisponde a quella normalizzata a 50Hz. Per i motori autofrenanti con freno in c.c. tipo BN_FD l'alimentazione del raddrizzatore è da morsetteria motore con tensione 230V a.c. monofase.

Motors with YY/Y connection (e.g. 230/460-60; 220/440-60) feature, as standard, a 9-stud terminal board. For same executions, as well as for 575V-60Hz supply, the nominal rating is coincident with the correspondent 50Hz rating. For DC brake motors type BN_FD, the rectifier is connected to a single-phase 230 VAC supply voltage in the motor terminal box.

Motoren mit YY/Y-Anschluss (z.B. 230/460-60; 220/440-60) sind standardmäßig mit 9 Pins auf dem Klemmbrett ausgeführt. Für gleiche Ausführungen, ebenso wie für 575V-60Hz, die Nennleistung ist gleich mit der entsprechenden 50 Hz-Leistung. Für Bremsmotoren mit Gleichstrombremse vom Typ BN_FD erfolgt die Versorgung des Gleichrichters über den Motorklemmenkasten mit einer

Les moteurs avec connexion YY/Y (ex. 230/460-60; 220/440-60) présentent, en standard, une plaque à borne avec 9 bornes. Pour les mêmes executions, et aussi pour l'alimentation 575V-60Hz, la puissance de plaque correspond à celle normalisé à 50Hz. Pour les moteurs frein avec frein en c.c. type BN_FD , l'alimentation du redresseur provient de la boîte à bornes moteur avec une tension 230V c.a. monophasée.

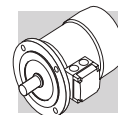

Per i motori autofrenanti l'alimentazione del freno è così predisposta:

Brake power supply for brake motors is as follows:

Spannung von 230V (einphasiger Wechselstrom). Bei Bremsmotoren stellt sich die **Versorgung der Bremse** wie folgt dar:

Pour les moteurs frein l'alimentation du frein est la suivante :

(11)	BN_FD	BN_FA ; BN_BA	Specificare: Power supply: Bitte angeben: Spécifier :
	Da morsettiera motore <i>Connected to terminal box</i> Vom Motorklemmenkasten <i>Depuis boîte à bornes moteur</i>	Alimentazione separata <i>Separate power supply</i> Fremdversorgung <i>Alimentation séparée</i> 230 V Δ - 60 Hz	230SA
	1~ 230 V a.c.	Alimentazione separata <i>Separate power supply</i> Fremdversorgung <i>Alimentation séparée</i> 460 V Y - 60 Hz	460SA

L'opzione CUS non è applicabile ai motori dotati di servoventilazione.

The option CUS does not apply to servo-ventilated motors.

Die CUS-Option ist für die Fremdlüftermotoren nicht anwendbar

L'option CUS n'est pas applicable aux moteurs doués de ventilation forcée.

M8 - ALIMENTAZIONE DA INVERTER

I motori elettrici della serie BN possono essere utilizzati con alimentazione da inverter PWM e tensione nominale all'ingresso del convertitore fino a 500 V.

Il sistema isolante adottato sui motori di serie prevede l'isolamento di fase con separatori, l'utilizzo di filo smaltato in grado 2 e resine d'impregnazione in classe H (limite di tenuta all'impulso di tensione 1600V picco-picco e fronte di salita $t_s > 0.1 \mu s$ ai morsetti motore).

Le caratteristiche tipiche coppia/velocità in servizio S1 per motore con frequenza base $f_b = 50$ Hz sono riportate nella tabella seguente.

Per frequenze di funzionamento inferiori a circa 30 Hz, a causa della diminuzione della ventilazione, i motori standard autoventilati (IC 411) devono essere opportunamente declassati in coppia o, in alternativa, devono essere provvisti di ventilatore con alimentazione separata (vedi par. M12).

Per frequenze maggiori alla frequenza base, raggiunto il valore massimo di tensione di uscita dell'inverter, il motore lavora in un campo di funzionamento a

M8 - INVERTER CONTROL

The BN type electric motors are suitable for PWM inverter control with rated voltage at transformer input up to 500 V.

The insulating system adopted on standard motors uses phase insulation with separators, grade 2 enamelled wire and impregnation resins in class H (maximum voltage pulse 1600 V peak-to-peak and rise edge $t_s > 0.1 \mu s$ at motor terminals).

Typical torque/speed characteristics for S1 duty for motors operating with basic frequency $f_b = 50$ Hz is reported in the table below.

Operating at the frequencies below 30 Hz impair ventilation efficiency, standard motors with incorporated fan (IC 411) require either a corresponding torque reduction or, alternately, a fan with separate power supply. (See par M12)

For frequencies greater than basic frequency, once inverter maximum output voltage has been reached, the motor will be working in a steady power operation range, with shaft torque decreasing approximately with ratio (f/f_b) .

As motor maximum torque de-

M8 - FREQUENZUMRICHTERBETRIEB

Die Elektromotoren der Serie BN können mit einem Frequenzumrichter und einer Nennspannung am Eingang des Umrichters bis zu 500 V versorgt werden.

Die Motoren haben eine Phasentrennung über Wicklungstrenner, Emaildraht der Klasse 2 mit Imprägnierharzen der Klasse H vor (Widerstandsgrenze gegen einen Spannungsimpuls von 1600 V und Anstiegsrampe $t_s > 0.1 \mu s$ an den Motorklemmen).

Die typischen Merkmale Drehmoment/Drehzahl in der Betriebsart S1 für Motoren mit einer Eckfrequenz von $f_b = 50$ Hz werden in der nachstehenden Tabelle angegeben. Bei Frequenzen von unter 30 Hz liegenden Betriebsfrequenzen müssen die eigenbelüfteten Standardmotoren (IC 411) aufgrund ihrer geringeren Kühlwirkung in ihrem Drehmoment zurückgestuft oder, alternativ, mit einem Fremdlüfter ausgestattet werden (siehe Par. M12).

Wenn der Motor oberhalb der Eckfrequenz betrieben wird, arbeitet er im Feldschwächebereich. In diesem Bereich kon-

M8 - ALIMENTATION PAR VARIATEUR

Les moteurs électriques de la série BN peuvent être utilisés avec alimentation par variateur PWM, et tension nominale en entrée du convertisseur jusqu'à 500V. Le système isolant adopté sur les moteurs de série prévoit l'isolation de phase avec séparateurs, l'utilisation de fil émaillé niveau 2 et résines d'impregnation de classe H (limite de maintien à l'impulsion de tension 1600V pic-pic et front de montée $t_s > 0.1 \mu s$ aux bornes moteur).

Les caractéristiques typiques couple/vitesse en service S1 pour moteur avec fréquence de base $f_b = 50$ Hz sont indiquées dans le tableau suivant. Pour des fréquences de fonctionnement inférieures à environ 30 Hz, à cause de la diminution de la ventilation, les moteurs standards autoventilés (IC411) doivent être opportunément déclassés au niveau du couple ou, en alternative, doivent être équipés de ventilateur avec alimentation séparée (voir paragraphe M12).

Pour des fréquences supérieures à la fréquence de base, une fois la valeur maximale de tension de sortie du variateur atteinte, le moteur fonctionne dans une plage

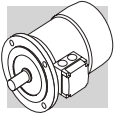

potenza costante, con coppia all'albero che si riduce ca. con il rapporto (f/f_b) . Poiché la coppia massima del motore decresce ca. con $(f/f_b)^2$, il margine di sovraccarico ammesso dovrà essere progressivamente ridotto.

creases approximately with $(f/f_b)^2$, the permitted overload reserve will have to be reduced gradually.

stanter Leistung fällt das Drehmoment des Motors ungefähr um das Verhältnis (f/f_b) ab. Da die maximale Motordrehzahl sich mit ungefähr $(f/f_b)^2$ verringert, muss die zulässige Belastungsgrenze in progressiv reduziert werden.

de fonctionnement à puissance constante, avec un couple à l'arbre qui se réduit approximativement dans le rapport (f/f_b) . Etant donné que le couple maximum du moteur diminue approximativement en relation avec $(f/f_b)^2$, la marge de surcharge admise devra être progressivement réduite.

(12)

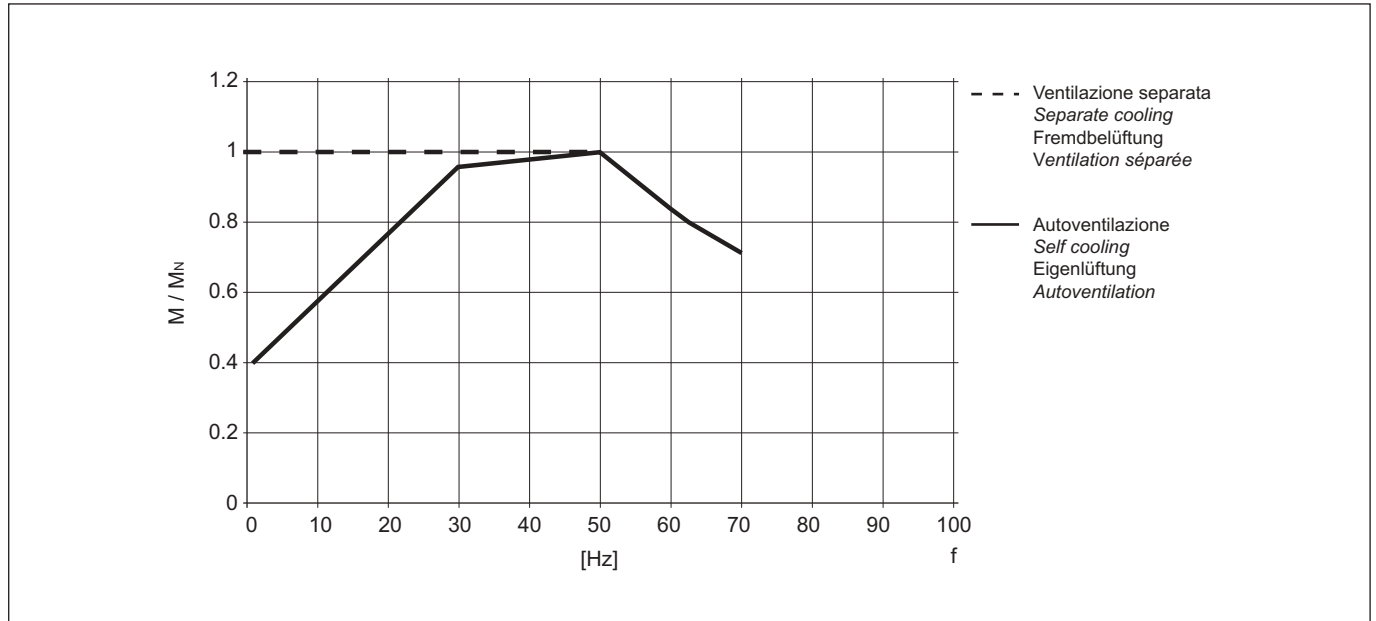

Per funzionamento oltre la frequenza nominale, la velocità limite meccanica dei motori è riportata nella tabella qui di seguito:

The following table reports the mechanical speed limit for motors operating above rated frequency:

Für Anwendungen, bei denen der Motor oberhalb der Eckfrequenz betrieben wird, finden sie die mechanische Drehzahlgrenzen in der folgenden Tabelle:

En cas de fonctionnement au-delà de la fréquence nominale, la vitesse limite mécanique des moteurs est indiquée dans le tableau suivant :

(13)

	n [min ⁻¹]		
	2P	4P	6P/8P
BN 56...BN 100	5200	4000	3000
BN 112	5200	4000	3000
BN 132...BN 160MR	4500	4000	3000
BN 160M...BN 180M	4500	4000	3000
BN 180L...BN 200L	4500	3600	3000

A velocità superiori alla nominale i motori presentano maggiori vibrazioni meccaniche e rumorosità di ventilazione; è consigliabile, per queste applicazioni,

Motors operating above rated speed show an increased tendency for mechanical vibration and fan noise. When this is the case, rotor balancing in grade R

Bei Drehzahlen oberhalb der Nenndrehzahlen weisen die Motoren stärkere mechanische Schwingungen und Lüftunggeräusche auf: In diesen Fällen

A des vitesses supérieures à la vitesse nominale, les moteurs présentent plus de vibrations mécaniques et de bruit de ventilation ; pour ces applications, il

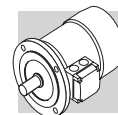

un bilanciamento del rotore in grado R - opzione **RV** - ed eventualmente il ventilatore con alimentazione separata - opzioni **U1** o **U2**.

Sia il servomotorio, sia il freno elettromagnetico, devono sempre essere alimentati direttamente dalla rete.

- *option RV - and possibly a fan with separate power supply - options U1 or U2 - should be specified.*

Both servo-fan and electromagnetic brake require direct connection to mains power supply.

wird das Auswuchten des Rotors im Grad R – Option **RV** – und eventuell die Installation eines Fremdlüfters– Option **U1** oder **U2** - empfohlen. Sowohl der Fremdlüfter als auch die elektromagnetische Bremse müssen bei Frequenzumrichterbetrieb auf Grund der abfallenden Versorgungsspannung immer direkt über das Stromnetz versorgt werden.

est conseillé d'effectuer un équilibrage du rotor en niveau R - option RV - et de monter éventuellement un ventilateur avec alimentation séparée – options U1 ou U2.

Le servomoteur ainsi que le frein électromagnétique doivent toujours être alimentés directement par le réseau.

M9 - TIPO DI SERVIZIO

Se non indicato diversamente, la potenza dei motori riportata a catalogo si riferisce al servizio continuo S1.

Per i motori utilizzati in condizioni diverse da S1 sarà necessario identificare il tipo di servizio previsto con riferimento alle Norme CEI EN 60034-1.

In particolare per servizi S2 ed S3 è possibile ottenere una maggiorazione della potenza rispetto a quella prevista per il servizio continuo secondo quanto indicato nella tabella che segue, valida per i motori a singola polarità.

Per le maggiorazioni applicabili a motori a doppia polarità consultare preferibilmente il Servizio Tecnico Bonfiglioli.

M9 - TYPE OF DUTY

Unless otherwise specified, catalogue motor power refers to continuous duty S1.

Any operating conditions other than S1 duty must be identified in accordance with duty cycle definitions laid down in standards CEI EN 60034-1.

For duty cycles S2 and S3, the power increase co-efficient reported in the following table may be used. Please note that the table provided below applies to single-speed motors.

Please contact Bonfiglioli Engineering for the power increase coefficients applicable to switch-pole motors.

M9 - BETRIEBSARTEN

Sofern nicht anderweitig angegeben, beziehen sich die im Katalog angegebene Motorleistungen auf den Dauerbetrieb S1. Bei Motoren, die unter Bedingungen eingesetzt werden, die nicht mit S1 übereinstimmen, muss die entsprechende Betriebsart unter Bezugnahme auf die Normen CEI EN 60034-1 festgelegt werden. Insbesondere kann man, für die Betriebsarten S2 und S3, durch Anwendung der in der nachstehenden Tabelle angeführten Koeffizienten der für den Dauerbetrieb vorgesehenen Leistung gegenüber eine Leistungssteigerung erzielen. Diese Tabelle gilt für einpolige Motoren. Für die polumschaltbaren Motoren sollte man sich im Hinblick auf den Leistungssteigerung, mit unserem Technischen Kundendienst in Verbindung setzen.

M9 - TYPE DE SERVICE

Sauf indication contraire, la puissance des moteurs indiquée dans le catalogue se réfère au service continu type S1.

Pour les moteurs utilisés dans des conditions différentes de S1, il est nécessaire d'identifier le type de service en se référant aux Normes CEI EN 60034-1. Plus particulièrement, pour les types de service S2 et S3 il est possible d'obtenir une majoration de la puissance par rapport à celle prévue pour le service continu, en appliquant les coefficients indiqués dans le tableau suivant, valable pour les moteurs à simple polarité. En ce qui concerne les majorations applicables aux moteurs à double polarité, il est préférable de contacter le Service Technique Bonfiglioli.

S2

Funzionamento a carico costante per un periodo di tempo limitato, inferiore a quello richiesto per raggiungere l'equilibrio termico, seguito da un periodo di riposo di durata sufficiente a ristabilire nel motore la temperatura ambiente.

Operation under steady loading for a limited period of time (less than the time taken to achieve thermal balance), followed by a period of time at rest long enough for engine to cool down to ambient temperature.

Betrieb mit konstanter Last für eine begrenzte Dauer, die unter der Zeit liegt, die für das Erreichen des thermischen Gleichgewichts erforderlich ist, gefolgt von einer Aussetzzeit mit einer Dauer, die für das erneute Erreichen der Umgebungstemperatur im Motor erforderlich ist.

Fonctionnement à charge constante pendant une période de temps limitée, inférieure à celle nécessaire pour atteindre l'équilibre thermique, suivie par une période de repos de durée suffisante pour rétablir la température ambiante dans le moteur.

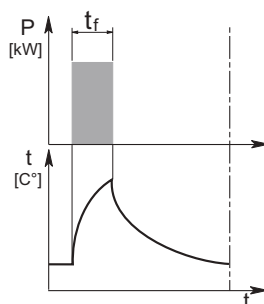

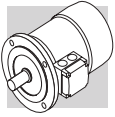

S3

Sequenza di cicli di funzionamento identici, ciascuno comprendente un periodo di funzionamento a carico costante ed un periodo di riposo. In questo tipo di servizio la corrente d'avviamento non influenza la sovratemperatura in modo significativo.

A sequence of identical operation cycles, each including operation under steady loading followed by some time at rest. In this type of duty, starting current has no significant effect on overtemperature.

Betriebsweise mit identischen Betriebszyklen, von denen jeder Zyklus eine Betriebsdauer mit konstanter Last und eine Aussetzzeit einschliesst. Bei dieser Betriebsart beeinflusst der Anlaufstrom die Übertemperatur in keinerlei ausschlaggebender Weise.

Séquence de cycles de fonctionnement identiques, comprenant chacun une période de fonctionnement à charge constante et une période de repos. Dans ce type de service, le courant de démarrage n'influence pas l'excès de température de façon significative.

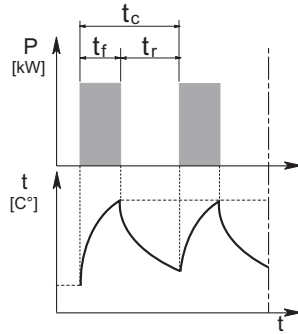

(14) Tipo di Servizio Type of duty Betriebsart Type de service	Potenza ammissibile in p.u. della potenza in S1 Permitted power in p.u. of S1 power Zulässige Leistung in % der Leistung bei S1 Puissance admissible en p.u. de la puissance en S1	
	Durata / Duration / Dauer / Durée	
S2	10 min	1.35
	30 min	1.15
	60 min	1.05
	Rapporto di intermittenza Intermittence / Schaltverhältnis Rapport d'intermittence (I)	
S3	25 %	1.25
	40 %	1.15
	60 %	1.10
S4 ... S9	Interpellarci / Contact us / Setzen Sie sich mit uns in Verbindung / Nous contacter	

$$I = \frac{t_f}{t_f + t_r} \cdot 100$$

t_f = tempo di funzionamento sotto carico
 t_r = tempo di riposo

t_f = work time under constant load
 t_r = rest time

t_f = Betriebszeit mit konstanter Last
 t_r = Aussetzzeit

t_f = temps de fonctionnement à charge constante
 t_r = temps de repos

La durata del ciclo dovrà essere ≤ 10 min. Per durate superiori interpellarci.

Cycle duration must be up to 10 min. Please contact us when cycle duration exceeds this limit.

Die Zyklusdauer muss ≤ 10 min. betragen. Falls der Zyklus länger sein sollte, setzen Sie sich bitte mit unserem Kundendienst in Verbindung.

La durée du cycle devra être ≤ 10 min. Pour des durées supérieures, nous contacter.

M10 - MORSETTIERA MOTORE

M10 - TERMINAL BOX

M10 - MOTORKLEMMENKASTEN

M10 - BORNIER MOTEUR

La morsettiera principale è a 6 morsetti per collegamento con capicorda (esecuzione a 9 morsetti per tensioni americane "dual voltage" - vedi par. M7.1). All'interno della scatola copri-

The main terminal box has 6 terminals for connection to lead-in wires (9-terminal version is supplied for "dual voltage" US voltage ratings - see M7.1). The ground terminal for earth

Der Klemmenkasten hat ein Klemmbrett mit 6 Klemmen für einen Anschluss über Kabelschuhe (für die amerikanischen Spannungswerte "dual voltage" sind 9 Klemmen vorgesehen – siehe

Le bornier principal est de type à 6 bornes pour raccordement avec cosses (exécution à 9 bornes pour les tensions américaines "dual voltage" – voir M7.1). A l'intérieur du couvercle du

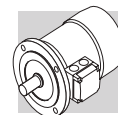

morsetti è previsto il morsetto di terra per il collegamento del conduttore di protezione.

Le dimensioni dei terminali sono riportati nella tabella (15). Per l'alimentazione del freno vedi par. M25 (freno FD), M26 + M27 (freno FA e BA).

Nei motori in forma costruttiva IM B3 la scatola coprimorsetti è posta in alto (posizione opposta ai piedi).

Eseguire i collegamenti elettrici secondo gli schemi riportati all'interno della scatola coprimorsetti o nei manuali d'uso.

lead connection is housed in the terminal box.

Terminal sizes are listed in the table (15).

For brake power supply, please read par. M25 (brake FD), M26 + M27 (brake FA and BA).

In motor design IM B3, the terminal box is top mounted (side opposite to feet).

Please refer to the wiring diagrams reported inside the terminal box, or in the operating instructions, for correct wiring.

M7.1. Im Inneren des Klemmenkastens ist ein Erdungsanschluß für den Anschluss des Schutzleiters vorgesehen. Die Abmessungen der Anschlüsse werden in der Tabelle (15) angegeben. Für Informationen über die Bremsversorgung verweisen wir an dieser Stelle auf den Par. M25 (Brems-typ FD), M26 + M27 (Brems-typ FA und BA). Bei Motoren in der Bauform IM B3 ist der Klemmenkasten oben angeordnet (den Fü-ßen entgegengesetzt).

Die elektrischen Anschlüsse müssen entsprechend den Schaltplänen, die sich im Inneren des Klemmenkästen befinden oder in den Betriebsanleitungen zu finden sind, vorgenommen werden.

bornier se trouve la borne de terre pour le raccordement du conducteur de protection.

Les dimensions des bornes sont indiquées dans le tableau (15). Pour l'alimentation du frein, voir par. M25 (frein FD), M26 + M27 (frein FA et BA). Sur les moteurs de forme de construction IM B3 la boîte à bornes est située en haut (à l'opposé des pieds).

Effectuer les branchements électriques selon les schémas indiqués à l'intérieur du couvercle de la boîte à bornes ou dans les manuels d'instructions.

(15)

	N° terminali No. of terminals Klemmen N° bornes	Filettatura terminali Terminal threads Gewinde Filetage bornes	Sezione max. del conduttore mm ² Wire max cross section area sq mm ² Max. leiter-querschnitt mm ² Section max du conducteur mm ²
BN 56 ... BN 90	6	M4	2.5
BN 100 ... BN 160MR	6	M5	6
BN 160M ... BN 180M	6	M6	16
BN 180L ... BN 200L	6	M8	25

M10.1 - INGRESSO CAVI

Nell'esecuzione standard l'ingresso dei cavi di alimentazione è previsto per pressacavo metrici in accordo alla Norma CEI EN 50262. Dimensioni e disposizioni come indicato nelle tabelle che seguono.

M10.1 - CABLE GLAND HOLES

Standard cable gland holes accommodate metric-size cable glands in accordance with standard CEI EN 50262. Dimensions and locations are as shown in the following tables.

M10.1 - KABELDURCHFÜHRUNG

In der Standardversion ist die Ein- bzw. Durchführung der Kabel in Übereinstimmung mit der Norm CEI EN 50262 über metrische Kabelführungen vorgesehen. Maße und Anordnung werden in den folgenden Tabellen angegeben.

M10.1 - ENTREE CABLES

Dans l'exécution standard, l'entrée des câbles d'alimentation est prévue pour des serre-câbles métriques, en accord avec la Norme CEI EN 50262. Dimensions et dispositions comme indiqué dans les tab. suivantes.

(16)

Motori flangiati (IM B5, IM B14) / Flanged motors (IM B5, IM B14) Flanschmotoren (IM B5, IM B14) / Moteurs à bride (IM B5, IM B14)			
	N° ingresso cavi e dimensione No. & size of cable gland holes Kabeleingänge und masse Nb entrees câbles et dimensions		Ø Max. cavo [mm] Wire max Ø [mm] Max. Ø kabel [mm] Ø Max câble [mm]
BN 56 ... BN 63	2 x M 20 x 1.5	1 foro per lato 1 Hole on each side 1 Bohrung pro Seite 1 Orifice par côté	13
BN 71 ... BN 90	2 x M 25 x 1.5		17
BN 100	2 x M 32 x 1.5 2 x M 25 x 1.5	2 fori per lato 2 Holes on each side 2 Bohrungen pro Seite 2 Orifices par côté	21 17
BN 112	2 x M 32 x 1.5 2 x M 25 x 1.5		17
BN 132 ... BN 160MR	4 x M 32 x 1.5		21
BN 160M ... BN 200L	2 x M 40 x 1.5	Orientabili 4 x 90° Pivoting, 4 x 90° Orientierbar 4 x 90° Orientables 4 x 90°	28

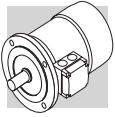

(17)

Motori con piedi (IM B3 e derivati) / Footed motors (IM B3 and derived designs) Motoren in Fußausführung (IM B3 und davon abgeleitete Versionen) Moteurs avec pieds (IM B3 et dérivés)			
	N° ingresso cavi e dimensione no. & size of cable gland holes Kabeleingänge und masse nb entrees câbles et dimensions		Diametro max. cavo [mm] max wire diameter Ø [mm] Max. Ø kabel [mm] Ø max câble [mm]
BN 63	2 x M 16 x 1.5	1 foro per lato 1 hole on each side	10
BN 71 ... BN 80	2 x M 20 x 1.5	1 Bohrung pro Seite 1 orifice par côté	13
BN 90	2 x M 25 x 1.5		17
BN 100 ... BN 112	4 x M 25 x 1.5	2 fori per lato 2 holes on each side	17
BN 132	4 x M 32 x 1.5	2 Bohrungen pro Seite 2 orifices par côté	21

M11 - FORME COSTRUTTIVE

I motori sono previsti nelle forme costruttive IM B3, IM B5, IM B14 e derivate in accordo alla Norma CEI EN 60034-7, come indicato nella tabella seguente.

M11 - DESIGN VERSIONS

Motors are available in the design versions IM B3, IM B5, IM B14 and derived versions in accordance with standard CEI EN 60034-7, as outlined in the table below.

M11 - BAUFORMEN

Die Motoren sind in den Bauformen IM B3, IM B5, IM B14 und abgeleitete Versionen erhältlich und wurden in Übereinstimmung mit der Norm CEI EN 60034-7, entsprechend den Angaben in der nachstehenden Tabelle, realisiert.

M11 - FORMES DE CONSTRUCTION

Les moteurs sont disponibles dans les formes de construction IM B3, IM B5, IM B14 et dérivées, en accord avec la Norme CEI EN 60034-7, comme indiqué dans le tableau suivant.

(18)

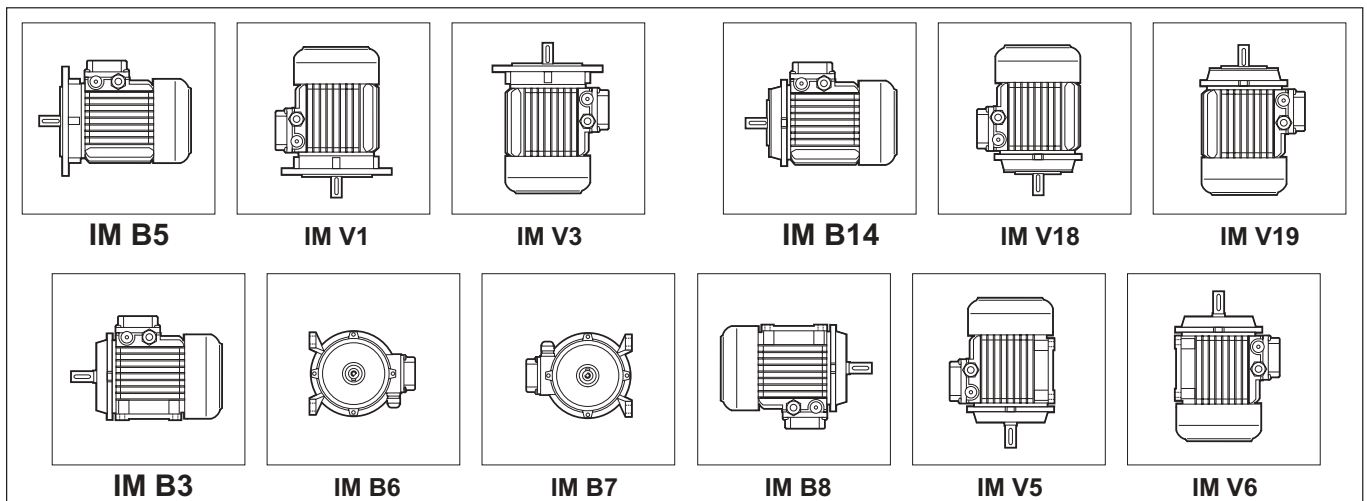

I motori, targati esclusivamente nella forma costruttiva base, possono essere installati anche nelle forme costruttive derivate, come illustrato nella tabella seguente:

Motors in the derived design versions may also be installed as outlined in the table below. however, note that motor name plate will report the corresponding basic design version:

Die Motoren werden auf dem Typenschild in der Einbaulage B3 angegeben, sie können aber auch in den anderen, in der nachfolgenden Tabelle angegebenen Bauformen montiert werden:

Les moteurs, marqués exclusivement dans la forme de construction de base, peuvent aussi être installés dans les formes de construction dérivées, comme indiqué dans le tableau suivant :

(19)

Forma costruttiva base Basic design version Gundbauf orm Forme de construction de base	Forma costruttiva derivata / Derived design version Andere Einbaulagen / Forme de construction dérivée				
IM B3	IM B6	IM B7	IM B8	IM V5	IM V6
IM B5	IM V1	IM V3			
IM B14	IM V18	IM V19			

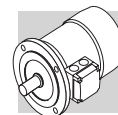

Nelle installazioni con l'albero rivolto verso il basso è consigliabile specificare l'opzione **RC** - tettuccio parapiooggia, vedi par. M23 in particolar modo nel caso di motore autofrenante.

I motori in forma flangiata possono essere forniti con dimensioni di accoppiamento ridotte, corrispondenti alle forme costruttive B5R o B14R, con dimensioni dettagliate nella tabella seguente:

If motor is to be installed with the shaft pointing downwards, the rain canopy option RC – see par. M23 is recommended, especially where a brake motor is used.

Flange output motors are also available with reduced coupling dimensions corresponding to design versions B5R or B14R. Dimensions are indicated in the table below:

Bei Anwendungen mit senkrecht unten zeigender Welle, wird empfohlen, den Motor mit der Option **RC** – Schutzdach, siehe M23 zu bestellen, insbesondere dann, wenn es sich um einen Bremsmotor handelt. Die Motoren mit Flansch können mit reduzierten Wellen- und Flanschmaßen geliefert werden, die den Bauformen B5R oder B14R entsprechen und folgende Maße aufweisen:

En ce qui concerne les installations avec arbre dirigé vers le bas, il est conseillé de spécifier l'option RC – capot antipluie, voir par. M23 plus particulièrement en cas de moteur frein. Les moteurs avec bride peuvent être fournis avec des dimensions d'accouplement réduites, correspondant aux formes de construction B5R ou B14R, avec les dimensions détaillées dans le tableau suivant :

(20)

	BN 71	BN 80	BN 90	BN 100	BN 112	BN 132
	DxE - Ø					
B5R ⁽¹⁾	11x23 - 140	14x30 - 160	19x40 - 200	24x50 - 200	24x50 - 200	28x60 - 250
B14R ⁽²⁾	11x23 - 90	14x30 - 105	19x40 - 120	24x50 - 140	—	—

⁽¹⁾ Flangia con fori passanti
⁽²⁾ Flangia con fori filettati

⁽¹⁾ Flange with through holes
⁽²⁾ Flange with tapped holes

⁽¹⁾ Flanschen mit durchgehenden Bohrungen
⁽²⁾ Flansch mit Gewindebohrungen

⁽¹⁾ Bride avec orifices passants
⁽²⁾ Bride avec orifices filetés

M12 - VENTILAZIONE

I motori sono raffreddati mediante ventilazione esterna (IC 411 secondo CEI EN 60034-6) e sono provvisti di ventola radiale in plastica, funzionante in entrambi i versi di rotazione.

L'installazione dovrà assicurare una distanza minima della calotta copriventola dalla parete più vicina, in modo da non creare impedimento alla circolazione dell'aria, oltre che permettere l'esecuzione della manutenzione ordinaria del motore e, se presente, del freno.

Su richiesta, a partire dalla grandezza BN 71, i motori possono essere forniti con ventilazione forzata ad alimentazione indipendente. Il raffreddamento è realizzato per mezzo di un ventilatore assiale con alimentazione indipendente, montato sulla calotta copriventola (metodo di raffreddamento IC 416).

M12 - VENTILATION

Motors are cooled by external ventilation systems (IC 411 in accordance with CEI EN 60034-6) and are equipped with a plastic radial fan running in both directions of rotation.

Installation must take into account a minimum distance of the fan cover from the nearest wall so as to ensure unobstructed air circulation. This also facilitates routine maintenance operations for motor and brake (if fitted).

At request, motor frame sizes BN 71 and larger may be equipped with forced ventilation with independent power supply. Motor is cooled by an axial ventilator mounted on the fan cover using an independent power supply (cooling method IC 416).

M12 - KÜHLUNG

Die Motoren werden mittels Eigenbelüftung gekühlt (IC 411 gemäß CEI EN 60034-6) und sind mit einem Radiallüfterrad aus Kunststoff ausgestattet, das in beide Richtungen drehen kann. Bei der Montage des Motors muss darauf geachtet werden, das zwischen Lüfterhaube und dem nächsten Bauteil eine Mindestabstand einzuhalten, damit die Luftzirkulation nicht beeinträchtigt werden kann. Dieser Abstand ist ebenso für die regelmäßige Instandhaltung des Motors und, falls vorhanden, der Bremse erforderlich. Ab der Baugröße BN 71 können die Motoren auf Anfrage mit einem unabhängig gespeisten Fremdlüfter geliefert werden. Die Kühlung erfolgt hier durch einen Axialventilator, der an Stelle der Standardlüfterhaube (Kühlmethode IC 416) montiert wird.

M12 - VENTILATION

Les moteurs sont refroidis par ventilation externe (IC 411 selon CEI EN 60034-6) et sont équipés de ventilateur radial en plastique fonctionnant dans les deux sens de rotation.

L'installation doit garantir une distance minimum du capot cache-ventilateur par rapport au mur le plus proche de façon à ne pas créer d'empêchement à la circulation de l'air ainsi que pour permettre les interventions d'entretien ordinaire du moteur et, si présent, du frein. Sur demande, à partir de la taille BN 71, les moteurs peuvent être fournis avec ventilation forcée à alimentation indépendante. Le refroidissement est réalisé au moyen d'un ventilateur axial avec alimentation indépendante monté sur le capot cache-ventilateur (méthode de refroidissement IC 416).

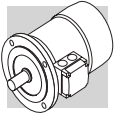

Questa esecuzione è utilizzata in caso di alimentazione del motore tramite inverter allo scopo di estendere il campo di funzionamento a coppia costante anche a bassa velocità, o quando per lo stesso sono richieste elevate frequenze di avviamento. Da questa opzione sono esclusi i motori autofrenanti tipo BN_BA e motori con doppia sporgenza d'albero (opzione PS).

This design is adopted on inverter-controlled motors in order to extend torque-control operating range to include low speeds, or when the motor is to perform a large number of starts per hour. This option is not compatible with brake motors type BN_BA and motors with double-extended shaft (option PS).

Diese Ausführung sollte eingesetzt werden, falls der Motor über einen Frequenzumrichter betrieben wird, so dass der Motor bei konstantem Drehmoment auch bei niedrigen Drehzahlen oder bei hohen Anlauf Frequenzen eingesetzt werden kann. Von dieser Option ausgeschlossen sind die Bremsmotoren BN_BA und Motoren mit zweitem Wellenende (Option PS).

Cette exécution est utilisée en cas d'alimentation du moteur par variateur dans le but d'étendre aussi la plage de fonctionnement à couple constant aux faibles vitesses ou lorsque des fréquences de démarrage élevées sont nécessaires à celui-ci. Les moteurs frein type BN_BA et les moteurs avec arbre sortant des deux côtés (option PS) sont exclus de cette option.

Tabella dati di alimentazione elettrica *Power supply chart*

Tabelle – Daten der Stromversorgung

Tableau caractéristiques de l'alimentation électrique

(21)

BN  U1	V a.c. ± 10%	Hz	P [W]	I [A]
BN 71	1 ~ 230	50 / 60	22	0.14
BN 80			22	0.14
BN 90			40	0.25
BN 100			50	0.25
BN 112	3 ~ 230Δ / 400Y	50	50	0.26 / 0.15
BN 132 ... BN 160MR			110	0.38 / 0.22
BN 160M ... BN 180M			180	1.25 / 0.72
BN 180L ... BN 200L			250	1.51 / 0.87

(22)

BN  U2	V a.c. ± 10%	Hz	P [W]	I [A]
BN 71	1 ~ 230	50 / 60	22	0.14
BN 80			22	0.14
BN 90			40	0.25
BN 100	3 ~ 230Δ / 400Y	50	40	0.24 / 0.14
BN 112			50	0.26 / 0.15
BN 132 ... BN 160MR			110	0.38 / 0.22

Per la variante sono disponibili due esecuzioni alternative, denominate **U1** e **U2**, aventi lo stesso ingombro in senso longitudinale. Per entrambe le esecuzioni, la maggiore lunghezza della calotta copriventola (ΔL) è riportata nella tabella che segue. Dimensioni complessive ricavabili dalle tavole dimensionali dei motori.

*Variant is available in two alternative executions named **U1** and **U2**, featuring the same overall length. The largest length of fan cover (ΔL) for each configuration is reported in the following table. For overall dimensions, please see the dimension tables of motors.*

Für diese Optionsind als Alternative zwei Ausführungen verfügbar: **U1** und **U2** mit dem gleichen Längsmaßen. Für beide Ausführungen wird die Verlängerung der Lüfterhaube (ΔL) in der nachstehenden Tabelle wiedergegeben. Die Gesamtmaße der Motoren können den Tabellen mit den Motormaßen entnommen werden.

*Pour la variante sont disponibles deux exécutions alternatives, dénommées **U1** et **U2**, ayant le même encombrement dans le sens longitudinal. Pour les deux exécutions, la majoration de la longueur du capot cache-ventilateur (ΔL) est indiquée dans le tableau suivant. Dimensions totales à calculer d'après les planches de dimensions des moteurs.*

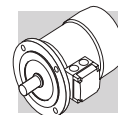

Lunghezza aggiuntiva per motori con ventilazione indipendente

Extra length for motors with independent cooling

Zusätzliche Länge für Motoren mit unabhängiger Luftkühlung

Majoration longueur pour moteurs avec ventilation forcée à alimentation indépendante

(23)

	ΔL_1 [mm]	ΔL_2 [mm]
BN 71	93	32
BN 80	127	55
BN 90	131	48
BN 100	119	28
BN 112	130	31
BN 132 ... BN 160MR	161	51
BN 160M ... BN 180M	184	184
BN 180L ... BN 200L	184	184

ΔL_1 = variazione dimensionale rispetto alla lunghezza LB del motore standard corrispondente.

ΔL_1 = dimension variation compared to length LB of the corresponding standard motor.

ΔL_1 = Maßänderung gegenüber Maß LB des entsprechenden Standardmotors.

ΔL_1 = variation de dimension par rapport à la cote LB du moteur standard correspondant.

ΔL_2 = variazione dimensionale rispetto alla lunghezza LB del motore autofrenante corrispondente.

ΔL_2 = dimension variation compared to length LB of the corresponding brake motor.

ΔL_2 = Maßänderung gegenüber Maß LB des entsprechenden Bremsmotors.

ΔL_2 = variation de dimension par rapport à la cote LB du moteur frein correspondant.

U1

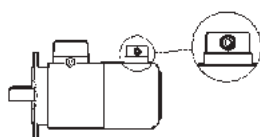

Terminali di alimentazione del ventilatore in scatola morsetti separata. Nei motori autofrenanti grandezza BN 71...BN 160MR, con variante **U1**, la leva di sblocco non è collocabile nella posizione AA (vedi par. M24.1).

L'opzione non è disponibile per i motori conformi alle norme CSA e UL (opzione CUS).

Terminals of the independent fan motor are housed in a separate terminal box. The hand release cannot be located in the AA position for brake motors size BN71...BN160MR that feature the U1 type forced cooling, as described at section M24.1.

The option is not applicable to motors compliant with the CSA and UL norms (option CUS).

Versorgungsanschlüsse des Ventilators im Zusatzklemmenkasten. Bei den Bremsmotoren in der Baugröße BN 71...BN 160MR, mit Variante **U1** kann der Bremslüfthebel nicht in der Position AA (siehe Par. M24.1) angeordnet werden.

Die Option ist nicht anwendbar für die Motoren entsprechend den Normen CSA und UL (Option CUS).

Bornes d'alimentation du ventilateur dans une boîte à bornes séparée. Pour les moteurs frein taille BN 71...BN 160MR, avec variante **U1**, le levier de déblocage ne peut être installé en position AA (voir par. M24.1).

L'option n'est pas disponible pour les moteurs conformes aux normes CSA et UL (option CUS)

U2

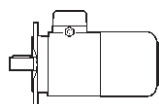

Terminali di alimentazione del ventilatore nella scatola morsetti principale del motore.

L'opzione U2 non è applicabile ai motori BN160M...BN200L e ai motori con l'opzione CUS (conformi alle norme CSA e UL).

Terminals of the fan motor are located in the main terminal box.

The U2 option is not applicable to motors BN160M... BN200L and to motors with option CUS (compliant to norms CSA and UL).

Versorgungsanschlüsse des Ventilators im Hauptklemmenkasten des Motors.

Die Option U2 ist nicht anwendbar bei den Motoren BN160M...BN200L und bei den Motoren mit der CUS-Option (entsprechend den Normen CSA und UL).

Bornes d'alimentation du ventilateur dans la boîte à bornes principale du moteur.

L'option U2 n'est pas applicable aux moteurs BN160M... BN200L et aux moteurs avec l'option CUS (conforme aux normes CSA et UL).

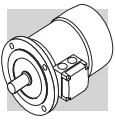

**M13 - DESIGNAZIONE
MOTORE**

**M13 - MOTOR
DESIGNATION**

M13 - MOTORBEZEICHNUNG

**M13 - DESIGNATION
MOTEUR**

MOTORE / MOTOR
MOTOR / MOTEUR

FRENO / BRAKE
BREMSE / FREIN

BN 63B 4 230/400-50 IP55 CLF B5 FD 3.5 R NB 220SA ...

OPZIONI
OPTIONS
OPTIONEN
OPTIONS

111

ALIMENTAZIONE FRENO
BRAKE SUPPLY
BREMSVERSORGUNG
ALIMENTATION FREIN

124

TIPO RADDRIZZATORE AC/DC
RECTIFIER TYPE
GLEICHRICHTERTYP
TYPE ALIMENTATEUR

129

LEVA DI SBLOCCO FRENO
BRAKE HAND RELEASE
BREMSENTHANDLÜFTUNG
LEVIER DE DEBLOCAGE FREIN

122

COPPIA FRENANTE/ BRAKE TORQUE
BREMSMOMENT / COUPLE FREIN

131

135

139

TIPO FRENO / BRAKE TYPE / BRESENTYP / TYPE DE FREIN

127

133

137

FORMA COSTRUTTIVA / MOTOR EXECUTION
BAUFORM / FORME DE CONSTRUCTION

106

CLASSE ISOLAMENTO / INSULATION CLASS
ISOLIERUNGSKLASSE / CLASSE ISOLATION

114

GRADO DI PROTEZIONE / DEGREE OF PROTECTION
SCHUTZART / DEGRE DE PROTECTION

112

TENSIONE-FREQUENZA / VOLTAGE-FREQUENCY
SPANNUNG-FREQUENZ / TENSION-FREQUENCE

95

NUMERO DI POLI / NUMBER OF POLES / POLZAHL / N.bre POLES
2, 4, 6, 8, 2/4, 2/6, 2/8, 2/12, 4/6, 4/8





141

GRANDEZZA MOTORE / MOTOR SIZE / MOTOR-BAUGROSSE / TAILLE MOTEUR
56 - 200L

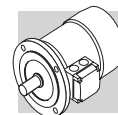











141

BN

M14 - VARIANTI E OPZIONI
**M14 - VARIANTS
AND OPTIONS**
M14 - OPTIONEN
**M14 - VARIANTES
ET OPTIONS**
VARIANTI
VARIANTS
OPTIONEN
VARIANTES

Descrizione Description Beschreibung Description		Default Default Standard Par défaut	Opzione Option Option Option		
Tensione-frequenza Voltage-frequency Spannung-Frequenz Tension-fréquence		230/400-50			 95
Grado di protezione Protection class Schutzart Degré de protection	BN	IP 55	IP 56		 112
	BN_FD BN_FA	IP 54	IP 55		
	BN_BA	IP 55	-		
Classe di isolamento Insulation class Isolierstoffklasse Classe d'isolation		CL F	CLH		 114
Forma costruttiva Design version Bauform Forme de construction		B5	B14	B3	 106

OPZIONI
OPTIONS
OPTIONEN
OPTIONS

Descrizione / Description Beschreibung / Description	Valori / Catalogue numbers Werte / Valeurs			
Protezioni termiche Thermal protective devices Thermische Wicklungsschutz Protections thermiques	D3	E3		 115
Potenza normalizzata a 50 Hz 50 Hz normalized power Auf 50 Hz genormte Leistung Puissance normalisée à 50 Hz	PN			 99
Dispositivi di retroazione Feedback devices Signalrückführungen (Drehgeber) Dispositifs de rétroaction	EN1	EN2	EN3	 117
Riscaldatori anticondensa Anti-condensate heaters Wicklungsheizung Réchauffeurs anticondensation	H1			 118
Tropicalizzazione avvolgimenti Tropicalized windings Tropenschutz der Motorwicklungen Tropicalisation bobinages	TP			 118
Doppia estremità d'albero Double-extended shaft Zweites Wellenende Arbre à double extrémité	PS			 118
Equilibratura rotore in grado R Rotor balancing grade R Rotorauswuchtung mit Grad R Équilibrage rotor en degré R	RV			 119
Protezioni meccaniche esterne External mechanical protections Schutzdächer Protections mécaniques extérieures	RC	TC		 120
Ventilazione forzata Forced ventilation Fremdlüfter Ventilation forcée	U1	U2		 109
Esecuzione certificata Certification Zertifizierte Ausführung Exécution certifiée	 	CUS		 100

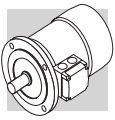

**OPZIONI COLLEGATE
AL FRENO**

BRAKE-RELATED OPTIONS

BREMSEOPTIONEN

**OPTIONS CONCERNANT
LE FREIN**

Descrizione <i>Description</i> <i>Beschreibung / Description</i>	Valori / <i>Catalogue numbers</i> <i>Werte / Valeurs</i>				Pagina
Coppia frenante <i>Brake torque</i> Bremsmoment <i>Couple de freinage</i>	Riferirsi al particolare tipo di freno <i>Refer to brake type</i> Bezug auf den entsprechenden Bremstyp nehmen <i>Se référer au type de frein particulier</i>				131 135 139
Leva di sblocco manuale <i>Manual release lever</i> Manueller Bremsl�fthebel <i>Clevier de d�blocage manuel</i>	R	RM			122
Orientamento leva di sblocco <i>Release lever orientation</i> Orientierung des Bremsl�sehebel <i>Orientation levier de d�blocage</i>	AB	AA	AC	AD	
Alimentatore freno d.c. <i>DC brake rectifier</i> Stromversorgung der Bremse <i>Disp. d'alimentation c.c.</i>	NB	NBR	SB	SBR	129
Volano per avviamento progressivo <i>Soft-start flywheel</i> Schwungrad f�r Sanftanlauf <i>Volant pour d�marrage progressif</i>	F1				126
Filtro capacitivo <i>Capacitive filter</i> Kapazitiver Filter <i>Filtre capacitif</i>	CF				126
Alimentazione freno separata (*) <i>Brake separate power supply (*)</i> Separate Bremsversorgung (*) <i>Alimentation frein s�par�e (*)</i>	...SA	...SD			124

(*) Completare con il valore di tensione.

(*) Specify voltage.

(*) Spannungswert eintragen.

(*) Compl ter avec la valeur de tension.



Valori pre-impostati di default.



Default values.



Standardwerte bei Lieferung falls nicht anders spezifiziert.



Valeurs pr d finies par d faut.

M15 - GRADO DI PROTEZIONE

**M15 - DEGREE
OF PROTECTION**

M15 - SCHUTZART

**M15 - DEGRE
DE PROTECTION**



Nella loro esecuzione standard (non autofrenante) i motori tipo BN sono caratterizzati dal grado di protezione IP55, a richiesta   disponibile la protezione aumentata IP56.

I motori autofrenanti tipo BN_FD e BN_FA sono protetti in grado IP54 e, opzionalmente, in IP55. La tabella sottostante riassume la disponibilit  dei vari gradi di protezione.

Indipendentemente dal grado di protezione specificato, per installazione all'aperto i motori devono essere protetti dall'irraggiamento diretto e, nel caso di installazione con l'albero rivolto verso il basso,   necessario specificare ulteriormente il tettuccio di protezione contro l'ingresso di acqua e di corpi solidi (opzione RC).

Standard BN motors (where standard means other than brake motors) are manufactured in protection class IP55. A higher protection class IP56 is available at request. Brake motors type BN_FD and BN_FA are in protection class IP54 or IP55 (at request).

Brake motors BN_BA are only available in protection class IP55. The following table provides an overview of available protection classes.

Regardless of the protection class specified on order, motors to be installed outdoors require protection against direct sunlight and in addition – when they are to be installed with the shaft pointing downwards – a rain canopy to keep out water and solid bodies (option RC).

In der Standardausf hrung (ohne Bremse) werden die Motoren vom Typ BN in Schutzart IP55 ausgeliefert. Auf Anfrage k nnen sie mit einer auf IP56 erh hten Schutzart geliefert werden. Die Bremsmotoren vom Typ BN_FD und BN_FA verf gen  ber die Schutzart IP54 und k nnen Optional in IP55 geliefert werden. Die Bremsmotoren vom Typ BN_BA sind nur in der Schutzart IP55 lieferbar. In der nachstehenden Tabelle werden die jeweils zur Verf gung stehenden Schutzarten zusammengefasst. Unabh ngig von der spezifischen Schutzart m ssen die im Freien installierten Motoren vor direkten Strahlungen gesch tzt werden. Im Fall einer senkrechten Montage, in der die Welle nach unten gerichtet ist, sollte dar ber hinaus das Schutzdach bestellt werden, das vor dem Eindringen von Wasser und festen Fremdk rpern sch tzt (Option RC).

Dans l'ex cution standard (non frein), les moteurs type BN sont caract ris s par le degr  de protection IP55. Sur demande, la protection major e IP56 est aussi disponible. Les moteurs frein type BN_FD et BN_FA sont prot g s en degr  IP54 et, en option, en IP55. Les moteurs frein type BN_BA sont disponibles uniquement avec degr  de protection IP55. Le tableau ci-dessous r sume la disponibilit  des diff rents degr s de protection. Ind pendamment du degr  de protection sp cifi , en cas d'installation en plein air, les moteurs doivent  tre prot g s des rayons directs du soleil et, en cas d'installation avec arbre dirig  vers le bas, il est n cessaire de sp cifier ult rieurement le capot de protection contre la p n tration de l'eau et des corps solides (option RC).

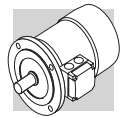

(24)

	IP 54	IP 55	IP 56
BN		standard	
BN_FD BN_FA	standard		
BN_BA		standard	

IP		5	5
0		Non protetto Not protected Nicht geschützt Non protégé	0
1		Protetto contro corpi solidi estranei di $\phi \geq 50$ mm Protected against extraneous solid bodies having $f \geq 50$ mm Geschützt gegen feste Fremdkörper mit $f \geq 50$ mm Protégé contre les corps solides étrangers de $f \geq 50$ mm	1
2		Protetto contro corpi solidi estranei di $f \geq 12,5$ mm Protected against extraneous solid bodies having $f \geq 12,5$ mm Geschützt gegen feste Fremdkörper mit $f \geq 12,5$ mm Protégé contre les corps solides étrangers de $f \geq 12,5$ mm	2
3		Protetto contro corpi solidi estranei di $f \geq 2,5$ mm Protected against extraneous solid bodies having $f \geq 2,5$ mm Geschützt gegen feste Fremdkörper mit $f \geq 2,5$ mm Protégé contre les corps solides étrangers de $f \geq 2,5$ mm	3
4		Protetto contro corpi solidi estranei di $f \geq 1,0$ mm Protected against extraneous solid bodies having $\phi \geq 1,0$ mm Geschützt gegen feste Fremdkörper mit $f \geq 1,0$ mm Protégé contre les corps solides étrangers de $f \geq 1,0$ mm	4
5		Protetto contro la polvere Protected against dust Staubgeschützt Protégé contre la poussière	5
6		Nessun ingresso di polvere No dust ingress Kein Staubeintritt Protection absolue contre la poussière	6
			7
			8

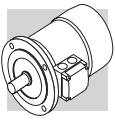

CLF

I motori di produzione Bonfiglioli impiegano, di serie, materiali isolanti (filo smaltato, isolanti, resine d'impregnazione) in classe **F**.

In genere, per i motori in esecuzione standard la sovratemperatura dell'avvolgimento statore è contenuta entro il limite di 80 K, corrispondente alla sovratemperatura di classe B.

L'accurata scelta dei componenti del sistema isolante consente l'impiego dei motori anche in climi tropicali ed in presenza di vibrazioni normali.

Per applicazioni in presenza di sostanze chimiche aggressive o di elevata umidità, è consigliabile contattare il Servizio Tecnico Bonfiglioli per la selezione del prodotto più idoneo.

*Bonfiglioli motors use class **F** insulating materials (enamelled wire, insulators, impregnation resins) as compare to the standard motor.*

In standard motors, stator windings over temperature normally stays below the 80 K limit corresponding to class B over temperature.

A careful selection of insulating components makes the motors compatible with tropical climates and normal vibration.

For applications involving the presence of aggressive chemicals or high humidity, contact Bonfiglioli Engineering for assistance with product selection.

Die Motoren von Bonfiglioli sind serienmäßig mit Isolierstoffen (Emaildraht, Isolierstoffen, Imprägnierharzen) der Klasse **F** ausgestattet.

Allgemein hält sich die Übertemperatur der Motoren in der Standardausführung innerhalb des Grenzwerts von 80 K, der einer Übertemperatur der Klasse B entspricht. Die sorgfältig Wahl der Komponenten des Isoliertesystem gestatten den Einsatz dieser Motoren auch unter tropischen Klimabedingungen und bei Vorliegen normaler Schwingungen.

Für den Einsatz in in der Nähe aggressiv wirkenden chemischen Substanzen oder bei hoher Luftfeuchtigkeit, wird empfohlen sich zur Wahl eines passenden Produktes mit unserem Technischen Kundendienst in Verbindung zu setzen.

*De série, les moteurs fabriqués par Bonfiglioli utilisent des matériaux isolants (fil émaillé, isolants, résines d'impregnation) en classe **F**.*

En général, pour les moteurs en exécution standard, l'échauffement de l'enroulement du stator se situe dans la limite de 80 K, correspondant à un échauffement de classe B.

Le choix soigné des composants du système d'isolation permet d'utiliser également les moteurs dans des climats tropicaux et en présence de vibrations normales.

Pour des applications en présence de substances chimiques agressives, ou d'humidité élevée, il est conseillé de contacter le Service Technique Bonfiglioli pour sélectionner le produit le plus adapté.

CLH

Su richiesta può venire specificata la classe di isolamento **H**.

*Motors manufactured in insulation class **H** are available at request.*

Auf Anfrage können sie auch in der Klasse **H** geliefert werden.

Sur demande, la classe d'isolation H peut être spécifiée.

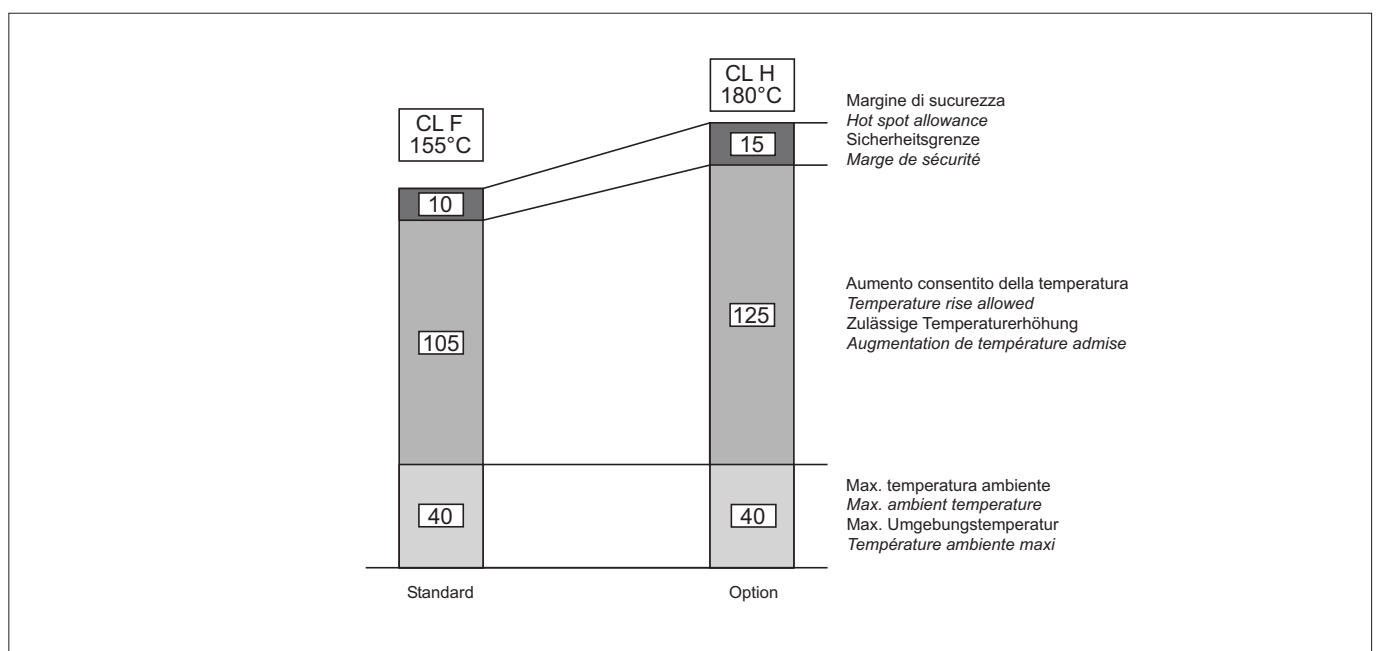

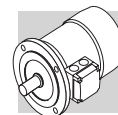

M17- PROTEZIONI TERMICHE

M17- THERMAL PROTECTIVE DEVICES

M17- THERMISCHE WICKLUNGSSCHUTZEINRICHTUNGEN

M17- PROTECTIONS THERMIQUES

Oltre alla protezione garantita dall'interruttore magnetotermico, i motori possono essere provvisti di sonde termiche incorporate per proteggere l'avvolgimento da eccessivo riscaldamento dovuto alla scarsa ventilazione o servizio intermittente. Una protezione aggiuntiva di questo tipo dovrebbe sempre essere specificata per i motori dotati di ventilazione separata. Le varianti a disposizione sono:

The standard thermal cut out fitted to motors may be supplemented by incorporating thermistors or thermostats to protect winding from overheating due to poor ventilation or intermittent duty.

Such additional protection is highly recommended for motors with separate ventilation. Available variants are as follows:

Abgesehen vom durch den Magnetwärmeschalter garantierten Schutz können die Motoren mit integrierten. Temperaturfühler ausgestattet werden, die die Wicklung vor Überhitzung aufgrund einer unzureichenden Lüftung oder eines Aussetzbetriebs sichern. Ein solcher zusätzlicher Schutz sollte bei Motoren mit Fremdlüftung immer verwendet werden. Die verfügbaren Optionen sind:

Outre la protection garantie par le thermocontact moteur, les moteurs peuvent être équipés de sondes thermiques incorporées pour protéger le bobinage contre une surchauffe excessive due à une faible ventilation ou un service intermittent.

Ce type de protection supplémentaire devrait toujours être prévue pour les moteurs dotés de ventilation séparée. Les variantes à disposition sont les suivantes :

D3

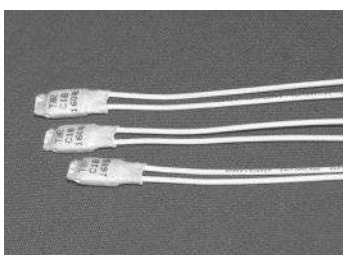

n° 3 sonde bimetalliche negli avvolgimenti con temperatura 150 °C

3 Bi-metallic thermostats in the windings, 150 °C temperature

3 Bimetallfühler in den Wicklungen mit einer Ansprechtemperatur von 150 °C

n° 3 sondes bimétalliques dans les bobinages avec température de 150 °C

I protettori di questo tipo contengono all'interno di un involucro un disco bimetallico che, raggiunta la temperatura nominale di intervento, commuta i contatti dalla posizione di riposo.

Con la diminuzione della temperatura, il disco e i contatti riprendono automaticamente la posizione di riposo.

Normalmente si impiegano tre sonde bimetalliche in serie con contatti normalmente chiusi e terminali disponibili in una morsettiera ausiliaria.

Bimetallic thermostats consist of a bimetallic disc mounted inside a casing. Upon reaching the preset operating temperature, the disc operates the contacts causing them to disengage from the rest position.

As temperature decreases, disc and contacts return to the rest position.

Normally, three bimetallic thermostats connected in series with normally closed contacts and an auxiliary terminal board are used.

Diese Schutzeinrichtungen enthalten in einer Kapsel eine Bimetallscheibe, die bei Erreichen der Nennansprechtemperatur die Kontakte aus ihrer Ruhestellung heraus schaltet. Bei abnehmender Temperatur nehmen die Scheibe und die Kontakte automatisch wieder ihre Ruhestellung ein. Normalerweise werden diese drei Bimetallfühler bei normal geschlossenen Kontakten und auf einer Hilfsklemmenleiste verfügbaren Anschlüsse in Reihe geschaltet.

Les protecteurs de ce type contiennent, dans une enveloppe interne, un disque bimétallique qui, lorsque la température nominale d'intervention est atteinte, commute les contacts de la position de repos.

Avec la diminution de la température, le disque et les contacts reprennent automatiquement la position de repos.

Normalement, on utilise trois sondes bimétalliques en série avec contacts normalement fermés et extrémités disponibles dans une boîte à bornes auxiliaire.

E3

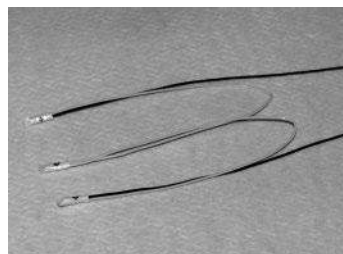

n° 3 termistori PTC negli avvolgimenti, con temperatura 150 °C

3 PTC thermistors in the windings, 150 °C temperature

3 PTC-Thermistoren in den Wicklungen mit einer Ansprechtemperatur 150 °C

3 thermistors PTC dans les bobinages, avec température de 150 °C

I termistori sono semiconduttori che presentano una rapida variazione di resistenza in prossimità della temperatura nominale d'intervento. In genere sono impiegati termistori a coefficiente di temperatura positivo, anche conosciuti con la sigla PTC.

Thermistors are semiconductors that exhibit a rapid resistance change when approaching a preset switch temperature. Normally, positive temperature coefficient (PTC) thermistors are used.

Bei diesen Thermistoren handelt es sich um Halbleiter, die eine schnelle Änderung des Widerstands kurz vor der Nennansprechtemperatur aufweisen. Im allgemeinen werden Thermistoren mit positivem Temperaturkoeffizienten verwendet, die auch unter der Bezeichnung PTC bekannt sind.

Les thermistors sont des semi-conducteurs qui présentent une variation rapide de résistance à proximité de la température nominale d'intervention. En général, on utilise des thermistors à coefficient de température positif, connus aussi sous le sigle PTC.

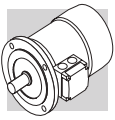

Questi sensori presentano il vantaggio di avere ingombri ridotti, un tempo di risposta molto contenuto e la totale assenza di usura. A differenza delle sonde termiche bimetalliche i termistori non possono comandare direttamente i relais e devono pertanto essere collegati ad una particolare apparecchiatura di sgancio.
I terminali di 3 PTC collegati in serie, sono disponibili in una morsettiera ausiliaria.

These sensors offer such advantages as a compact, space-efficient design, very low response time and totally wear-free operation. Unlike bi-metallic thermostats, thermistors do not operate the relays directly and need to be connected to a special release device for this purpose. The terminals for three PTC thermistors connected in series are available in an auxiliary terminal board.

Diese Sensoren haben den Vorteil kleiner Abmessungen, einer stark eingehaltenen Ansprechzeit und weisen keinerlei Verschleißerscheinungen auf. Im Unterschied zu Bimetall-Temperaturfühlern können diese Thermistoren die Relais nicht direkt schalten und müssen daher an ein spezielles Auslösegerät angeschlossen werden. Die Anschlüsse der 3 in Reihe geschalteten PTC-Thermistoren sind an einer Zusatzklemmleiste verfügbar.

Ces capteurs présentent l'avantage d'être de dimensions réduites, leur temps de réponse est très limité et l'absence d'usure est totale. A la différence des sondes thermiques bimétalliques, les thermistors ne peuvent pas commander directement les relais, par conséquent, ils doivent être branchés à un appareil de déclenchement particulier. Les extrémités de 3 PTC reliés en série sont disponibles dans une boîte à bornes auxiliaire.

M18 - DISPOSITIVI DI RETROAZIONE

M18 - FEEDBACK UNITS

M18 - ENCODER / INKREMENTALGEBER

M18 - DISPOSITIFS DE RETROACTION

EN1, EN2, EN3

BN 63...BN 200L
BN 63_FD...BN 200L_FD
BN 63_FA...BN 200L_FA

EN_ + U1

	L3
BN 160M...BN 180M	72
BN 180L...BN 200L	82
BN 160M_FD...BN 180M_FD	35
BN 180L_FD...BN 200L_FD	41

Se l'opzione EN_ è richiesta per motori di grandezza BN71...BN160MR, contemporaneamente all'opzione U1/U2, le variazioni dimensionali coincidono con quelle dell'opzione U1/U2.

If the encoder device (options EN1, EN2, EN3) is specified on motors BN71...BN160MR, along with the independent fan cooling (options U1, U2), the extra length of motor is coincident with that of the correspondent U1 and U2 execution.

Wenn der Encoder (Optionen EN1, EN2, EN3) für Motoren der Baugrößen BN71...BN160MR zusammen mit Fremdlüftung (Optionen U1, U2) ausgelegt ist, stimmen die Maßänderungen des Motors mit jenen der entsprechenden Ausführungen U1 und U2 überein.

Si un codeur (option EN1, EN2, EN3) est nécessaire sur les moteurs de tailles BN71...BN160MR, en association avec la ventilation forcée (options U1, U2), la variation de dimensions du moteur coïncide avec celle des exécutions U1 et U2 correspondantes.

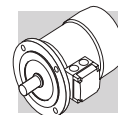

EN1

Encoder incrementale, $V_{IN}= 5$ V, uscita line-driver RS 422. *Incremental encoder, $V_{IN}= 5$ V, line-driver output RS 422.* Inkremental-Encoder, $V_{IN}= 5$ V, Ausgang "line-driver" RS 422. *Codeur incrémental, $V_{IN}= 5$ V, sortie line-driver RS 422.*

EN2

Encoder incrementale, $V_{IN}=10-30$ V, uscita line driver RS 422. *Incremental encoder, $V_{IN}= 10-30$ V, line-driver output RS 422.* Inkremental-Encoder, $V_{IN}=10-30$ V, Ausgang "line-driver" RS 422. *Codeur incrémental, $V_{IN}=10-30$ V, sortie line-driver RS 422.*

EN3

Encoder incrementale, $V_{IN}=12-30$ V, uscita push-pull 12-30 V. *Incremental encoder, $V_{IN}= 12-30$ V, push-pull output 12-30 V.* Inkremental-Encoder, $V_{IN}=12-30$ V, Ausgang "push-pull" 12-30 V. *Codeur incrémental, $V_{IN}=12-30$ V, sortie push-pull 12-30 V.*

Tabella dati tecnici

Specifications

Technische Daten

Tableau des caractéristiques techniques

(25)		EN1	EN2	EN3
Interfaccia <i>Interface</i> Schnittstelle <i>Interface</i>		RS 422	RS 422	push-pull
Tensione alimentazione <i>Power supply voltage</i> Versorgungsspannung <i>Tension d'alimentation</i>	[V]	4...6	10...30	12...30
Tensione di uscita <i>Output voltage</i> Ausgangsspannung <i>Tension de sortie</i>	[V]	5	5	12...30
Corrente di esercizio senza carico <i>No-load operating current</i> Betriebsstrom ohne Belastung <i>Courant d'utilisation sans charge</i>	[mA]	120	100	100
N° impulsi per giro <i>No. of pulses per revolution</i> Impulse pro Drehung <i>Nombre d'impulsions par tour</i>		1024		
n° segnali <i>No. of signals</i> Signale <i>Nombre de signaux</i>		6 (A,B,C + Segnali invertiti / + <i>Inverted signals</i> Invertierte Signale / <i>Signaux inversés</i>)		
Max. frequenza di uscita <i>Max. output frequency</i> Max. Ausgangsfrequenz <i>Fréquence max. de sortie</i>	[kHz]	300	300	200
Max. velocità <i>Max. speed</i> Max. Drehzahl <i>Vitesse max.</i>	[min ⁻¹]	6000 (9000 min ⁻¹ per 10 s) 6000 (9000 rpm for 10 s) 6000 (9000 min ⁻¹ pour 10 s) 6000 (9000 min ⁻¹ für 10 Sek.)		
Campo di temperatura <i>Temperature range</i> Temperaturbereich <i>Plage de température</i>	[°C]	-20 ... +70		
Grado di protezione <i>Protection class</i> Schutzgrad <i>Degré de protection</i>		IP 65		

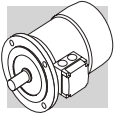

M19 - RISCALDATORI ANTICONDENSA

I motori funzionanti in ambienti molto umidi e/o in presenza di forti escursioni termiche, possono essere equipaggiati con una resistenza anticondensa. L'alimentazione monofase è prevista da morsettiera ausiliaria posta nella scatola principale.

M19 - ANTI-CONDENSATION HEATERS

Where an application involves high humidity or extreme temperature fluctuation, motors may be equipped with an anti-condensate heater. A single-phase power supply is available in the auxiliary terminal board inside the main terminal box.

M19 - WICKLUNGSHEIZUNG

Die Motoren, die in besonders feuchten Umgebungen und/oder unter starken Temperaturschwankungen eingesetzt werden, können mit einem Heizelement als Kondenwasserschutz ausgestattet werden. Die einphasige Versorgung erfolgt über eine Zusatzklemmenleiste, die sich im Klemmenkasten befindet.

M19 - RECHAUFFEURS ANTICONDENSATION

Les moteurs fonctionnant dans des milieux très humides et/ou en présence de fortes plages thermiques peuvent être équipés d'une résistance anticondensation. L'alimentation monophasée est prévue par l'intermédiaire d'une boîte à bornes auxiliaire située dans la boîte principale.

H1

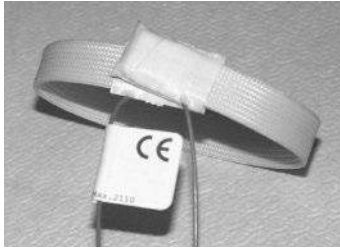

	H1 1~ 230V ± 10% P [W]
BN 56 ... BN 80	10
BN 90 ... BN 160MR	25
BN 160M ... BN 180M	50
BN 180L ... BN 200L	65



Durante il funzionamento del motore la resistenza anticondensa non deve mai essere alimentata.



Always remove power supply to the anti-condensate heater before operating the motor.



Während des Motorbetriebs darf die Wicklungsheizung nie gespeist werden.



Durant le fonctionnement du moteur, la résistance anticondensation ne doit jamais être alimentée.

M20 - TROPICALIZZAZIONE

M20 - TROPICALIZATION

M20 - TROPENSCHUTZ

M20 - TROPICALISATION

TP

Su richiesta, mediante la specifica dell'opzione TP, gli avvolgimenti del motore ottengono una protezione aggiuntiva che li rende idonei al funzionamento in condizioni di elevata temperatura e umidità.

When option TP is specified, motor windings receive additional protection for operation in high humidity and temperature conditions.

Wird die Option TP bestellt, wird die Motorwicklung mit einem zusätzlichen Schutz ausgestattet, der ihren Einsatz unter hohen Temperaturen und starker Feuchtigkeit ermöglicht.

Sur demande, en spécifiant l'option TP, les bobinages du moteur obtiennent une protection supplémentaire qui les rend apte au fonctionnement dans des conditions de température et d'humidité élevées.

M21 - ESECUZIONI ALBERO

M21 - ROTOR SHAFT CONFIGURATIONS

M21 - OPTIONEN DER ROTORWELLE

M21 - EXECUTIONS ARBRE ROTOR

PS

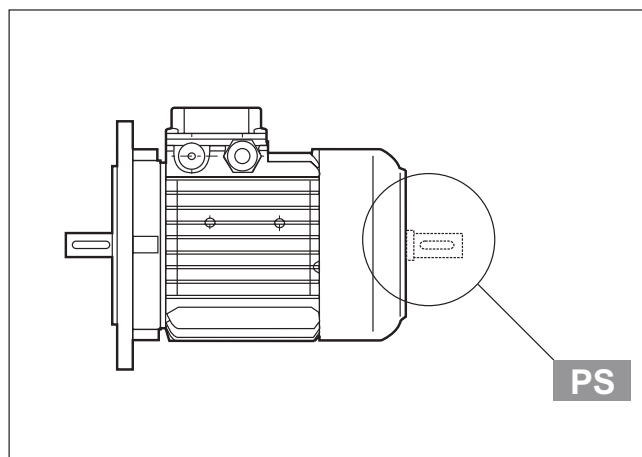

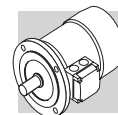

Seconda estremità d'albero

L'opzione esclude le varianti RC, TC, U1, U2, EN1, EN2, EN3 – non applicabile ai motori con freno tipo BA.

Le dimensioni sono reperibili nelle tavole dimensionali dei motori.

Second shaft extension

This option is not compatible with variants RC, TC, U1, U2, EN1, EN2, EN3 – and is not feasible on motors equipped with BA brake.

For shaft dimensions please see motor dimensions tables.

Zweites Wellenende

Diese Option schließt die Optionen RC, TC, U1, U2, EN1, EN2, EN3 aus – sie kann nicht außerdem nicht an Motoren, die mit einer Bremse vom Typ BA ausgestattet sind, angebaut werden. Die entsprechenden Maße können den Maßtabellen der Motoren entnommen werden.

Arbre à double extrémité

L'option exclut les variantes RC, TC, U1, U2, EN1, EN2, EN3 – non applicables aux moteurs avec frein type BA.

Les dimensions figurent sur les planches de dimensions des moteurs.

M22 - EQUILBRATURA ROTORE

I motori sono equilibrati dinamicamente con mezza linguetta e rientrano nel grado di vibrazione **N**, secondo la Norma CEI EN 60034-14.

M22 - ROTOR BALANCING

*Motors are dynamically balanced with a half key and fall within vibration class **N** in accordance with standard CEI EN 60034-14.*

M22 - ROTORAUSWUCHTUNG

Die Motoren werden dynamisch durch das Einsetzen eines halben Federkeils ausgewuchtet und fallen der Norm CEI EN 60034-14 gemäß unter die Einstufung **N** des Schwingungsgrads.

M22 - EQUILIBRAGE DU ROTOR

*Les moteurs sont équilibrés du point de vue dynamique avec une demi-clavette et rentrent dans le degré de vibration **N**, selon la norme CEI EN 60034-14.*

RV

Per esigenze di particolare silenziosità è disponibile l'esecuzione opzionale **RV** che garantisce vibrazioni ridotte, secondo il grado **R**.

La tabella sottostante riporta i valori della velocità efficace di vibrazione per equilibratura normale (N) e in grado R.

*Where low noise is a priority requirement, the option **RV** ensures reduced vibration in accordance with vibration class **R**.*

The table below reports effective velocity of vibration for normal (N) and R grade balancing.

Sollte eine besondere Laufruhe gefordert werden, steht als Option **RV** eine Ausführung mit reduziertem Schwingverhalten nach Grad **R**, zur Verfügung.

Die folgende Tabelle gibt die Werte der effektive Schwingungen für das normale Auswuchten (N) und im Grad R an.

*En cas d'exigence particulière de faible niveau de bruit, l'exécution **RV** est disponible en option, elle garantit des vibrations réduites, de degré **R**.*

Le tableau ci-dessous indique les valeurs de la vitesse efficace de vibration pour un équilibrage normal (N) et en degré R.

(26)

Grado di vibrazione Vibration class Schwingungsklasse Degré de vibration	Velocità di rotazione Synchronous speed Drehungsgeschwindigkeit Vitesse de rotation n [min ⁻¹]	Limiti della velocità di vibrazione Limits of the vibration velocity Grenzen der Schwingungsgeschwindigkeit Limites de la vitesse de vibration (mm/s)	
		63 < H ≤ 132	132 < H ≤ 200
N	600 < n < 3600	1.8	2.8
R	600 < n < 1800	0.71	1.12
	1800 < n < 3600	1.12	1.8

I valori si riferiscono a misure con motore liberatamente sospeso e funzionamento a vuoto; tolleranza ±10%.

Values are obtained from measurements on freely suspended motor during no-load operation; tolerance ± 10%.

Diese Werte beziehen sich auf einem frei hängenden und sich im Leerbetrieb befindlichen Motor; Toleranz ± 10%.

Les valeurs se réfèrent à des mesures avec moteur librement suspendu et fonctionnement à vide, tolérance ± 10%.

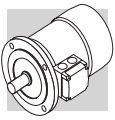

**M23 - PROTEZIONI
MECCANICHE
ESTERNE**

**M23 - EXTERNAL
MECHANICAL
PROTECTIONS**

**M23 - MECHANISCHE
SCHUTZVORRICHTUNGEN**

**M23 - PROTECTIONS
MECANIQUES
EXTERIEURES**

RC

Il dispositivo parapigioggia, che è raccomandato quando il motore è montato verticalmente con l'albero verso il basso, serve a proteggere il motore stesso dall'ingresso di corpi solidi e dallo stillicidio. Le dimensioni aggiuntive sono indicate nella tabella (27).

Il tettuccio esclude le varianti PS, EN1, EN2, EN3 e non è applicabile ai motori con freno tipo BA.

The rain canopy protects the motor from dripping and avoids the ingress of solid matter. It is recommended when motor is installed in a vertical position with the shaft pointing downwards.

Relevant dimensions are indicated in the table (27).

The rain canopy is not compatible with variants PS, EN1, EN2, EN3 and will not fit motors equipped with a BA brake.

Ein Regenschutzdach, dessen Montage empfohlen wird, wenn der Motor senkrecht mit einer nach unten gerichteten Welle montiert wird. Es dient dem Schutz des Motors vor dem Eindringen von festen Fremdkörpern und Tropfwasser. Die Dimensionen werden in der Tabelle (27) angegeben. Das Schutzdach schließt die Möglichkeit der Optionen PS, EN1, EN2, EN3 aus und kann bei Bremsmotoren vom Typ BN_BA nicht montiert werden.

Le capot de protection antipluie est recommandé lorsque le moteur est monté verticalement avec l'arbre vers le bas, il sert à protéger le moteur contre l'introduction de corps solides et le suintement. Les dimensions à ajouter sont indiquées dans le tableau (27).

Le capot antipluie exclue les variantes PS, EN1, EN2, EN3 et n'est pas applicable aux moteurs avec frein type BA.

(27)

	AQ	Δ V
BN 63	118	24
BN 71	134	27
BN 80	152	25
BN 90	168	30
BN 100	190	28
BN 112	211	32
BN 132 ... BN 160MR	254	32
BN 160M ... BN 180M	302	36
BN 180L ... BN 200L	340	36

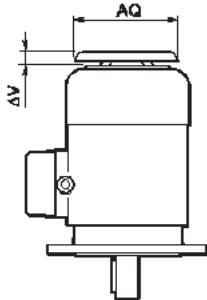

TC

La variante del tettuccio tipo TC è da specificare quando il motore è installato in ambienti dell'industria tessile, dove sono presenti filamenti che potrebbero ostruire la griglia del copriventola, impedendo il regolare flusso dell'aria di raffreddamento.

L'opzione esclude le varianti EN1, EN2, EN3 e non è applicabile ai motori con freno tipo BA.

L'ingombro complessivo è lo stesso del tettuccio tipo RC.

Option TC is a rain canopy variant for textile industry environments, where lint may obstruct the fan grid and prevent a regular flow of cooling air.

This option is not compatible with variants EN1, EN2, EN3 and will not fit motors equipped with a BA brake.

Overall dimensions are the same as rain canopy type RC.

Bei dieser Option handelt es sich um ein Schutzdach mit einem Textilnetz, dessen Einsatz empfohlen wird wenn der Motor in Bereichen der Textilindustrie installiert wird, in denen Stofffusseln das Lüfterradgitter verstopfen und so einen ausreichenden Kühlluftfluss verhindern könnten. Diese Option schließt die Möglichkeit der Optionen EN1, EN2, EN3 aus und kann bei Bremsmotoren vom Typ BN_BA nicht montiert werden.

Die Gesamtmaße entsprechen denen des Schutzdachs vom Typ RC.

La variante du capot type TC est à spécifier lorsque le moteur est installé dans des sites de l'industrie textile, où sont présents des filaments qui pourraient obstruer la grille du cache-ventilateur et empêcher le flux régulier de l'air de refroidissement. L'option exclue les variantes EN1, EN2, EN3 et n'est pas applicable aux moteurs avec frein type BA.

L'encombrement total est identique à celui du capot type RC.

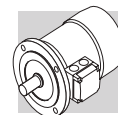

M24 - MOTORI ASINCRONI AUTOFRENANTI

Funzionamento

L'esecuzione autofrenante prevede l'impiego di freni a pressione di molle alimentati in c.c. (tipo FD) o in c.a. (tipo FA, BA).

Tutti i freni funzionano secondo il principio di sicurezza, ossia intervengono in seguito alla pressione esercitata dalle molle, in mancanza di alimentazione.

M24 - ASYNCHRONOUS BRAKE MOTORS

Operation

Versions with incorporated brake use spring-applied DC (FD option) or AC (FA, BA options) brakes.

All brakes are designed to provide fail-safe operation, meaning that they are applied by spring-action in the event of power failure.

M24 - DREHSTROMBREMS- MOTOREN

Betriebsweise

Die selbstbremsende Ausführung der Motoren sieht den Einsatz von Federdruckbremsen vor, die mit Gleichstrom (Typ FD) oder mit Wechselstrom (Typ FA, BA) gespeist werden. Alle Bremsen arbeiten gemäß dem Sicherheitsprinzip, d.h. sie greifen, im Fall eines Stromausfalls in Folge eines auf die Feder ausgeübten Drucks ein.

M24 - MOTEURS FREIN ASYNCHRONES

Fonctionnement

L'exécution avec frein prévoit l'utilisation de freins à pression de ressorts alimentés en c.c. (type FD) ou en c.a. (type FA, BA). Tous les freins fonctionnent selon le principe de sécurité, c'est-à-dire qu'ils interviennent suite à la pression exercée par les ressorts, en cas de coupure d'alimentation.

(28)

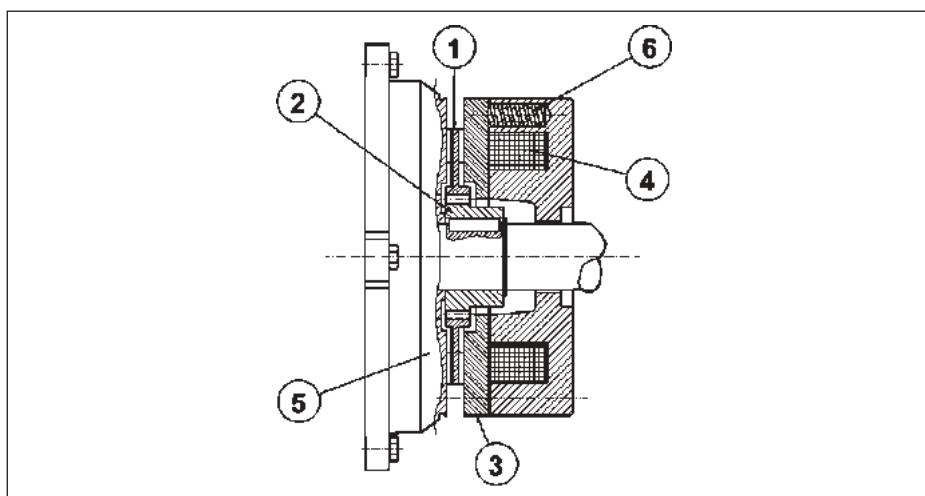

Legenda:

- ① disco
- ② mozzo
- ③ áncora mobile
- ④ bobina
- ⑤ scudo NDE motore
- ⑥ molle

Key:

- ① brake disc
- ② disc carrier
- ③ pressure plate
- ④ brake coil
- ⑤ motor NDE shield
- ⑥ brake springs

Zeichenerklärung:

- ① Brems scheibe
- ② Nabe
- ③ Beweglicher Anker
- ④ Ringspule
- ⑤ Motorschild
- ⑥ Schußfedern

Légende:

- ① disque
- ② moyeu d'entraînement
- ③ disque de freinage
- ④ flasque-frein
- ⑤ flasque arrière
- ⑥ ressort de frein

In mancanza di tensione, l'ancora mobile spinta dalle molle di pressione blocca il disco freno tra la superficie dell'ancora stessa e lo scudo motore impedendo la rotazione dell'albero. Quando la bobina viene eccitata, l'attrazione magnetica esercitata sull'ancora mobile vince la reazione elastica delle molle e libera il disco freno, e conseguentemente l'albero motore con esso solidale.

When voltage is interrupted, pressure springs push the armature plate against the brake disc. The disc becomes trapped between the armature plate and motor shield and stops the shaft from rotation. When the coil is energized, a magnetic field strong enough to overcome spring action attracts the armature plate, so that the brake disc – which is integral with the motor shaft – is released.

Wenn die Spannungsversorgung abfällt, sorgt der bewegliche, von den Druckfedern geschobene Anker für die Blockierung der Bremsscheibe zwischen der Ankerfläche und dem Motorschild und blockiert damit den Rotor. Wird die Spule erregt, kommt es durch den magnetischen auf den beweglichen Anker wirkenden Anzug zur Überwindung der elastischen Federkraft und zum Lösen der Bremsscheibe, wodurch der rotor wieder freigegeben wird.

En cas de coupure de courant, l'armature mobile, poussée par les ressorts, bloque le disque de frein entre la surface de l'armature et le bouclier moteur en empêchant la rotation de l'arbre. Lorsque la bobine est excitée, l'attraction magnétique exercée sur l'armature mobile annule la réaction élastique des ressorts et libère le disque de frein, et par conséquent l'arbre moteur, qui est solidaire.

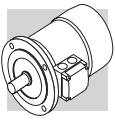

Caratteristiche generali:

- Coppie frenanti elevate (generalmente $M_b \cong 2 M_n$) e regolabili
- Disco freno con anima in acciaio a doppia guarnizione d'attrito (materiale a bassa usura, senza amianto)
- Cava esagonale sull'albero motore, lato ventola (N.D.E.), per rotazione manuale (non prevista quando sono presenti le opzioni PS, RC, TC, U1, U2, EN1, EN2, EN3)
- Sblocco meccanico manuale (opzioni **R** e **RM** per BN_FD, BN_FA).
- Trattamento anticorrosivo di tutte la superfici del freno
- Isolamento in classe F

Most significant features:

- *High braking torques (normally $M_b \cong 2 M_n$) braking torque adjustment*
- *Steel brake disc with double friction lining (low-wear, asbestos-free lining)*
- *Hexagonal seat on motor shaft fan end (N.D.E.) for manual rotation (not compatible with options PS, RC, TC, U1, U2, EN1, EN2, EN3)*
- *Manual release lever (options **R** and **RM** for BN_FD, BN_FA).*
- *Corrosion-proof treatment on all brake surfaces*
- *Insulation class F*

Allgemeine Eigenschaften:

- Hohe und regulierbare Bremsmomente (allgemein $M_b \cong 2 M_n$).
- Brems Scheibe mit Stahlkern und doppeltem Bremsbelag (Material mit geringem Verschleiß, asbestfrei).
- Sechskant hinten an der Motorwelle, auf Lüfterradseite (N.D.E.), für eine manuelle Drehung des Rotors mit einem Inbusschlüssel. (nicht lieferbar, wenn die Optionen PS, RC, TC, U1, U2, EN1, EN2, EN3) bestellt wurden.
- Manuell zu betätigende, mechanische Bremslüftvorrichtung (Optionen **R** und **RM** für BN_FD, BN_FA).
- Korrosionsschutzbehandlung an allen Flächen der Bremse.
- Isolierung in Klasse F.

Caractéristiques générales:

- *Couples de freinage élevés (généralement $M_b \cong 2 M_n$) et réglables.*
- *Disque de frein avec structure en acier à double garniture de frottement (matière à faible usure, sans amiante).*
- *Empreinte hexagonale sur l'arbre moteur, côté ventilateur (N.D.E.), pour la rotation manuelle (non prévue en cas de présence des options PS, RC, TC, U1, U2, EN1, EN2, EN3).*
- *Débloccage mécanique manuel (options **R** et **RM** pour BN_FD, BN_FA).*
- *Traitement anticorrosion sur toute la surface du frein.*
- *Isolation en classe F.*

M24.1 - LEVA SBLOCCO FRENO

I freni a pressione di molle tipo **FD** e **FA** possono essere dotati opzionalmente di dispositivi per lo sblocco manuale del freno, normalmente utilizzati per condurre interventi di manutenzione sulle parti di macchina, o dell'impianto, comandate dal motore.

M24.1 - BRAKE RELEASE SYSTEMS

*Spring-applied brakes type **FD** and **FA** may be equipped with optional manual release devices. These are typically used for manually releasing the brake before servicing any machine or plant parts operated by the motor.*

M24.1 - BREMSLÜFTHEBEL

Die Federdruckbremsen vom Typ **FD** und **FA** können Optional mit Bremslüfthebeln geliefert werden, die ein manuelles Lüften der Bremse ermöglichen. Diese Lüftungseinrichtungen können bei Instandhaltungsarbeiten an vom Motor betriebenen Maschinen- oder Anlagenteilen verwendet werden.

M24.1 - SYSTEMES DE DEBLOCCAGE FREIN

*Les freins à pression de ressorts type **FD** et **FA** peuvent, en option, être dotés de dispositifs de déblocage manuel du frein, normalement utilisés pour effectuer des interventions d'entretien sur les composants de la machine, ou de l'installation commandée par le moteur.*

R

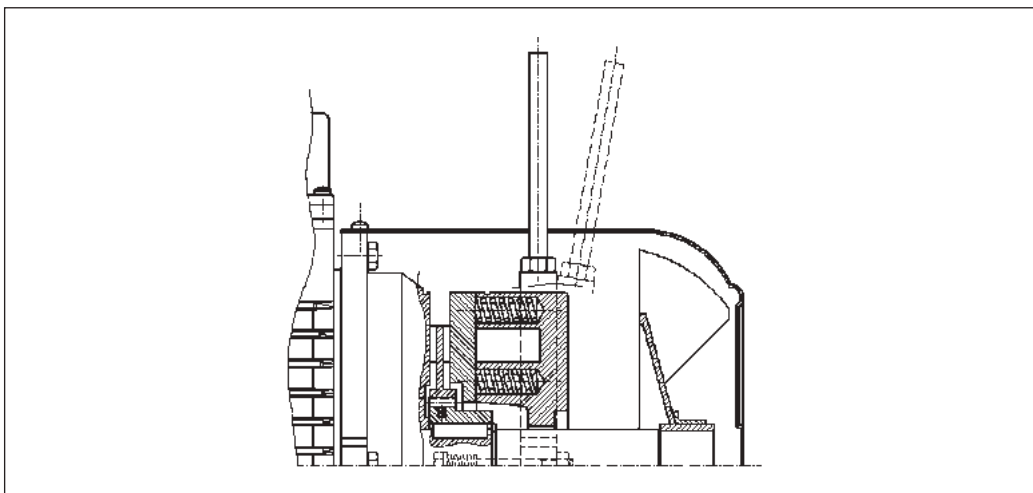

La leva di sblocco è dotata di ritorno automatico, tramite dispositivo a molla.

A return spring brings the release lever back in the original position.

Bremslüfthebel mit automatischer Rückstellung durch Federkraft.

Le levier de déblocage est doté de retour automatique, au moyen d'un dispositif à ressort.

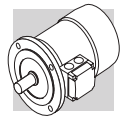

RM

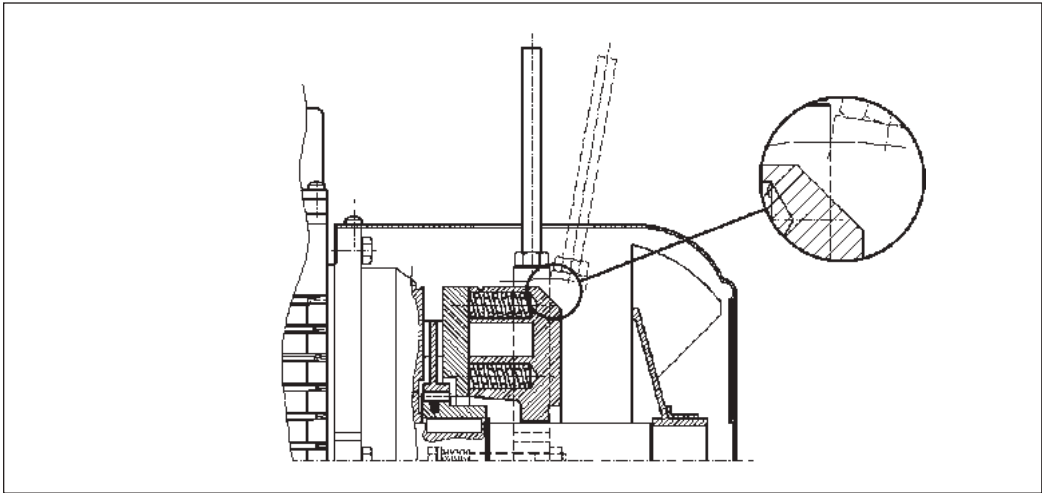

La leva di sblocco può essere temporaneamente bloccata in posizione di rilascio del freno, avvitando la stessa fino ad impegnarne l'estremità in un risalto del corpo del freno. La disponibilità dei sistemi di sblocco freno è diversa per i vari tipi di motore, ed è descritta dalla tabella seguente:

The release lever may be locked in the "release" position by tightening the lever until lever end becomes engaged with a brake housing projection. There are different brake release systems available for the various types of motors as indicated in the table below:

Der Bremslüfthebel kann zeitweise in der Bremslüftposition arretiert werden, indem man ihn so lange einschraubt, bis die Bremse arretiert ist. Für die unterschiedlichen Motortypen sind ebenso verschiedene Bremslüftsysteme verfügbar, die Sie der folgenden Tabelle entnehmen können:

Le levier de déblocage peut être temporairement bloqué en position de déblocage du frein en le vissant jusqu'à engager l'extrémité dans une saillie du corps du frein. La disponibilité des systèmes de déblocage du frein est différente en fonction des types de moteur et figure dans le tableau suivant :

(29)

	R	RM
BN_FD	$63 \leq H \leq 200$	2p 63A2 $\leq H \leq 132$ M2 4p 63A4 $\leq H \leq 132$ MA4 6p 63A6 $\leq H \leq 132$ MA6
BN_FA	$63 \leq H \leq 132$	⊖
BN_BA		

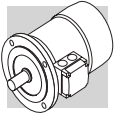

Orientamento della leva di sblocco

Per entrambe le opzioni **R** e **RM**, la leva di sblocco del freno viene collocata, se non diversamente specificato, con orientamento di 90° in senso orario, rispetto alla posizione della morsettiere - riferimento [AB] nel disegno sottostante. Orientamenti alternativi, tipo [AA], [AC] e [AD] possono essere richiesti citandone la relativa specifica:

Release lever orientation

*Unless otherwise specified, the release lever is located 90° away from the terminal box – identified by letters [AB] in the diagram below – in a clockwise direction on both options **R** and **RM**. Alternative lever positions [AA], [AC] and [AD] are also possible when the corresponding option is specified:*

Ausrichtung des Bremslüfthebels

Bei beiden Optionen, **R** und **RM**, wird der Bremslüfthebel, falls nicht anderweitig festgelegt, um 90° im Uhrzeigersinn zur Position des Klemmenkastens montiert (Position [AB] in der nachfolgenden Zeichnung). Andere Positionen: **AA** (0° zum Klemmenkasten), **AC** (180° zum Klemmenkasten) oder **AD** (270° zum Klemmenkasten, im Uhrzeigersinn vom Lüfter aus gesehen) können unter Angabe der entsprechenden Spezifikation bestellt werden:

Orientation du levier de déblocage

*Pour les deux options **R** et **RM**, le levier de déblocage du frein est positionné, sauf spécification contraire, avec une orientation de 90° dans le sens des aiguilles d'une montre par rapport à la position de la boîte à bornes - référence [AB] sur le dessin ci-dessous. Des orientations différentes, type [AA], [AC] et [AD] peuvent être demandées à condition de préciser la position correspondante :*

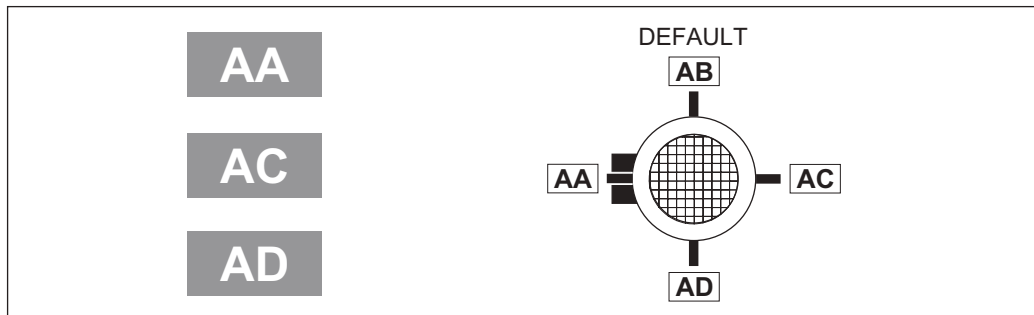

M24.2 - ALIMENTAZIONE SEPARATA DEL FRENO

...SA

La bobina del freno è alimentata da linea separata e indipendente dall'alimentazione del motore. Il valore di tensione alla bobina deve essere specificato, es. 230SA. L'opzione è applicabile ai motori con freno tipo FD, FA e BA.

M24.2 - SEPARATE BRAKE SUPPLY

The brake coil is directly fed through an independent line, separately from the motor. In this case the rated voltage for the coil must be specified, e.g. 230SA. The option is applicable to all motors with brake type FD, FA and BA.

M24.2 - BREMSE MIT SEPARATER SPANNUNGSVERSORGUNG

Die Bremsspule wird, unabhängig vom Motor, durch einen separaten Anschluss gespeist. In diesem Fall muss Betriebsspannung fuer die spule spezifiziert werden, z.b. 230SA. Die Option ist verfuegbar für alle Motoren mit Bremstyp FD, FA und BA.

M24.2 - ALIMENTATION FREIN SEPARÉE

La bobine du frein est alimentée par une ligne séparée et indépendante de l'alimentation du moteur. La valeur de tension à la bobine doit être spécifiée, ex. 230SA. L'option est applicable aux moteurs avec frein type FD, FA et BA.

...SD

La bobina del freno tipo FD è alimentata direttamente con corrente continua e l'alimentatore NON è fornito. Il valore di tensione alla bobina deve essere specificato, es. 24SD.

The brake coil is directly fed with DC current and the rectifier is out of the scope for supply. The rated voltage for the coil must be specified, e.g. 24SD.

Die Bremsspule wird direkt mit Gleichspannung gespeist. Der Gleichrichter ist nicht im Lieferumfang enthalten. Die Betriebsspannung für die Spule muss spezifiziert werden, z.b. 24SD.

La bobine du frein type FD est alimentée directement avec courant continu et l'alimentateur n'est pas fourni. La valeur de tension à la bobine doit être spécifiée, es. 24SD.

M24.3 - FREQUENZA MASSIMA D'AVVIAMENTO

Nelle tabelle dei dati tecnici, per ogni tipo di freno, è indicata la massima frequenza di inserzione a vuoto Z_0 , con intermittenza $I = 50\%$. Questo valore definisce il nume-

M24.3 - MAXIMUM STARTS PER HOUR

For all types of Brakes the rating charts reports the maximum number of starts per hour under no-load conditions Z_0 with cyclic duration factor $I = 50\%$. This parameter gives the num-

M24.3 - MAX. SCHALTHÄUFIGKEIT

In den Tabellen, in denen die technischen Daten enthalten sind, wird für jeden Bremstyp die maximal Schalthäufigkeit im Leerbetrieb Z_0 mit einer Einschaltdauer $I = 50\%$ angege-

M24.3 - FREQUENCE MAXIMUM DE DEMARRAGE

Les tableaux des caractéristiques techniques indiquent, pour chaque type de frein, la fréquence maximum d'enclenchement à vide Z_0 , avec intermittenza $I = 50\%$. Cette valeur dé-

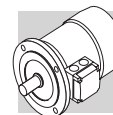

ro di avviamenti orari a vuoto che il motore può sopportare senza superare la temperatura ammessa dalla classe di isolamento F.

Nel caso pratico di motore accoppiato ad un carico esterno con potenza assorbita P_r , massa inerziale J_c e coppia resistente media durante l'avviamento M_L , il numero di avviamenti ammissibile si può calcolare con la seguente formula:

ber of starts per hour under no-load conditions a motor can withstand without exceeding the temperature limit permitted for insulation class F.

Assuming an application involving an overhung load applied to the motor with absorbed power P_r , inertial mass J_c and starting mean load torque M_L , the number of starts allowed is calculated by the following formula:

ben. Dieser Wert legt die Anzahl der Schaltungen im Leerbetrieb pro Stunde fest, denen der Motor standhalten kann, ohne dabei die von der Isolierstoffklasse F zulässige Temperatur zu überschreiten. Im praktischen Fall eines an eine externe Last gekoppelten Motors mit einer Leistungsaufnahme P_r , Trägheitsmasse J_c und einem durchschnittlichen Gegendrehmoment während des Anlaufs M_L , kann die Anzahl der zulässigen Schaltungen anhand der nachstehenden Formel berechnet werden:

finit le nombre de démarrages horaires à vide que le moteur peut supporter sans dépasser la température admise par la classe d'isolation F.

Dans le cas pratique d'un moteur accouplé à une charge extérieure avec puissance absorbée P_r , masse inertielle J_c et couple résistant moyen durant le démarrage M_L , il est possible de calculer le nombre de démarrages admissibles avec la formule suivante :

$$Z = \frac{Z_0 \cdot K_c \cdot K_d}{K_J}$$

dove:

$$K_J = \frac{J_m + J_c}{J_m} = \text{fattore di inerzia}$$

$$K_c = \frac{M_a - M_L}{M_a} = \text{fattore di coppia}$$

K_d = fattore di carico vedi tabella:

where

$$K_J = \frac{J_m + J_c}{J_m} = \text{inertia factor}$$

$$K_c = \frac{M_a - M_L}{M_a} = \text{torque factor}$$

K_d = load factor see table:

wobei gilt:

$$K_J = \frac{J_m + J_c}{J_m} = \text{Trägheitsfaktor}$$

$$K_c = \frac{M_a - M_L}{M_a} = \text{Drehmomentsfaktor}$$

K_d = Lastfaktor siehe Tabelle:

où

$$K_J = \frac{J_m + J_c}{J_m} = \text{facteur d'inertie}$$

$$K_c = \frac{M_a - M_L}{M_a} = \text{facteur de couple}$$

K_d = facteur de charge voir tableau

(30)

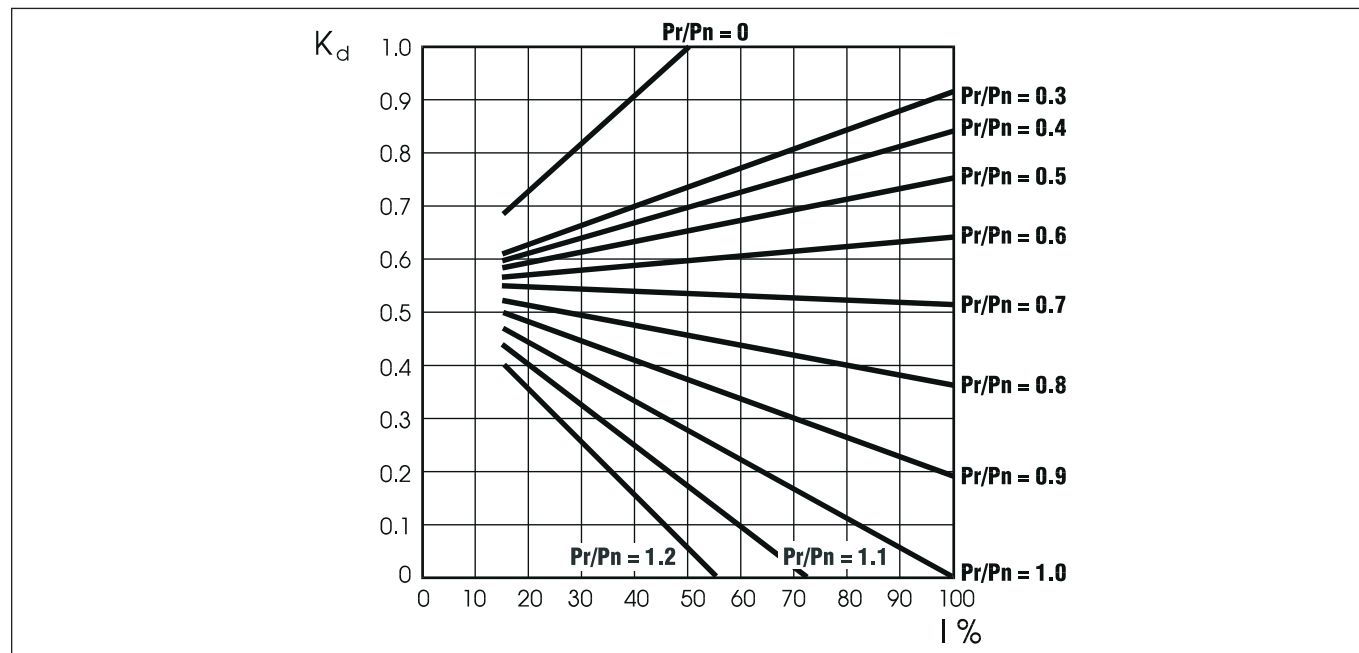

Con il numero di avviamenti così ottenuto si dovrà in seguito verificare che il massimo lavoro di frenatura sia compatibile con la capacità termica del freno W_{max} .

The resulting number of starts must be double-checked against maximum braking effort, which must be compatible with brake thermal capacity W_{max} .

Auf Grundlage der berechneten Anzahl der Schaltungen muss man prüfen, ob die maximale Bremsleistung mit der angegebenen thermischen Leistung der Bremse W_{max} übereinstimmt.

Avec le nombre de démarrages ainsi obtenu, il est ensuite nécessaire de vérifier que l'action maximum de freinage est compatible avec la capacité thermique du frein W_{max} .

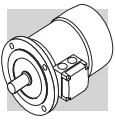

M24.4 - AVVIAMENTO PROGRESSIVO

M24.4 - SOFT-START / STOP

M24.4 - SANFTANLAUF / STOP

M24.4 - DEMARRAGE/ARRET PROGRESSIF

F1

Per applicazioni che richiedono progressività nelle fasi di avvio e di arresto è disponibile un volano – opzione **F1** – la cui inerzia aggiuntiva assorbe energia cinetica durante l'avviamento e la restituisce in frenatura, rendendo i transitori più progressivi e gradualmente.

Il volano è disponibile per i motori autofrenanti del tipo BN_FD, con caratteristiche specifiche dettagliate nella tabella che segue:

*An optional flywheel – option **F1** – is available for applications requiring soft starting or stopping. The flywheel's added inertia uses up kinetic energy during starting and returns it back during braking, thus catering for more progressive and gradual shock loads.*

The optional flywheel is available for brake motors type BN_FD, with specific characteristics as detailed in the table below:

Für Anwendungen, bei denen einer sanfte Anlauf- und Stop erforderlich ist, steht als – Option **F1** – ein Schwungrad zur Verfügung, dessen zusätzliches Trägheitsmoment während der Anlaufphase kinetische Energie aufnimmt, die in der Abbremsphase wieder abgegeben wird. Dadurch erfolgen die Übergangsphasen progressiver und sanfter. Das Schwungrad ist für die Bremsmotoren vom Typ BN_FD in den nachstehend aufgeführten spezifischen Details verfügbar:

*Pour les applications nécessitant une progressivité au cours des phases de démarrage et d'arrêt, un volant – option **F1** – est disponible ; son inertie supplémentaire absorbe l'énergie cinétique durant le démarrage et la restitue au moment du freinage, rendant ainsi les phases transitoires plus progressives et graduelles: Le volant est disponible pour les moteurs frein du type BN_FD, ses caractéristiques spécifiques détaillées sont indiquées dans le tableau suivant :*

(31)

Volano per avviamento progressivo / Flywheel for soft starting / Schwungräder für Sanftanlauf Volant pour démarrage/arrêt progressif		
BN_FD	Peso del volano Flywheel weight Gewicht Schwungrad Poids du volant [Kg]	Inerzia volano Flywheel inertia Trägheitsmoment des Schwungrad Inertie du volant J _v [Kg m ²]
BN 63	0.69	0.00063
BN 71	1.13	0.00135
BN 80	1.67	0.00270
BN 90	2.51	0.00530
BN 100	3.48	0.00840
BN 112	4.82	0.01483
BN 132	6.19	0.02580

Per le esigenze di particolari applicazioni, ad es. traslazioni, che richiedano regolazioni micrometriche della coppia frenante è disponibile una serie di motori autofrenanti, denominata BN_FM, dettagliata nel catalogo cod. 1134 R1, sviluppato per le motorizzazioni dei carriponte. Consultare per questo il Servizio Tecnico Bonfiglioli.

For special applications that require a fine adjustment of braking torque, as is the case with track drives, a specific brake motor type BN_FM is available. This type of product has been developed for bridge crane drives and is described in detail in catalogue no. 1134 R1. Please contact Bonfiglioli Engineering for more details.

Für besondere Anwendungen, z.B. Transfers, die fein abgestufte Einstellungen des Bremsmoments erfordern, ist eine Reihe an Bremsmotoren verfügbar (BN_FM) und die detailliert im Katalog Art.-Nr. 1134 R1 beschrieben werden. Dieser Katalog ist für die Antriebe von Laufkränen entwickelt wurde. Wenden Sie sich diesbezüglich bitte an unseren Technischen Kundendienst.

En cas d'exigences d'applications particulières, par ex. translations, qui nécessitent des réglages micrométriques du couple de freinage, une série de moteurs frein est disponible, dénommée BN_FM, détaillée dans le catalogue réf. 1134 R1, conçue pour les motorisations des ponts roulants. Dans ce cas, consulter le Service Bonfiglioli.

M24.5 - FILTRO CAPACITIVO

M24.5 - CAPACITIVE FILTER

M24.5 - KAPAZITIVER FILTER

M24.5 - FILTRE CAPACITIF

CF

Per i soli motori autofrenanti in corrente continua, tipo BN_FD, è disponibile in opzione il filtro capacitivo. Se corredati dell'opportuno filtro capacitivo a monte del raddrizzatore (opzione CF) i motori rientrano nei limiti di emissione previsti dalla Norma EN 50081-1 "Compatibilità elettromagnetica - Norma Generica sull'emissione – Parte 1: Ambienti residenziali, commerciali e dell'industria leggera".

An optional capacitive filter is available for DC brake motors type BN_FD only. When the suitable capacitive filter is installed upstream of the rectifier (option CF), motors comply with the emission limits required by standard EN 50081-1 "Electromagnetic Compatibility – Generic Emission Standard – Part 1: Residential, commercial and light industrial environment".

Nur bei den Bremsmotoren mit Gleichstrombremse vom Typ BN_FD, ist die Option eines kapazitiven Filters vorgesehen. Wird dieser Filter vor dem Gleichrichter (Option CF) installiert, fallen die Motoren in die von der Norm EN 50081-1 "Elektromagnetische Kompatibilität – Allgemeine Norm zur Emission – Teil 1: Wohngebiete, Handels- und Leichtindusztrienzonen" vorgegebenen Emissionsgrenzen.

Un filtre capacitif en option est disponible uniquement pour les moteurs frein en courant continu type BN_FD. S'ils sont équipés du filtre capacitif approprié en amont du redresseur (option CF), les moteurs rentrent dans les limites d'émission prévues par la Norme EN 50081-1 "Compatibilité électromagnétique - Norme Générique sur l'émission – Partie 1: Milieux résidentiels, commerciaux et de l'industrie légère".

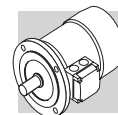

**M25 - MOTORI
AUTOFRENANTI
IN C.C., TIPO BN_FD**

**M25 - DC BRAKE MOTORS
TYPE BN_FD**

**M25 - WECHSELSTROMBREMS-
MOTOREN MIT G.S.-
BREMSE TYP BN_FD**

**M25 - MOTEURS FREIN EN
C.C., TYPE BN_FD**

- Grandezze: BN 63 ... BN200L

- Frame sizes: BN 63 ... BN200L

- Baugrößen: BN 63 ... BN 200L

- Tailles : BN 63 ... BN200L

(32)

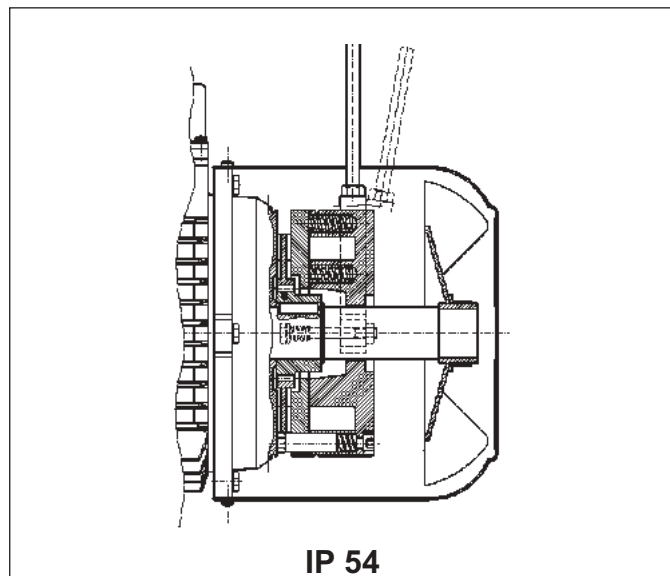

IP 54

Freno elettromagnetico con bobina toroidale in corrente continua fissato con viti allo scudo motore; le molle di precarico realizzano il posizionamento assiale del corpo magnete. Il disco freno è scorrevole sul mozzo trascinato in acciaio calettato sull'albero e previsto di molla antivibrazione. I motori sono forniti con freno tarato in fabbrica al valore di coppia riportato nelle tabelle dati tecnici; la coppia frenante può essere regolata modificando il tipo e/o il numero delle molle. A richiesta, i motori possono essere previsti di leva per lo sblocco manuale con ritorno automatico (R) o con mantenimento della posizione di rilascio freno (RM); per la posizione angolare della leva di sblocco vedi descrizione della relativa variante alla pag. 122. Il freno FD garantisce elevate prestazioni dinamiche e bassa rumorosità; le caratteristiche d'intervento del freno in corrente continua possono essere ottimizzate in funzione dell'applicazione, utilizzando i vari tipi di alimentatore disponibili e/o realizzando l'opportuno cablaggio.

Direct current toroidal-coil electromagnetic brake bolted onto motor shield. Preloading springs provide axial positioning of magnet body.

Brake disc slides axially on steel hub shrunk onto motor shaft with anti-vibration spring. Brake torque factory setting is indicated in the corresponding motor rating charts. Braking torque may be modified by changing the type and/or number of springs.

At request, motors may be equipped with manual release lever with automatic return (R) or system for holding brake in the released position (RM).

See variant at page 122 for available release lever locations.

FD brakes ensure excellent dynamic performance with low noise. DC brake operating characteristics may be optimized to meet application requirements by choosing from the various rectifier/power supply and wiring connection options available.

(33)

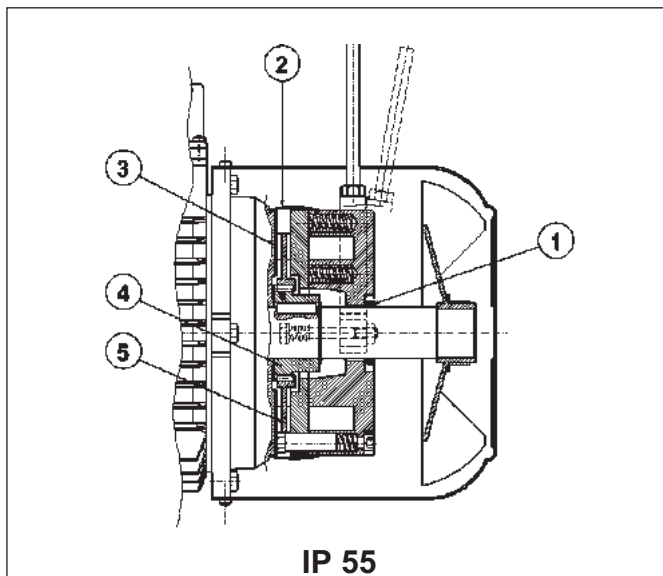

IP 55

Elektromagnetische Bremse mit Ringwicklungsspule für Gleichstromspannung, die mittels Schrauben am hinteren Motorschild befestigt ist. Die Federn sorgen für die axiale Ausrichtung des Magnetkörpers. Die Bremscheibe gleitet axial auf der Mitnehmernabe aus Stahl, die über eine Paßfeder mit der Motorwelle verbunden und mit einer Schwingungsdämpfung ausgestattet ist. Die Motoren werden vom Hersteller auf den in der Tabelle der technischen Daten angegebenen Bremsmoment eingestellt; das Bremsmoment kann durch das Ändern des Typs und/oder der Anzahl der Federn reguliert werden. Auf Anfrage können die Motoren mit einem Bremslüfthebel für die manuelle Lüftung der Bremse mit selbstständiger Rückstellung (R) ohne Arretierung oder mit arretierbarem Lüfthebel (RM) geliefert werden. Die Festlegung der Position des Bremslüfthebel in Abhängigkeit von der Klemmkastenlage erfolgt durch die Option auf Seite 122.

Die Bremse vom Typ FD garantiert hohe dynamische Leistungen und niedrige Laufgeräusche. Die Ansprechigenschaften der Bremse unter Gleichstrom können in Abhängigkeit zur jeweiligen Anwendung durch den Einsatz der verschiedenen verfügbaren Gleichrichter oder durch eine entsprechenden Anschluß der Bremse optimiert werden.

Frein électromagnétique avec bobine toroïdale en courant continu, fixé avec des vis au bouclier moteur ; les ressorts de précharge réalisent le positionnement axial de la bobine. Le disque frein coulisse de façon axiale sur le moyeu d'entraînement en acier calé sur l'arbre et doté de ressort antivibration. Les moteurs sont fournis avec frein pré réglé en usine à la valeur de couple indiquée dans les tableaux des caractéristiques techniques ; le couple de freinage peut être réglé en modifiant le type et/ou le nombre de ressorts. Sur demande, les moteurs peuvent être équipés de levier pour le déblocage manuel avec retour automatique (R) ou avec maintien de la position de déblocage frein (RM); pour la position angulaire du levier de déblocage, voir description de la variante correspondante à la page 122. Le frein FD garantit des performances dynamiques élevées et un faible niveau de bruit ; les caractéristiques d'intervention du frein en courant continu peuvent être optimisées en fonction de l'application en utilisant les différents types de dispositifs d'alimentation disponibles et/ou en réalisant un câblage approprié.

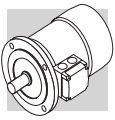

- Grado di protezione

L'esecuzione standard prevede il grado di protezione IP54. In opzione il motore autofrenante tipo FD viene fornito con grado di protezione **IP 55**, prevedendo le seguenti varianti costruttive:

- ① anello V-ring posizionato sull'albero motore N.D.E.
- ② fascia di protezione in gomma
- ③ anello in acciaio inox interposto tra scudo motore e disco freno
- ④ mozzo trascinatore in acciaio inox
- ⑤ disco freno in acciaio inox

- Degree of protection

Standard protection is IP54. Brake motor FD is also available in protection **IP 55**, which mandates the following variants:

- ① V-ring at N.D.E. of motor shaft
- ② dust and water-proof rubber boot
- ③ stainless steel ring placed between motor shield and brake disc
- ④ stainless steel hub
- ⑤ stainless steel brake disc

- Schutzart

Die Standardausführung ist Schutzart IP54 vor. Optional kann der Bremsmotor vom Typ FD in der Schutzart **IP 55** geliefert werden, wobei sind folgende Komponenten eingesetzt werden:

- ① V-Ring an der Motorwelle N.D.E.
- ② Schutzring aus Gummi
- ③ Ring aus rostfreiem Stahl zwischen Motorschild und Bremsscheibe
- ④ Mitnehmernabe aus rostfreiem Stahl
- ⑤ Bremsscheibe aus rostfreiem Stahl

- Degré de protection

L'exécution standard prévoit le degré de protection IP54. En option, le moteur frein type FD est fourni avec degré de protection IP 55, en prévoyant les variantes de construction suivantes :

- ① bague V-ring positionnées sur l'arbre moteur N.D.E.
- ② bande de protection en caoutchouc
- ③ bague en acier inox interposée entre le bouclier moteur et le disque de frein
- ④ moyeu d'entraînement en acier inox
- ⑤ disque frein en acier inox

- Alimentazione freno FD

L'alimentazione della bobina freno in c.c. è prevista per mezzo di opportuno raddrizzatore montato all'interno della scatola coprimorsetti e già cablato alla bobina del freno. Per motori a singola polarità è inoltre previsto di serie il collegamento del raddrizzatore alla morsettiera motore. Indipendentemente dalla frequenza di rete, la tensione standard di alimentazione del raddrizzatore V_B ha il valore indicato nella tabella qui di seguito:

- FD brake power supply

A rectifier accommodated inside the terminal box feeds the DC brake coil. Wiring-connection across rectifier and brake coil is performed at the factory. On all single-pole motors, rectifier is connected to the motor terminal board. Rectifier standard power supply voltage V_B is as indicated in the following table, regardless of mains frequency:

- Spannungsversorgung der Bremse FD

Die Versorgung der Gleichstrombremsspule erfolgt über einen Gleichrichter im Klemmenkasten der bei Lieferung, wenn nicht anders bestellt, bereits mit der Bremsspule verkabelt ist. Bei den einpoligen Motoren ist serienmäßig der Anschluss des Gleichrichters an die Motorspannung vorgesehen. Unabhängig von der Netzfrequenz erfolgt die Versorgung des Gleichrichters V_B über die in der nachstehenden Tabelle angegebenen Standardspannung:

- Alimentation frein FD

L'alimentation de la bobine de frein en c.c. est prévue au moyen d'un redresseur approprié monté à l'intérieur de la boîte à bornes et déjà câblé à la bobine de frein. De plus, pour les moteurs à simple polarité, le raccordement du redresseur au bornier moteur est prévu de série. Indépendamment de la fréquence du réseau, la tension standard d'alimentation du redresseur V_B correspond à la valeur indiquée dans le tableau ci-dessous :

(34)

2, 4, 6 P			1 speed	
	BN_FD		alimentazione freno da morsettiera brake connected to terminal board power supply Bremsversorgung über die Motorspannung Alimentation frein depuis boîte à bornes	alimentazione separata separate power supply Separate Versorgung Alimentation séparée
	$V_{mot} \pm 10\%$ 3 ~	$V_B \pm 10\%$ 1 ~		
BN 63...BN 132	230/400 V – 50 Hz	230 V	standard	specificare V_B SA o V_B SD specify V_B SA or V_B SD V_B SA oder V_B SD angeben spécifier V_B SA ou V_B SD
BN 160...BN 200	400/690 V – 50 Hz	400 V	standard	specificare V_B SA o V_B SD specify V_B SA or V_B SD V_B SA oder V_B SD angeben spécifier V_B SA ou V_B SD

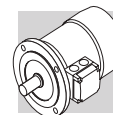

Per i motori a doppia polarità l'alimentazione standard del freno è da linea separata con tensione d'ingresso al raddrizzatore V_B come indicato in tabella:

Switch-pole motors feature a separate power supply line for the brake with rectifier input voltage V_B as indicated in the table:

Die polumschaltbaren Motoren müssen immer mit separater Bremsversorgungsspannung betrieben werden, deshalb erfolgt die Lieferung standardmäßig ohne Anschluß der Bremse an die Motorspannung, da diese mit einer am Eingang des Gleichrichters V_B anliegenden Spannung versorgt werden muß, entsprechend Werte in der nachstehenden Tabelle:

Pour les moteurs à double polarité, l'alimentation standard du frein dérive d'une ligne séparée avec tension d'entrée a redresseur V_B comme indiqué dans le tableau :

(35)

2/4, 2/6, 2/8, 2/12, 4/6, 4/8 P			2 speed	
	BN_FD		alimentazione freno da morsettiera <i>brake powered via terminal board</i> Bremsversorgung über die Motorspannung <i>Alimentation frein depuis boîte à bornes</i>	alimentazione separata <i>separate power supply</i> Separate Versorgung <i>Alimentation séparée</i>
	$V_{mot} \pm 10\%$ 3 ~	$V_B \pm 10\%$ 1 ~		
BN 63...BN 132	400 V – 50 Hz	230 V	●	specificare $V_B SA$ o $V_B SD$ <i>specify $V_B SA$ or $V_B SD$</i> $V_B SA$ oder $V_B SD$ angeben <i>spécifier $V_B SA$ ou $V_B SD$</i>

Il raddrizzatore è del tipo a diodi a semionda ($V_{c.c} \approx 0,45 \times V_{c.a.}$) ed è disponibile nelle versioni **NB, SB, NBR** e **SBR, SBR**, come dettagliato nella tabella seguente:

*The diode half-wave rectifier (VDC $\approx 0,45 \times VAC$) is available in versions **NB, SB, NBR** e **SBR, SBR**, as detailed in the table below:*

Bei dem Gleichrichter handelt es sich um einen Typ mit Halbwelldioden ($V_{c.c} \approx 0,45 V_{c.a.}$). Er ist in den Versionen **NB, SB, NBR** und **SBR**, gemäß den Details in der nachstehenden Tabelle, verfügbar:

*Le redresseur est du type à diodes à demi-onde ($V_{c.c} \approx 0,45 \times V_{c.a.}$) et il est disponible dans les versions **NB, SB, NBR** et **SBR, SBR**, comme indiqué de façon détaillée dans le tableau suivant :*

(36)

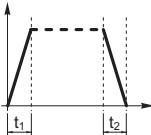
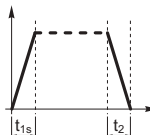
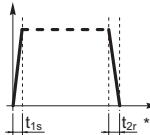
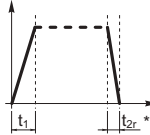
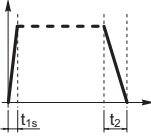
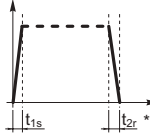
	Freno Brake Bremse Ffrein	Raddrizzatore / Rectifier Gleichrichter / Redresseur	
		standard	A richiesta / At request Auf Anfrage / Sur demande
BN 63	FD 02	NB 	SB  SBR  NBR 
BN 71	FD 03 FD 53		
BN 80	FD 04		
BN 90S	FD 14		
BN 90L	FD 05		
BN 100	FD 15		
BN 112	FD 06S	SB 	SBR 
BN 132 - 160MR	FD 56		
	FD 06 FD 07		
BN 160L - BN 180M	FD 08		
BN 180L - BN 200M	FD 09		

(*) $t_{2c} < t_{2r} < t_2$

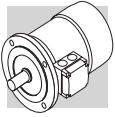

I raddrizzatore **SB** a controllo elettronico dell'eccitazione, riduce i tempi di sblocco del freno sovraccitando l'elettromagnete nei primi istanti d'inserzione, per passare poi al normale funzionamento a semionda a distacco del freno avvenuto.

*Rectifier **SB** with electronic energizing control over-energizes the electromagnet upon power-up to cut brake release response time and then switches to normal half-wave operation once the brake has been released.*

Der Gleichrichter **SB** mit elektronischer Kontrolle der Erregung reduziert die Bremslösezeiten, indem er die Bremsspannung in den ersten Momenten der Einschaltung übermäßig erregt, um dann, nach erfolgter Bremslösung, in die normale Halbwellenfunktion umzuschalten.

*Le redresseur **SB** à contrôle électronique de l'excitation réduit les temps de déblocage du frein en surexcitant l'électro-aimant durant les premiers instants d'enclenchement pour passer ensuite au fonctionnement normal à demi-onde une fois le frein désactivé.*

L'impiego del raddrizzatore tipo **SB** è sempre da prevedere nei casi di:

*Use of the **SB** rectifier is mandatory in the event of:*

Der Einsatz eines Gleichrichters vom Typ **SB** wird in folgenden Fällen empfohlen:

*L'utilisation du redresseur type **SB** doit toujours être prévue dans les cas suivants:*

- elevato numero di interventi orari
- tempi di sblocco freno ridotti
- elevate sollecitazioni termiche del freno.

- *high number of operations per hour*
- *reduced brake release response time*
- *brake is exposed to extreme thermal stress.*

- hohe Anzahl von Schaltungen pro Stunde
- schnelle Bremsansprechzeiten
- starke thermische Beanspruchungen der Bremse.

- *nombre d'interventions horaires élevé*
- *temps de déblocage frein réduits*
- *sollicitations thermiques du frein élevées.*

Per applicazioni dove è richiesto un rapido rilascio del freno sono disponibili a richiesta i raddrizzatori **NBR** o **SBR**.

*Rectifiers **NBR** or **SBR** are available for applications requiring quick brake release response.*

Für die Anwendungen, bei denen eine schnelle Ansprechzeit der Bremse gefordert wird, können auf Anfrage die Gleichrichter **NBR** oder **SBR** geliefert werden. Diese Gleichrichter erweitern die Funktion der Typen **NB** und **SB**, indem in dem elektronischen Schaltkreis ein statischer Schalter integriert ist, durch dessen Auslösen die Bremse im Fall eines Spannungsausfalls schnell abgeregt wird. Diese Lösung ermöglicht eine Verringerung der Ansprechzeiten der Bremse, wodurch weitere Schaltungen und externe Sensoren vermieden werden können. Im Hinblick auf einen besseren Einsatz der Gleichrichter **NBR** und **SBR** ist bei der Bremse eine separate Versorgung erforderlich. Verfügbare Spannungen: 230V ± 10%, 400V ± 10%, 50/60 Hz.

*Pour les applications nécessitant un déblocage rapide du frein, sur demande les redresseurs **NBR** ou **SBR** sont disponibles.*

Questi raddrizzatori completano i tipi **NB** e **SB**, integrando nel circuito elettronico un interruttore statico che interviene diseccitando rapidamente il freno in caso di mancanza di tensione.

*These rectifiers complement the **NB** and **SB** types as their electronic circuit incorporates a static switch that de-energizes the brake quickly in the event voltage is missing.*

Questa soluzione consente di ridurre i tempi di rilascio del freno evitando ulteriori cablaggi e contatti esterni.

This arrangement ensures short brake release response time with no need for additional external wiring and contacts.

Per il migliore utilizzo dei raddrizzatori **NBR** e **SBR** è richiesta l'alimentazione separata del freno.

*Optimum performance of rectifiers **NBR** and **SBR** is achieved with separate brake power supply.*

Tensioni disponibili: 230V ± 10%, 400V ± 10%, 50/60 Hz.

Available voltages: 230V ± 10%, 400V ± 10%, 50/60 Hz.

*Ces redresseurs complètent les types **NB** et **SB**, en intégrant dans le circuit électronique un interrupteur statique qui intervient en désexcitant rapidement le frein en cas de coupure de tension.*

Cette solution permet de réduire les temps de déblocage du frein en évitant d'autres câblages et contacts extérieurs.

*Pour une meilleure utilisation des redresseurs **NBR** et **SBR** l'alimentation séparée du frein est nécessaire.*

Tensions disponibles : 230V ± 10%, 400V ± 10%, 50/60 Hz.

- Dati tecnici freni FD

Nella tabella sottostante sono riportati i dati tecnici dei freni in c.c. tipo FD.

- FD brake technical specifications

The table below reports the technical specifications of DC brakes FD.

- Technische Daten - Bremstyp FD

In der nachstehenden Tabelle werden die technischen Daten der Gleichstrombremsen vom Typ FD angegeben.

- Caractéristiques techniques freins FD

Le tableau suivant indique les caractéristiques techniques des freins en c.c. type FD.

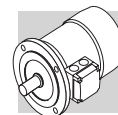

(37)

Freno Brake Bremse Frein	Coppia frenante M_b Brake torque M_b Bremsmoment M_b Couple de freinage M_b [Nm]			Rilascio Release Anspruchzeit Déblocage		Frenatura Braking Bremszeit Freinage		Wmax per frenata Wmax per brake operation Wmax pro Bremsung Wmax par freinage			W	P
	n° molle / no. of springs Feder / ressorts			t_1 [ms]	t_{1s} [ms]	t_2 [ms]	t_{2c} [ms]	[J]				
	6	4	2					10 c/h	100 c/h	1000 c/h		
FD 02	—	3.5	1.75	30	15	80	9	4500	1400	180	15	17
FD 03	5	3.5	1.75	50	20	100	12	7000	1900	230	25	24
FD 53	7.5	5	2.5	60	30	100	12					
FD 04	15	10	5	80	35	140	15	10000	3100	350	30	33
FD 14												
FD 05	40	26	13	150	65	170	20	18000	4500	500	50	45
FD 15	40	26	13	150	65	170	20					
FD 55	55	37	18	—	65	170	20	20000	4800	550	70	55
FD 06S	60	40	20	—	80	220	25					
FD 56	—	75	37	—	90	150	20	29000	7400	800	80	65
FD 06	—	100	50	—	100	150	20					
FD 07	150	100	50	—	120	200	25	40000	9300	1000	130	65
FD 08 *	250	200	170	—	140	350	30	60000	14000	1500	230	100
FD 09 **	400	300	200	—	200	450	40	70000	15000	1700	230	120

* valori di coppia frenante ottenuti con n° 9,7,6 molle rispettivamente

* brake torque values obtained with 9, 7 and 6 springs, respectively

* Werte, der durch den Einsatz von jeweils 9, 7, 6 Federn erreichten Bremsmomente

* valeurs de couple de freinage obtenues respectivement avec n° 9, 7, 6 ressorts

** valori di coppia frenante ottenuti con n° 12,9,6 molle rispettivamente

** brake torque values obtained with 12, 9 and 6 springs, respectively

** Werte, der durch den Einsatz von jeweils 12, 9, 6 Federn erreichten Bremsmomente

** valeurs de couple de freinage obtenues respectivement avec n° 12, 9, 6 ressorts

Legenda:

- t_1 = tempo di rilascio del freno con alimentatore a semionda
- t_{1s} = tempo di rilascio del freno con alimentatore con sovraeccitazione.
- t_2 = ritardo di frenatura con interruzione lato c.a. e alimentazione separata
- t_{2c} = ritardo di frenatura con interruzione lato c.a. e c.c. I valori di t_1 , t_{1s} , t_2 , t_{2c} , indicati nella tabella (37) sono riferiti al freno tarato alla coppia massima, traferro medio e tensione nominale.
- W_{max} = energia max per frenata
- W = energia di frenatura tra due regolazioni successive
- P_b = potenza assorbita dal freno a 20°C
- M_b = coppia frenante statica ($\pm 15\%$)
- c/h = avviamenti orari

Key:

- t_1 = brake release time with half-wave rectifier
- t_{1s} = brake release time with over-energizing rectifier
- t_2 = brake engagement time with AC line interruption and separate power supply
- t_{2c} = brake engagement time with AC and DC line interruption – Values for t_1 , t_{1s} , t_2 , t_{2c} indicated in the tab. (37) are referred to brake set at maximum torque, medium air gap and rated voltage
- W_{max} = max energy per brake operation
- W = braking energy between two successive air gap adjustments
- P_b = brake power absorption at 20 °C
- M_b = static braking torque ($\pm 15\%$)
- c/h = starts per hour

Legende:

- t_1 = Ansprechzeit der Bremse mit Halbwellengleichrichter
- t_{1s} = Ansprechzeit der Bremse mit elektronisch gesteuerten Erregungsgleichrichter
- t_2 = Bremsverzögerung mit Unterbrechung auf Wechselstromseite und Fremdversorgung
- t_{2c} = Bremsverzögerung mit Unterbrechung auf Wechselstrom- und Gleichstromseite – Die in der Tab. (37) angegebenen Werte t_1 , t_{1s} , t_2 , t_{2c} beziehen sich auf eine auf das max. Bremsmoment geeichte Bremse, mit mittlerem Luftspalt und Nennspannung.
- W_{max} = max. Energie pro Bremsung
- W = Bremsenergie zwischen zwei Einstellungen des Luftspalts
- P_b = bei 20° C von der Bremse aufgenommene Leistung (50 Hz)
- M_b = statisches Bremsmoment ($\pm 15\%$)
- c/h = Schaltungen pro stunde

Légende:

- t_1 = temps de déblocage du frein avec dispositif d'alimentation à demi-onde
- t_{1s} = temps de déblocage du frein avec dispositif d'alimentation à contrôle électronique de l'excitation
- t_2 = retard de freinage avec interruption côté c.a. et alimentation séparée
- t_{2c} = retard de freinage avec interruption côté c.c. Les valeurs de t_1 , t_{1s} , t_2 , t_{2c} , indiquées dans le tab. (37) se réfèrent au frein étaloné au couple maximal, entrefer moyen et tension nominale.
- W_{max} = énergie max. par freinage
- W = énergie de freinage entre deux réglages successifs de l'entrefer
- P_b = puissance absorbée par le frein à 20 °C
- M_b = couple de freinage statique ($\pm 15\%$)
- c/h = démarrages horaires

- Collegamenti freno FD

I motori standard ad una velocità sono forniti con il collegamento del raddrizzatore alla morsettiera motore già realizzata in fabbrica. Per motori a 2 velocità, e dove è richiesta l'alimentazione del freno separata, prevedere il collegamento al raddrizzatore in ac-

- FD brake connections

On standard single-pole motors, the rectifier is connected to the motor terminal board at the factory. For switch-pole motors and where a separate brake power supply is required, connection to rectifier must comply with brake voltage V_B stated in mo-

- Anschlüsse - Bremstyp FD

Die einpoligen Motoren werden vom Werk ab mit an die Motorspannung angeschlossenem Gleichrichters geliefert. Für die polumschaltbaren Motoren, und Bremse mit separater Versorgung, wird in Übereinstimmung mit der auf dem Typenschild des Motors angegebenen Brems-

- Raccordements frein FD

Les moteurs standard à une vitesse sont fournis avec le raccordement du redresseur au bornier moteur déjà réalisé en usine. Pour les moteurs à 2 vitesses, et lorsqu'une alimentation séparée du frein est requise, prévoir le raccordement au redresseur conformément à la tension

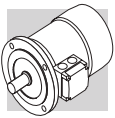

cordo alla tensione freno V_B indicata nella targhetta del motore.

Data la natura induttiva del carico, per il comando del freno e per l'interruzione lato corrente continua devono essere utilizzati contatti con categoria d'impiego AC-3 secondo IEC 60947-4-1.

for name plate.

Because the load is of the inductive type, brake control and DC line interruption must use contacts from the usage class AC-3 to IEC 60947-4-1.

spannung V_B der Anschluss an den Gleichrichter vorgesehen.

Da es sich bei der Bremsleistung um eine induktive Kraft handelt, müssen gemäß IEC 60947-4-1 für die Steuerung der Bremse und die Unterbrechung der Gleichstromseite Kontakte der Kategorie AC-3 verwendet werden.

frein V_B indiquée sur la plaque signalétique du moteur.

Etant donné la nature inductive de la charge, pour la commande du frein et l'interruption côté courant continu, il est nécessaire d'utiliser des contacts avec catégorie d'utilisation AC-3 selon la norme IEC 60947-4-1.

Tabella (38) - Alimentazione freno dai morsetti motore ed interruzione lato a.c.

Tempo di arresto t_2 ritardato e funzione delle costanti di tempo del motore.

Da prevedere quando sono richiesti avviamenti/arresti progressivi.

Tabella (39) - Bobina freno con alimentazione separata ed interruzione lato c.a.

Tempo di arresto normale ed indipendente dal motore.

Tabella (40) - Bobina freno con alimentazione dai morsetti motore ed interruzione lato c.a. e c.c.

Arresto rapido con i tempi d'intervento t_{2c} .

Tabella (41) - Bobina freno con alimentazione separata ed interruzione lato c.a. e c.c.

Tempo di arresto ridotto secondo i valori t_{2c} .

Table (38) - Brake power supply from motor terminals and AC line interruption.

Delayed stop time t_2 and function of motor time constants.

Mandatory when soft-start/stops are required.

Table (39) - Brake coil with separate power supply and AC line interruption

Normal stop time independent of motor.

Table (40) - Brake coil power supply from motor terminals and AC/DC line interruption.

Quick stop with operation times t_{2c} .

Table (41) - Brake coil with separate power supply and AC/DC line interruption.

Stop time decreases by values t_{2c} .

Tabelle (38) - Bremsversorgung über die Motorspannung und Unterbrechung der Wechselstromseite. Verzögerter und von den Zeitkonstanten des Motors abhängige Haltezeit t_2 . Vorzusehen, wenn progressive Starts/Stopp erforderlich sind.

Tabelle (39) - Bremsspule mit separater Spannungsversorgung und Unterbrechung der Wechselstromseite. Normale und vom Motor unabhängige Stoppzeiten.

Tabelle (40) - Bremsspule mit Versorgung über die Motorspannung und Unterbrechung der Gleich- und der Wechselstromseite. Schneller Stopp mit angegebenen Ansprechzeiten t_{2c} .

Tabelle (41) - Bremsspule mit separater Spannungsversorgung und Unterbrechung der Gleich- und der Wechselstromseite. Reduzierte Stoppzeiten angegebenen Werte t_{2c} .

Tableau (38) - Alimentazione freno depuis bornes moteur et interruption côté c.a.

Temps d'arrêt t_2 retardé et fonction des constantes de temps du moteur.

A prévoir lorsque des démarrages/arrests progressifs sont requis.

Tableau (39) - Bobine de frein avec alimentation séparée et interrupteur côté c.a.

Temps d'arrêt normal et indépendant du moteur.

Tableau (40) - Bobine de frein avec alimentation depuis les bornes moteur et interruption côté c.a. et c.c.

Arrêt rapide avec les temps d'intervention t_{2c} .

Tableau (41) - Bobine de frein avec alimentation séparée et interruption côté c.a. et c.c. Temps d'arrêt réduit selon les valeurs t_{2c} .

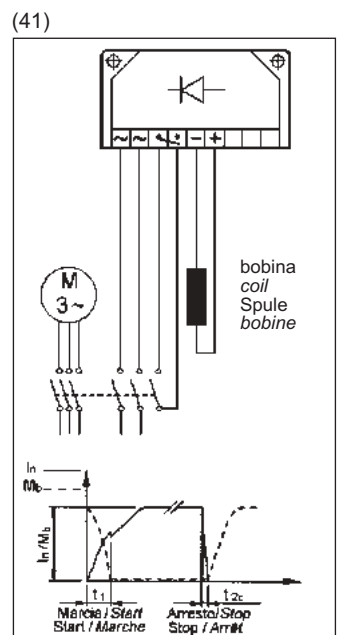
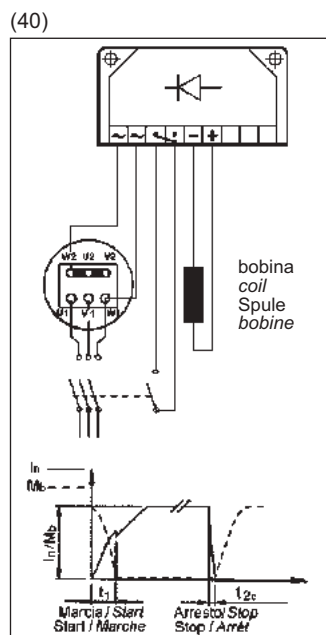
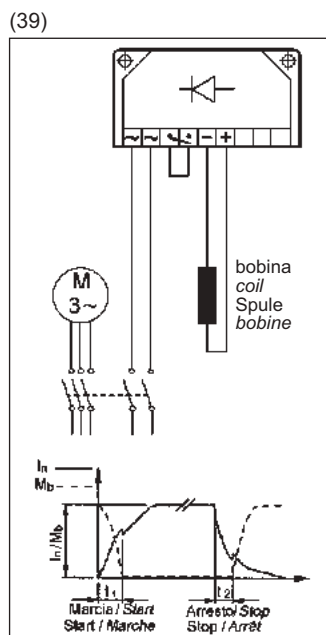
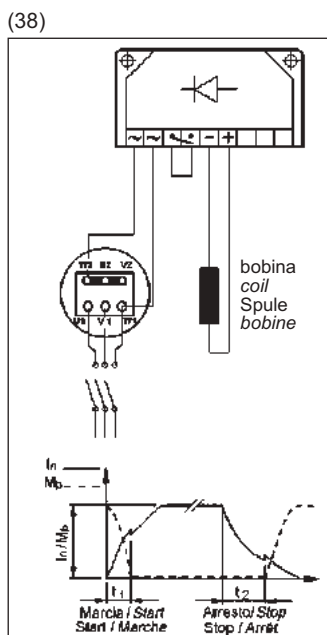

Le tabelle da (38) a (41) riportano gli schemi tipici di collegamento per alimentazione 400 V, motori 230/400V collegati a stella e freno 230 V.

Tables (38) through (41) show the typical connection diagrams for 400 V power supply, star-connected 230/400V motors and 230 V brake.

In den Tabellen (38) bis (41) werden die typischen Schaltungen für Versorgung mit 400 V, Motoren 230/400V mit Sternschaltung und einer Bremsspannung von 230 V wiedergegeben.

Les tableaux de (38) à (41) indiquent les schémas typiques de branchement pour une alimentation de 400 V, moteurs 230/400V raccordés en étoile et frein 230 V.

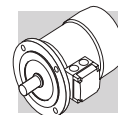

**M26 - MOTORI AUTOFRENANTI
IN C.A. TIPO BN_FA**

**M26 - AC BRAKE MOTORS
TYPE BN_FA**

**M26 - WECHSELSTROMBREMS-
MOTOREN MIT W.S.-
BREMSE TYP BN_FA**

**M26 - MOTEURS FREIN
EN C.A. TYPE BN_FA**

- **Grandezze:** BN 63 ... BN 180M

- **Frame sizes:** BN 63 ... BN 180M

- **Baugrößen:** BN 63 ... BN 180M

- **Tailles:** BN 63 ... BN 180M

(42)

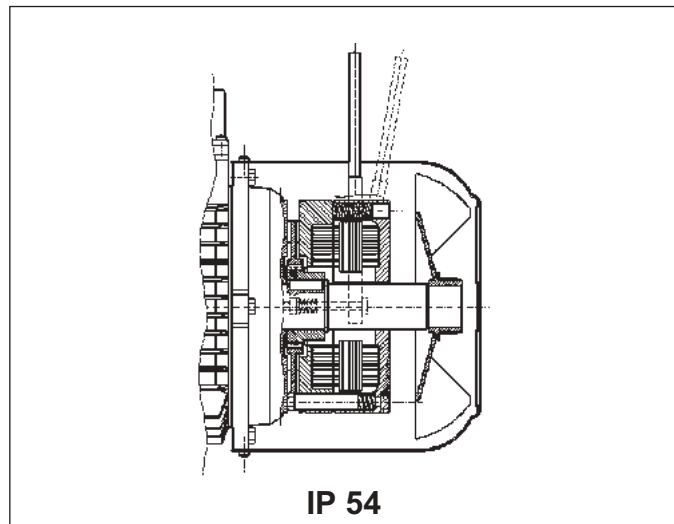

IP 54

(43)

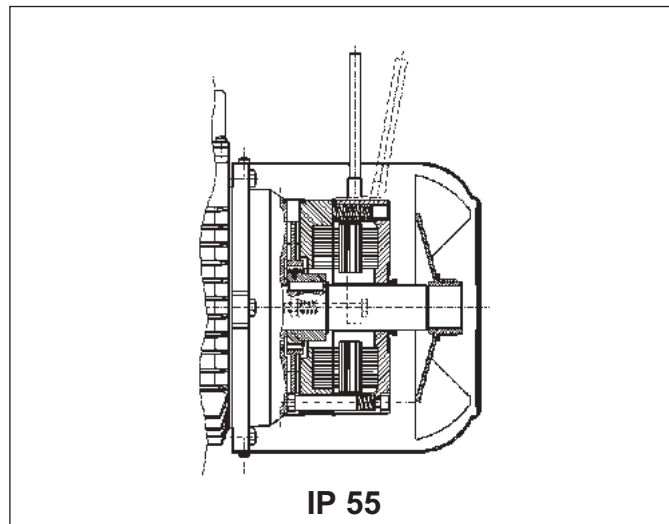

IP 55

Freno elettromagnetico con alimentazione in **corrente alternata** trifase, fissato con viti allo scudo motore; le molle di precarico realizzano il posizionamento assiale del corpo magnete.

Il disco freno è scorrevole assialmente sul mozzo trascinatore in acciaio calettato sull'albero e previsto di molla antivibrazione. La coppia frenante è preimpostata in fabbrica su valori che sono indicati nelle tabelle dati tecnici dei relativi motori.

L'azione del freno è inoltre modulabile, regolando con continuità la coppia frenante, tramite le viti che realizzano il precarico delle molle; il campo di regolazione della coppia è: $30\% M_{bMAX} < M_b < M_{bMAX}$ (M_{bMAX} è il momento frenante max riportato in tab. (46).

Il freno tipo FA presenta dinamiche molto elevate che lo rendono idoneo in applicazioni dove sono richieste frequenze di avviamento elevate con tempi d'intervento molto rapidi.

A richiesta, i motori possono essere previsti di leva per lo sblocco manuale con ritorno automatico (R). Per la specifica della posizione angolare della leva vedi relativa variante alla pag. 124.

*Electromagnetic brake operates from three-phase **alternated current** power supply and is bolted onto conveyor shield. Preloading springs provide axial positioning of magnet body.*

Steel brake disc slides axially on steel hub shrunk onto motor shaft with anti-vibration spring. Brake torque factory setting is indicated in the corresponding motor rating charts.

Spring preloading screws provide stepless braking torque adjustment. Torque adjustment range is $30\% M_{bMAX} < M_b < M_{bMAX}$ (where M_{bMAX} is maximum braking torque as shown in tab. (46).

Thanks to their high dynamic characteristics, FA brakes are ideal for heavy-duty applications as well as applications requiring frequent stop/starts and very fast response time.

Motors may be equipped with manual release lever with automatic return (R) at request. See variants at page 124 for available lever locations.

Elektromagnetische Bremse mit **Drehstromversorgung**, die mittels Schrauben am hinteren Motorschild befestigt ist. Die Federn sorgen dabei für die axiale Ausrichtung des Magnetkörpers. Die Bremsscheibe (Stahl) gleitet axial auf dem sich auf dem Rotor befindlichen Mitnehmer, der über eine Paßfeder mit Motorwelle verbunden und mit einer Schwingungsdämpffeder ausgestattet ist. Das Bremsmoment wird auf das entsprechende Motormoment eingestellt (siehe Tabelle der technischen Daten der entsprechenden Motoren). Das Bremsmoment ist stufenlos durch über die Schrauben die die Federvorspannung einstellbar. Der Einstellbereich beträgt $30\% M_{bMAX} < M_b < M_{bMAX}$ (M_{bMAX} steht für den max. Bremsmoment, der in der Tab (46) angegeben wird). Die Bremse vom Typ FA zeichnet sich durch ihre hohen Dynamik aus, weshalb sie für Anwendungen geeignet sind, in denen hohe Schaltfrequenzen und schnelle Ansprechzeiten gefordert werden. Auf Anfrage können die Motoren mit einem Lüfterhebel für die manuelle Lüftung der Bremse mit automatischer Rückstellung (R) geliefert werden. Die Angabe der Montageposition erfolgt über die Angabe der Option auf Seite 124.

*Frein électromagnétique avec alimentation en **courant alternatif** triphasé, fixé avec des vis au bouclier ; les ressorts de précharge réalisent le positionnement axial de la bobine.*

Le disque frein coulisse de façon axiale sur le moyeu d'entraînement en acier, calé sur l'arbre et doté de ressort antivibration.

Le couple de freinage est pré réglé en usine aux valeurs qui sont indiquées dans les tableaux des caractéristiques techniques des moteurs correspondants. De plus, l'action du frein est modulable, en réglant le couple de freinage en continu au moyen des vis qui réalisent la précharge des ressorts ; la plage de réglage du couple est de $30\% M_{bMAX} < M_b < M_{bMAX}$ (M_{bMAX} est le couple de freinage maximum indiqué dans le tab. (46).

Le frein type FA présente des caractéristiques dynamiques très élevées, il est donc adapté pour des applications nécessitant des fréquences de démarrage élevées et des temps d'intervention très rapides.

Sur demande, les moteurs peuvent être prévus avec levier pour le déblocage manuel avec retour automatique (R). Pour la spécification de la position angulaire du levier, voir variante page 124.

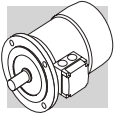

- Grado di protezione

L'esecuzione standard prevede il grado di protezione IP54.

In opzione, il motore autofrenante BN_FA viene fornito con grado di protezione **IP 55** prevedendo le seguenti varianti costruttive:

- anello V-ring posizionato sull'albero motore N.D.E.
- fascia di protezione in gomma
- anello o-ring

- Degree of protection

Standard protection is IP54.

Brake motor BN_FA is also available in protection **IP 55**, which mandates the following variants:

- V-ring at N.D.E. of motor shaft
- rubber boot
- O-ring

- Schutzart

Die Standardausführung ist Schutzart IP54 vor.

Optional kann der Bremsmotor BN_FA auch in der Schutzart IP 55 geliefert werden, was durch die folgenden zusätzlichen Bauteile erreicht wird:

- V-Ring an der Motorwelle N.D.E.
- Schutzring aus Gummi
- O-Ring

- Degré de protection

L'exécution standard prévoit le degré de protection IP54.

En option, le moteur frein BN_FA est fourni avec degré de protection **IP 55**, les variations de construction suivantes sont prévues :

- bague V-ring positionné sur l'arbre moteur N.D.E.
- bande de protection en caoutchouc
- joint torique

- Alimentazione freno FA

Nei motori a singola polarità l'alimentazione della bobina freno è derivata direttamente dalla morsettiera motore e la tensione del freno quindi coincide con la tensione del motore. In questo caso la tensione del freno può essere omessa dalla designazione.

Per i motori a doppia polarità, e per i motori con alimentazione separata del freno, è presente una morsettiera ausiliaria con 6 terminali per il collegamento alla linea del freno. In entrambi i casi il valore di tensione del freno dovrà essere specificato in designazione.

Nella tabella seguente sono riportate le condizioni di alimentazione standard del freno in c.a. per i motori a singola e doppia polarità:

- FA brake power supply

In single-pole motors, power supply is brought to the brake coil direct from the motor terminal box. As a result, brake voltage and motor voltage are the same. In this case, brake voltage indication may be omitted in the designation.

Switch-pole motors and motors with separate brake power supply feature an auxiliary terminal board with 6 terminals for connection to brake line. In both cases, brake voltage indication in the designation is mandatory. The following table reports standard AC brake power supply ratings for single- and switch-pole motors:

- Stromversorgung - Bremstyp FA

Bei den einpoligen Motoren wird die Versorgung der Bremsspule direkt vom Motorklemmenkasten abgenommen, das bedeutet, dass die Spannung der Bremse mit der Motorspannung übereinstimmt. In diesem Fall braucht die Bremsenspannung nicht extra angegeben werden.

Für die polumschaltbaren Motoren und für eine separate Bremsversorgung ist eine Hilfsklemmenleiste mit 6 Anschlüssen vorgesehen, die einen Anschluß der Bremse ermöglichen. In beiden Fällen muss die Bremsspannung in der Bestellung angegeben werden.

In der nachstehenden Tabelle werden für die einpoligen und die polumschaltbaren Motoren die Standardspannungen der Wechselstrombremsen angegeben:

- Alimentation frein FA

Sur les moteurs à simple polarité, l'alimentation de la bobine frein dérive directement du bornier moteur, par conséquent, la tension du frein coïncide avec la tension du moteur. Dans ce cas, la tension du frein peut être omise de la désignation.

Pour les moteurs à double polarité et les moteurs avec alimentation séparée du frein, une boîte à bornes auxiliaire avec 6 bornes pour le raccordement à la ligne du frein, est présente. Dans les deux cas, la valeur de tension du frein doit être spécifiée dans la désignation. Le tableau suivant indique les conditions d'alimentation standard du frein en c.a. pour les moteurs à simple et double polarité :

(44)	Motori a singola polarità Single-speed motors Einpolige Motoren Moteurs à simple polarité	BN 63 ... BN 132	BN 160 ... BN 180 M
		230Δ / 400Y V ±10% – 50 Hz	400Δ / 690Y V ±10% – 50 Hz
		265Δ / 460Y V ±10% - 60 Hz	460Δ V – 60 Hz

(45)	Motori a doppia polarità (alimentazione da linea separata) Switch-speed motors (separate power supply line) Polumschaltbare Motoren (separate Versorgung) Moteurs à double polarité (alimentation depuis ligne séparée)	BN 63 ... BN 132
		230Δ / 400Y V ±10% – 50 Hz
		460Y V – 60 Hz

Su richiesta, sono disponibili tensioni speciali, nel campo 24...690 V, 50... 60 Hz.

Special voltages in the 24...690 V, 50... 60 Hz range are available at request.

Auf Anfrage können Sonderspannungen von 24...690 V, 50... 60 Hz geliefert werden.

Sur demande, des tensions spéciales sont disponibles dans la plage 24...690 V, 50... 60 Hz.

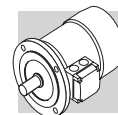

- Dati tecnici freni FA

- FA brake technical specifications

- Technische Daten der Bremsen vom Typ FA

- Caractéristiques techniques freins FA

(46)

	Freno Brake Bremse Frein	Coppia frenante M_b Brake torque M_b Bremsmoment M_b Couple de freinage M_b	Rilascio Release Anspruchzeit Déblocage	Frenatura Braking Bremszeit Freinage	W max			W	P _b
					[J]				
		[Nm]	t ₁ [ms]	t ₂ [ms]	10 c/h	100 c/h	1000 c/h	[MJ]	[VA]
	FA 02	3.5	4	20	4500	1400	180	15	60
	FA 03	7.5	4	40	7000	1900	230	25	80
	FA 04	15	6	60	10000	3100	350	30	110
	FA 14								
	FA 05	40	8	90	18000	4500	500	50	250
	FA 15								
	FA 06S	60	16	120	20000	4800	550	70	470
	FA 06	75	16	140	29000	7400	800	80	550
	FA 07	150	16	180	40000	9300	1000	130	600
	FA 08	250	20	200	60000	14000	1500	230	1200

Legenda:

M_b = max coppia frenante statica (± 15%)
 t_1 = tempo di rilascio del freno
 t_2 = ritardo di frenatura
 W_{max} = energia max per frenata (capacità termica del freno)
 W = energia di frenatura tra due regolazioni successive del traferro
 P_b = potenza assorbita dal freno a 20°C (50 Hz)
 c/h = avviamenti orari

Key:

M_b = max static braking torque (15%)
 t_1 = brake release time
 t_2 = brake engagement time
 W_{max} = max energy per brake operation (brake thermal capacity)
 W = braking energy between two successive air gap adjustments
 P_b = brake power absorption at 20° (50 Hz)
 c/h = starts per hour

Legende:

M_b = statisches max. Bremsmoment (± 15%)
 t_1 = Bremsenansprechzeit
 t_2 = Bremsverzögerung
 W_{max} = max. Energie pro Bremsung (Wärmeleistung der Bremse)
 W = Bremsenergie zwischen zwei Einstellungen des Luftspalts
 P_b = bei 20° von der Bremse aufgenommene Leistung (50 Hz)
 c/h = Schaltungen pro stunde

Légende:

M_b = couple de freinage statique max (15%)
 t_1 = temps de déblocage frein
 t_2 = retard de freinage
 W_{max} = énergie max par freinage (capacité thermique du frein)
 W = énergie de freinage entre deux réglages successifs de l'entrefer
 P_b = puissance absorbée par le frein à 20° (50 Hz)
 c/h = démarrages horaires

N.B.

I valori di t_1 e t_2 riportati in tabella sono riferiti al freno tarato alla coppia nominale, traferro medio e tensione nominale.

NOTE

Values t_1 and t_2 in the table refer to a brake set at rated torque, medium air gap and rated voltage.

HINWEIS:

Die in der Tabelle angegebenen Werte t_1 und t_2 beziehen sich auf eine Bremse, die auf das Nenndrehmoment, einen mittleren Luftspalt und die Standardspannung eingestellt ist.

N.B.

Les valeurs de t_1 et t_2 indiquées dans le tableau se réfèrent au frein étalonné au couple nominal, entrefer moyen et tension nominale.

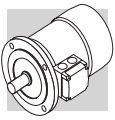

- Collegamenti freno FA

- FA brake connections

- Abschlüsse - Bremstyp FA

- Raccordements frein FA

Per i motori con alimentazione del freno derivata direttamente dall'alimentazione motore i collegamenti alla morsetteria corrispondono a quanto riportato nello schema (47):

The diagram (47) shows the required connections to terminal box when brake is to be connected directly to motor power supply:

Bei den Motoren mit direkter Bremsspannungsversorgung müssen die Anschlüsse im Klemmenkasten entsprechend den Angaben im Schema (47) angeschlossen werden:

Pour les moteurs avec alimentation du frein dérivant directement de l'alimentation moteur, les raccordements à la boîte à bornes correspondent aux indications du schéma (47) :

(47)

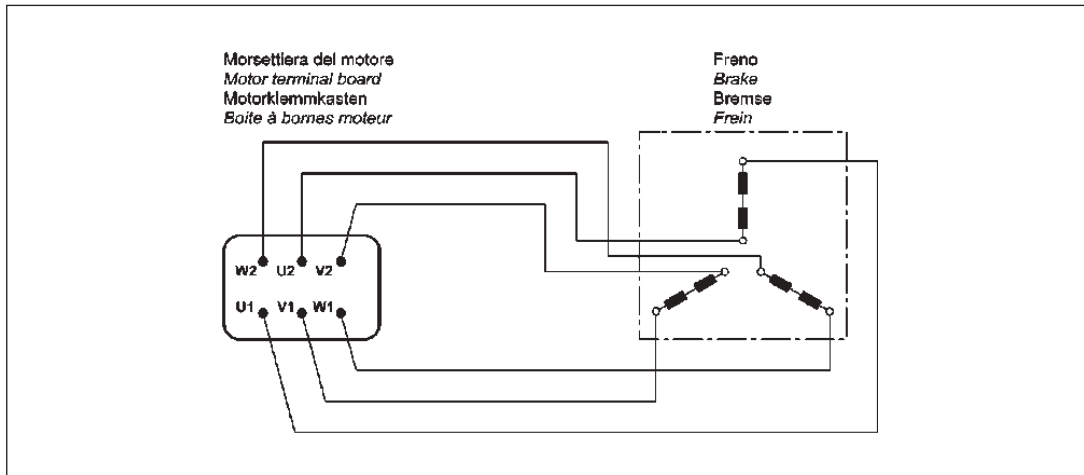

Per i motori a doppia polarità e, quando richiesto, per i motori ad una velocità con alimentazione da linea separata è prevista una morsetteria ausiliaria a 6 morsetti per il collegamento del freno; in questa esecuzione i motori prevedono la scatola coprimorsetti maggiorata. Vedi schema (48):

Switch-pole motors and, at request, single-pole motors with separate power supply line are equipped with an auxiliary terminal board with 6 terminals for brake connection. In this version, motors feature a larger terminal box. See diagram (48):

Bei den polumschaltbaren Motoren und, auf Anfrage, auch bei den einpoligen Motoren mit separater Bremsversorgung ist für den Anschluss der Bremse ein Hilfsklemmenkasten mit 6 Klemmen vorgesehen. In diesen Ausführungen haben die Motoren einen größeren Klemmenkasten. Siehe Schema (48):

Pour les moteurs à double polarité et, lorsque cela est requis, pour les moteurs à une vitesse avec alimentation depuis ligne séparée, une boîte à bornes auxiliaire à 6 bornes est prévue pour le raccordement du frein ; dans cette exécution les moteurs prévoient un couvercle bornier majoré. Voir schéma (48) :

(48)

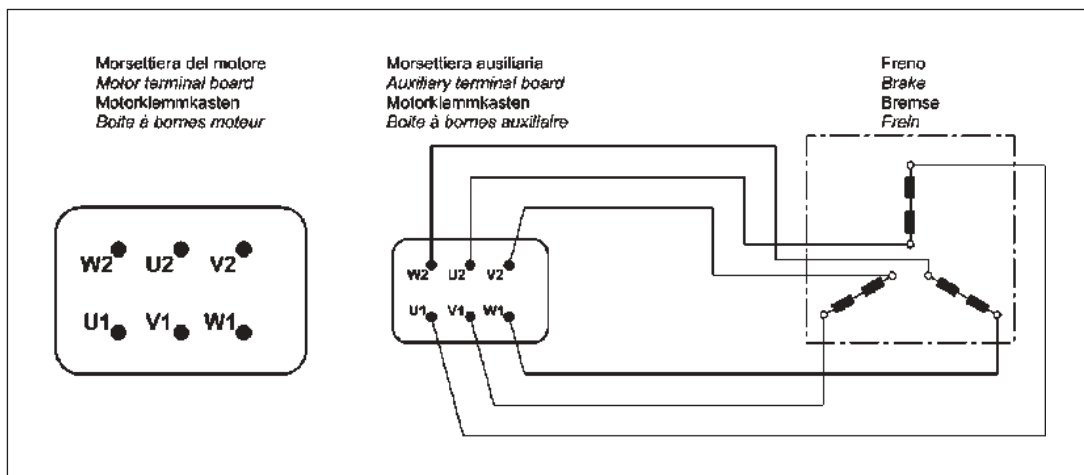

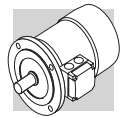

**M27 - MOTORI AUTOFRENANTI
IN C.A. TIPO BN_BA**

**M27 - AC BRAKE MOTORS
TYPE BN_BA**

**M27 - WECHSELSTROMBREMS-
MOTOREN MIT W.S.-
BREMSE TYP BN_BA**

**M27 - MOTEURS FREIN EN C.A.
TYPE BN_BA**

- **Grandezze:** BN 63 ... BN 132M

- **Frame sizes:** BN 63 ... BN 132M

- **Baugrößen:** BN 63 ... BN 132M

- **Tailles :** BN 63 ... BN 132M

(49)

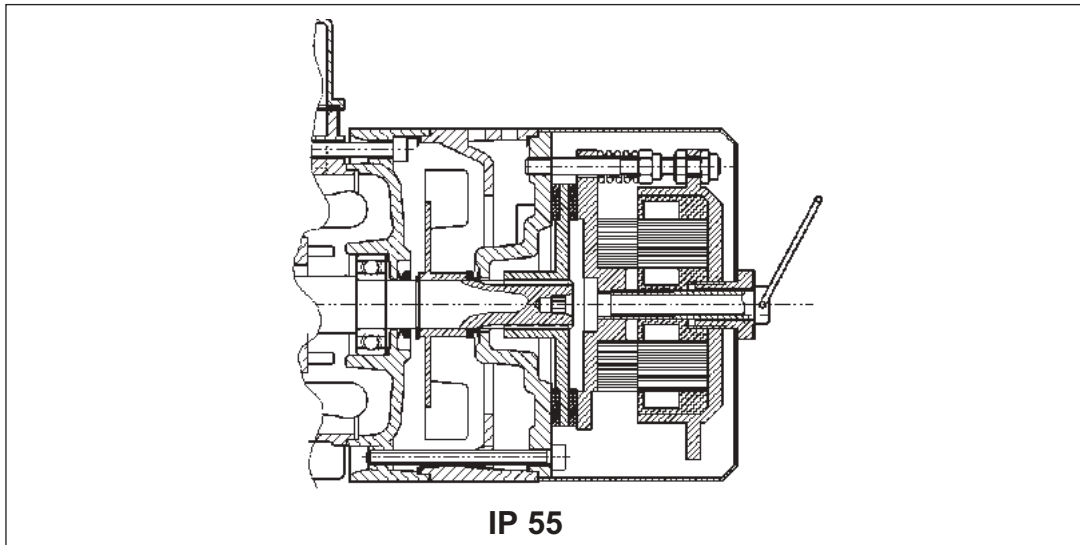

Freno elettromagnetico con alimentazione in **corrente alternata** trifase, fissato con viti allo scudo convogliatore.

Disco freno in acciaio scorrevole assialmente sull'albero motore scanalato (mozzo trascinato in acciaio calettato sull'albero per grandezza 132).

I motori sono forniti con freno tarato alla massima coppia. La coppia freno è regolabile con continuità agendo sulle viti di compressione delle molle; il campo di regolazione consentito è $30\% M_{bMAX} < M_b < M_{bMAX}$ (M_{bMAX} è il momento frenante max riportato in tab. (52)).

Di serie i motori sono forniti completi di vite per lo sblocco manuale del freno, con mantenimento della posizione di rilascio per consentire la rotazione dell'albero motore.

La vite di sblocco deve essere smontata dopo l'utilizzo per assicurare il corretto funzionamento del freno ed evitare situazioni potenzialmente pericolose.

Il freno BA, oltre alle elevate caratteristiche dinamiche tipiche dei freni in corrente alternata, presenta una costruzione robusta con energia di frenatura aumentata che lo rendono particolarmente idoneo a servizi pesanti oltre che in applicazioni dove sono richieste frequenze di manovra elevate e tempi d'intervento molto rapidi.

*Electromagnetic brake operates from three-phase **alternated current** power supply and is bolted onto conveyor shield.*

Steel brake disc slides axially on splined motor shaft (steel drive hub is shrunk onto shaft on frame size 132).

Factory setting is maximum brake torque.

Step less braking torque adjustment by screws which compress the brake springs. Allowed adjustment range is $30\% M_{bMAX} < M_b < M_{bMAX}$ (M_{bMAX} is maximum braking torque as shown in tab. (52)).

Motors are supplied complete with manual brake release screw as standard. Screw may be locked in the release position to allow for motor shaft rotation.

The brake release screw must be removed after use to ensure proper brake operation and avoid potentially dangerous conditions.

In addition to the high dynamic characteristics typical of AC brakes, a sturdy design and increased braking energy make the BA brake ideal for heavy-duty applications as well as applications requiring frequent stop/starts and very fast response time.

Elektromagnetische Bremse mit Drehstromversorgung, die mittels Schrauben am Motorschild des Motors befestigt ist. Die Bremscheibe (Stahl) gleitet axial auf der Rotorwelle (bei Baugröße 132 über einem auf die Welle aufgezogenem Mitnehmer aus Stahl). Die Motoren werden mit einer auf das maximale Drehmoment des Motors eingestellten Bremse geliefert. Das Bremsdrehmoment ist durch Betätigen der Federdruckschrauben stufenlos regelbar. Der zulässige Einstellbereich beträgt $30\% M_{bMAX} < M_b < M_{bMAX}$ (M_{bMAX} steht für den max. Bremsmoment, das in der Tab. (52) angegeben wird).

Die Motoren werden serienmäßig mit einer Schraube zur manuelle Bremslüftung geliefert; die arretierbar ist, um ein Drehen der Motorwelle zu ermöglichen. Diese Schraube muss im Betrieb des Motors wieder abmontiert werden, damit die korrekte Funktion der Bremse gesichert ist Die Bremse vom Typ BA zeichnet sich durch ihre dynamischen Eigenschaften und die robuste Bauweise aus, durch die sie eine erhöhte Bremsenergie abzugeben kann. Diese Bremstypen eignen sich besonders für einen Einsatz unter harten Bedingungen und überall dort, wo häufige Schaltfrequenzen und schnelle Ansprechzeiten gefordert werden.

*Frein électromagnétique avec alimentation en **courant alternatif** triphasé, fixé avec des vis au bouclier.*

Disque frein en acier coulissant de façon axiale sur l'arbre moteur rainuré (moyeu d'entraînement en acier calé sur l'arbre pour la taille 132).

Les moteurs sont fournis avec frein étalonné au couple maximal. Le couple de freinage est réglable en continu en intervenant sur les vis de compression des ressorts ; la plage de réglage autorisé est de $30\% M_{bMAX} < M_b < M_{bMAX}$ (M_{bMAX} étant le couple de freinage maximum indiqué dans le tab. (52)).

De série, les moteurs sont fournis avec vis de déblocage manuel du frein, avec maintien de la position de relâchement afin de permettre la rotation de l'arbre moteur.

La vis de déblocage doit être démontée après utilisation afin de garantir le fonctionnement correct du frein et d'éviter les situations potentiellement dangereuses. Le frein BA, outre les caractéristiques dynamiques élevées typiques des freins en courant alternatif, est de fabrication robuste avec énergie de freinage majorée, ce qui le rend particulièrement adapté pour les services difficiles ainsi que pour les applications nécessitant des fréquences de manœuvre élevées et des temps d'intervention très rapides.

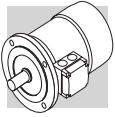

- Grado di protezione

È disponibile un'unica esecuzione, con grado di protezione IP55.

- Degree of protection

Only available with degree of protection IP55.

- Schutzart

Es ist eine nur die Ausführung in Schutzklasse IP55 verfügbar.

- Degré de protection

Il est disponible en une exécution unique, avec degré de protection IP55.

- Alimentazione freno BA

Nei motori a singola polarità l'alimentazione della bobina freno è derivata direttamente dalla morsettiera motore e la tensione del freno quindi coincide con la tensione del motore. In questo caso la tensione del freno può essere omessa dalla designazione.

Per i motori a doppia polarità, e per i motori con alimentazione separata del freno, è presente una morsettiera ausiliaria con 6 terminali per il collegamento alla linea del freno. In entrambi i casi il valore di tensione del freno dovrà essere specificato in designazione.

Nella tabella seguente sono riportate le condizioni di alimentazione standard del freno in c.a. per i motori a singola e doppia polarità:

- BA brake power supply

In single-pole motors, power supply is brought to the brake coil direct from the motor terminal box. As a result, brake voltage and motor voltage are the same. In this case, brake voltage indication may be omitted in the designation.

Switch-pole motors and motors with separate brake power supply feature an auxiliary terminal board with 6 terminals for connection to brake line. In both cases, brake voltage indication in the designation is mandatory. The following table reports standard AC brake power supply ratings for single- and switch-pole motors:

- Stromversorgung - Bremstyp BA

Bei den einpoligen Motoren wird die Versorgung der Bremsenspule direkt vom Motorklemmenkasten abgezweigt, das bedeutet also, dass die Spannung der Bremse mit der Motorspannung übereinstimmt. In diesem Fall braucht die Bremsenspannung nicht extra angegeben werden. Für polumschaltbaren Motoren und für eine separate Bremsversorgung ist eine Hilfsklemmenleiste mit 6 Anschlüssen vorgesehen, die einen Anschluss der Bremse ermöglichen. In beiden Fällen muss die Bremsenspannung bei der Bestellung angegeben werden.

In der nachstehenden Tabelle werden für die einpoligen und die polumschaltbaren Motoren die Standardversorgung der Wechselstrombremsen angegeben.

- Alimentation frein BA

Sur les moteurs à simple polarité, l'alimentation de la bobine frein dérive directement du bornier moteur, par conséquent, la tension du frein coïncide avec la tension du moteur. Dans ce cas, la tension du frein peut être omise de la désignation.

Pour les moteurs à double polarité et les moteurs avec alimentation séparée du frein, un boîte à bornes auxiliaire avec 6 bornes pour le raccordement au réseau du frein, est présente. Dans les deux cas, la valeur de tension du frein doit être spécifiée dans la désignation.

Le tableau suivant indique les conditions d'alimentation standard du frein en c.a. pour les moteurs à simple et double polarité :

(50)	Motori a singola polarità <i>Single-speed motors</i> Einpolige Motoren <i>Moteurs à simple polarité</i>	BN 63 ... BN 132
		230Δ / 400Y V ± 10% – 50 Hz
		265Δ / 460Y ± 10% - 60 Hz

(51)	Motori a doppia polarità (alimentazione da linea separata) <i>Switch-pole motors</i> (separate power supply line) Polumschaltbare Motoren (separate Versorgung) <i>Moteurs à double polarité</i> (alimentation depuis ligne séparée)	BN 63 ... BN 132
		230Δ / 400Y V ± 10% – 50 Hz
		460Y – 60 Hz

Se non diversamente specificato, l'alimentazione standard del freno è 230Δ / 400Y V - 50 Hz.

Su richiesta, sono disponibili tensioni speciali, nel campo 24...690 V, 50... 60 Hz.

Unless otherwise specified, standard brake power supply is 230Δ / 400Y V - 50 Hz.

Special voltages in the 24...690 V, 50... 60 Hz range are available at request.

Falls nicht anderweitig angegeben, beträgt die Standardversorgung der Bremse 230Δ / 400Y V - 50 Hz.

Auf Anfrage können Sonderspannungen von 24...690 V, 50... 60 Hz geliefert werden.

Sauf spécification contraire, l'alimentation standard du frein est 230Δ / 400Y V - 50 Hz.

Sur demande, des tensions spéciales sont disponibles dans la plage 24...690 V, 50... 60 Hz.

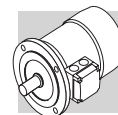

- Dati tecnici freni BA

Nella tabella sottostante sono riportati i dati tecnici dei freni in c.a., tipo BA.

- BA brake technical specifications

The table below reports the technical specifications for AC brakes type BA.

- Technische Daten der Bremsen vom Typ BA

In der nachstehenden Tabelle werden die technischen Daten der Wechselstrombremsen vom Typ BA angegeben:

- Caractéristiques techniques freins BA

Le tableau ci-dessous indique les caractéristiques techniques des freins en c.a., type BA.

(52)

Freno Brake Bremsen Frein	Coppia frenante M_b Brake torque M_b Bremsmoment M_b Couple de freinage M_b	Rilascio Release Anspruchzeit Déblocage	Frenatura Braking Bremszeit Freinage	W max			W	Pb
				[J]				
				10 c/h	100 c/h	1000 c/h		
BA 60	5	5	20	4000	1500	180	30	60
BA 70	8	6	25	7000	2700	300	60	75
BA 80	18	6	25	10000	3100	350	80	110
BA 90	35	8	35	13000	3600	400	88	185
BA 100	50	8	35	18000	4500	500	112	225
BA 110	75	8	35	28000	6800	750	132	270
BA 140	150	15	60	60000	14000	1500	240	530

Legenda:

M_b = max coppia frenante statica ($\pm 15\%$)
 t_1 = tempo di rilascio del freno
 t_2 = ritardo di frenatura
 W_{max} = energia max per frenata (capacità termica del freno)
 W = energia di frenatura tra due regolazioni successive del traferro
 P_b = potenza assorbita dal freno a 20°C (50 Hz)
 c/h = avviamenti orari

Legenda:

M_b = max static braking torque (15%)
 t_1 = brake release response time
 t_2 = brake engagement time
 W_{max} = max energy per brake operation (brake thermal capacity)
 W = braking energy between two successive air gap adjustments
 P_b = brake power absorption at 20° (50 Hz)
 c/h = starts per hour

Legende:

M_b = statisches max. Bremsmoment ($\pm 15\%$)
 t_1 = Bremsenansprechzeit
 t_2 = Bremsverzögerung
 W_{max} = max. Energie pro Bremsung (Wärmeleistung der Bremse)
 W = Bremsenergie zwischen zwei Einstellungen des Luftspalts
 P_b = bei 20° von der Bremse aufgenommene Leistung (50 Hz)
 c/h = Schaltungen pro Stunde

Légende:

M_b = couple de freinage statique max (15%)
 t_1 = temps de déblocage frein
 t_2 = retard de freinage
 W_{max} = énergie max par freinage (capacité thermique du frein)
 W = énergie de freinage entre deux réglages successifs de l'entrefer
 P_b = puissance absorbée par le frein à 20° (50 Hz)
 c/h = démarrages horaires

N.B.

I valori di t_1 e t_2 riportati in tabella sono riferiti al freno tarato alla coppia nominale, traferro medio e tensione nominale.

NOTE :

Values t_1 and t_2 in the table refer to a brake set at rated torque, medium air gap and rated voltage.

HINWEIS:

Die in der Tabelle angegebenen Werte t_1 und t_2 beziehen sich auf eine Bremse, die auf das Nenndrehmoment, einen mittleren Luftspalt und die Standardspannung eingestellt ist.

N.B.

Les valeurs de t_1 et t_2 indiquées dans le tableau se réfèrent au frein étalonné au couple nominal, entrefer moyen et tension nominale.

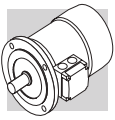

- Collegamenti freno BA

- BA brake connections

- Anschlüsse - Bremstyp BA

- Raccordements frein BA

Per i motori con alimentazione del freno derivata direttamente dall'alimentazione motore i collegamenti alla morsetteria corrispondono a quanto riportato nello schema (53):

The diagram (53) shows the required connections to terminal box when brake is to be connected directly to motor power supply:

Bei den Motoren mit einer direkt von der Motorspannung gespeisten Bremsversorgung müssen die Bremsen entsprechend der Angaben im Schema (53) angeschlossen werden:

Pour les moteurs avec alimentation du frein dérivant directement de l'alimentation moteur, les raccordements à la boîte à bornes correspondent aux indications du schéma (53) :

(53)

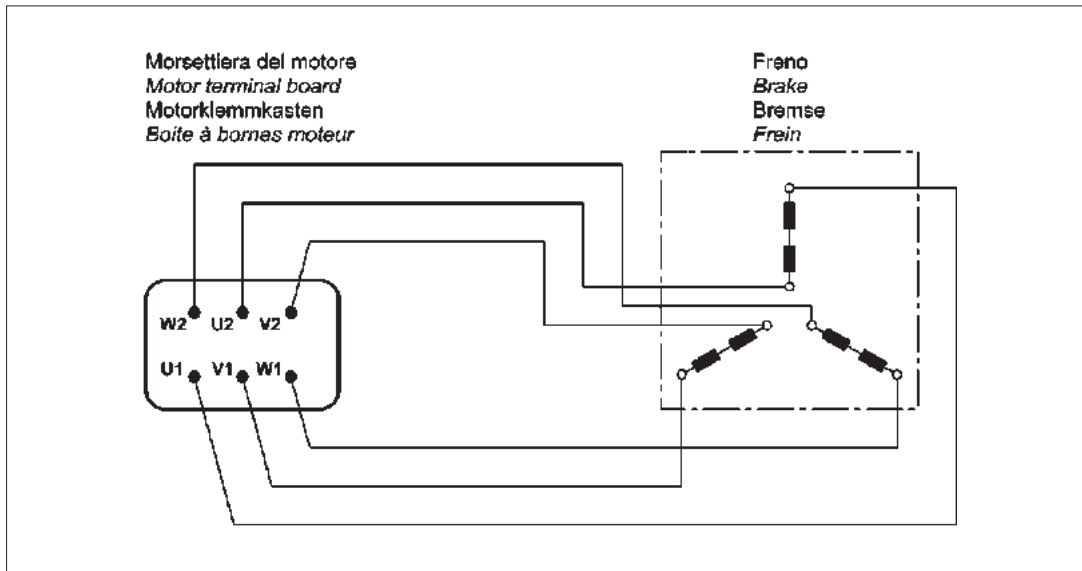

Per i motori a doppia polarità e, quando richiesto, per i motori ad una velocità con alimentazione da linea separata è prevista una morsetteria ausiliaria a 6 morsetti per il collegamento del freno; in questa esecuzione i motori prevedono la scatola coprimorsetti maggiorata. Vedi schema (54):

Switch-pole motors and, at request, single-pole motors with separate power supply line are equipped with an auxiliary terminal board with 6 terminals for brake connection. In this version, motors feature a larger terminal box. See diagram (54):

Bei den polumschaltbaren Motoren und, auf Anfrage, auch bei den eintpoligen Motoren mit separater Bremsversorgung ist für den Anschluss der Bremse ein Hilfsklemmenkasten mit 6 Klemmen vorgesehen. In dieser Ausführungen haben die Motoren einen größeren Klemmenkasten. Siehe Schema (54):

Pour les moteurs à double polarité et, lorsque cela est requis, pour les moteurs à une vitesse avec alimentation depuis ligne séparée, une boîte à bornes auxiliaire à 6 bornes est prévue pour le raccordement du frein ; dans cette exécution les moteurs prévoient un couvercle bornier majoré. Voir schéma (54) :

(54)

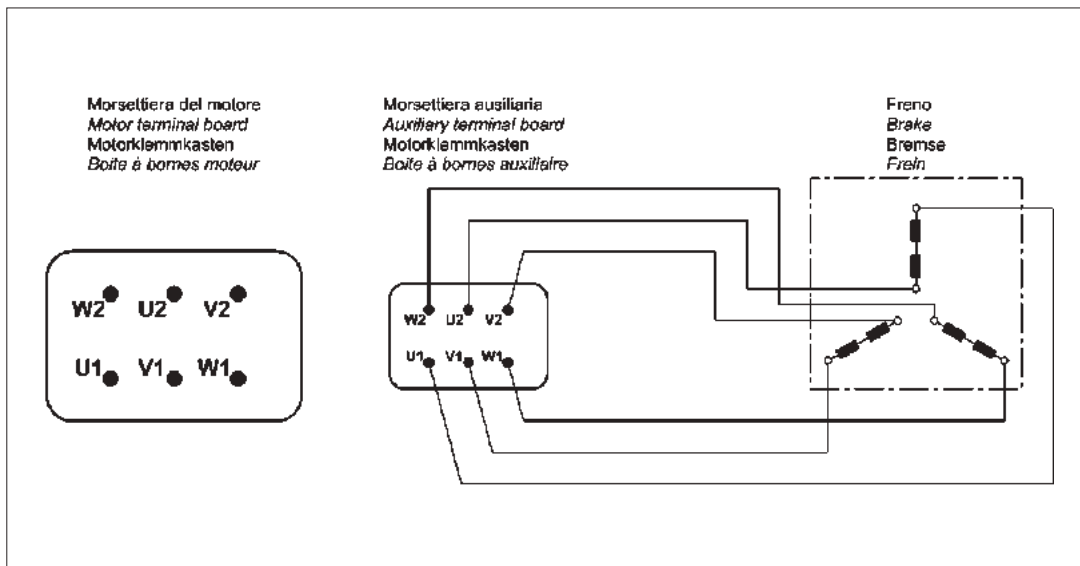

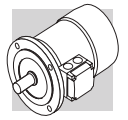

M28 - DATI TECNICI MOTORI

M28 - MOTOR RATING CHARTS

**M28 - MOTORENAUSWAHL-
TABELLEN**



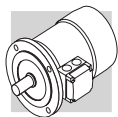

***M28 - DONNEES TECHNIQUES
DES MOTEURS***



2 P

3000 min⁻¹ - S1

50 Hz



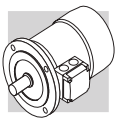

Ph kW		n min ⁻¹	Mn Nm		η (100%) %	η (75%) %	cos ϕ	In [400V] A	Is In	Ms Mn	Ma Mn	Jm $\times 10^{-4}$ kgm ²	IMB5 	freno c.c. / d.c. brake G.S.-bremse / frein c.c.				freno c.a. / a.c. brake W.S.-bremse / frein c.a.											
														FD		FA		BA		FD		FA		BA					
														Mod.	Nm	Mb 1/h NB	Zo	Jm $\times 10^{-4}$ kgm ²	IMB5 	Mod.	Nm	Mb 1/h	Zo	Jm $\times 10^{-4}$ kgm ²	IMB5 	Mod.	Nm	Mb max	Zo
0.18	BN 63A	2	2730	0.63	59.9	56.9	0.77	0.56	3.0	2.1	2	2.0	3.5	FD 02	1.75	3900	4800	2.6	5.2	FA 02	1.75	4800	2.6	5.0	BA 60	5	3500	4.0	5.8
0.25	BN 63B	2	2740	0.87	66.0	64.8	0.76	0.72	3.3	2.3	2.3	2.3	3.9	FD 02	1.75	3900	4800	3.0	5.6	FA 02	1.75	4800	3.0	5.4	BA 60	5	3600	4.3	6.2
0.37	BN 63C	2	2800	1.26	69.1	66.8	0.78	0.99	3.9	2.6	2.6	3.3	5.1	FD 02	3.5	3600	4500	3.9	6.8	FA 02	3.5	4500	3.9	6.6	BA 60	5	3500	5.3	7.4
0.37	BN 71A	2	2820	1.25	73.8	73.0	0.76	0.95	4.8	2.8	2.6	3.5	5.4	FD 03	3.5	3000	4100	4.6	8.1	FA 03	3.5	4200	4.6	7.8	BA 70	8	3500	5.5	9.3
0.55	BN 71B	2	2820	1.86	76.0	75.8	0.76	1.37	5.0	2.9	2.8	4.1	6.2	FD 03	5	2900	4200	5.3	8.9	FA 03	5	4200	5.3	8.6	BA 70	8	3600	6.1	10.1
0.75	BN 71C	2	2810	2.6	76.6	76.2	0.76	1.86	5.1	3.1	2.8	5.0	7.3	FD 03	5	1900	3300	6.1	10	FA 03	5	3600	6.1	9.7	BA 70	8	3200	7.0	11.2
0.75	BN 80A	2	2810	2.6	76.2	75.5	0.81	1.75	4.8	2.6	2.2	7.8	8.6	FD 04	5	1700	3200	9.4	12.5	FA 04	5	3200	9.4	12.4	BA 80	18	2800	10.8	13.9
1.1	BN 80B	2	2800	3.8	76.4	76.2	0.81	2.57	4.8	2.8	2.4	9.0	9.5	FD 04	10	1500	3000	10.6	13.4	FA 04	10	3000	10.6	13.3	BA 80	18	2700	12.0	14.8
1.5	BN 80C	2	2800	5.1	79.1	79.5	0.81	3.4	4.9	2.7	2.4	11.4	11.3	FD 04	15	1300	2600	13.0	15.2	FA 04	15	2600	13.0	15.1	BA 80	18	2400	14.4	16.6
1.5	BN 90SA	2	2870	5.0	82.0	81.5	0.80	3.3	5.9	2.7	2.6	12.5	12.3	FD 14	15	900	2200	14.1	16.5	FA 14	15	2200	14.1	16.4	BA 90	35	1600	19.5	19.6
1.85	BN 90SB	2	2880	6.1	82.5	82.0	0.80	4.0	6.2	2.9	2.6	16.7	14	FD 14	15	900	2200	18.3	18.2	FA 14	15	2200	18.3	18.1	BA 90	35	1700	23.7	21.3
2.2	BN 90L	2	2880	7.3	82.7	82.1	0.80	4.8	6.3	2.9	2.7	16.7	14	FD 05	26	900	2200	21	20	FA 05	26	2200	21	20.7	BA 90	35	1700	24	21.3
3	BN 100L	2	2860	10.0	82.8	82.6	0.79	6.6	5.7	2.6	2.2	31	20	FD 15	26	700	1600	35	26	FA 15	26	1600	35	27	BA 100	50	1300	43	30
4	BN 100LB	2	2870	13.3	84.3	84.4	0.80	8.6	5.9	2.7	2.5	39	23	FD 15	40	450	900	43	29	FA 15	40	1000	43	30	BA 100	50	850	51	33
4	BN 112M	2	2900	13.2	85.5	84.5	0.82	8.2	6.9	3	2.9	57	28	FD 06S	40	—	950	66	39	FA 06S	40	950	66	40	BA 110	75	850	73	41
5.5	BN 132SA	2	2890	18.2	86.1	85.7	0.84	11.0	6	2.6	2.2	101	35	FD 06	50	—	600	112	48	FA 06	50	600	112	49	BA 140	150	500	151	67
7.5	BN 132SB	2	2900	25	87.2	87.1	0.85	14.6	6.4	2.6	2.2	145	42	FD 06	50	—	550	154	55	FA 06	50	550	154	56	BA 140	150	450	195	74
9.2	BN 132M	2	2930	30	89.0	88.5	0.86	17.3	6.9	2.8	2.3	178	53	FD 56	75	—	430	189	66	FA 06	75	430	189	67	BA 140	150	400	228	85
11	BN 160MR	2	2920	36	89.1	88.9	0.88	20.2	7.0	2.9	2.5	210	65																
15	BN 160MB	2	2930	49	89.6	89.4	0.86	28.1	7.1	2.6	2.3	340	84																
18.5	BN 160L	2	2930	60	90.4	90.1	0.86	34	7.6	2.7	2.3	420	97																
22	BN 180M	2	2930	72	91.3	91.3	0.88	40	7.8	2.6	2.4	490	109																
30	BN 200LA	2	2930	98	91.9	91.4	0.89	53	7.9	2.7	2.9	770	140																







6 P

1000 min⁻¹ - S1

50 Hz

Pn kW		n min ⁻¹	Mn Nm	η %	cos φ	In [400V] A	Is In	Ms Mn	Ma Mn	Jm x 10 ⁻⁴ kgm ²	IM B5 	freno c.c. / d.c. brake G.S.-bremse / frein c.c.						freno c.a. / a.c. brake W.S.-bremse / frein c.a.											
												FD			FA			BA			FD			FA			BA		
												Mod.	Mb Nm	Zo 1/h NB SB	Jm x 10 ⁻⁴ kgm ²	IM B5 	Mod.	Mb Nm	Zo 1/h	Jm x 10 ⁻⁴ kgm ²	IM B5 	Mod.	Mb Nm	Zo 1/h	Jm x 10 ⁻⁴ kgm ²	IM B5 			
0.09	BN 63A	6	0.98	41	0.53	0.60	2.1	2.1	1.8	3.4	4.6	FD 02	3.5	9000	14000	4.0	6.3	FA 02	3.5	14000	14000	4.0	6.1	BA 60	5	12000	5.4	6.9	
0.12	BN 63B	6	1.32	45	0.60	0.64	2.1	1.9	1.7	3.7	4.9	FD 02	3.5	9000	14000	4.3	6.6	FA 02	3.5	14000	14000	4.3	6.4	BA 60	5	12000	5.7	7.2	
0.18	BN 71A	6	1.91	56	0.69	0.67	2.6	1.9	1.7	8.4	5.5	FD 03	5.0	8100	13500	9.5	8.2	FA 03	5.0	13500	13500	9.5	7.9	BA 70	8	12300	10.4	9.4	
0.25	BN 71B	6	2.7	62	0.71	0.82	2.6	1.9	1.7	10.9	6.7	FD 03	5.0	7800	13000	12	9.4	FA 03	5.0	13000	13000	12	9.1	BA 70	8	12000	12.9	10.6	
0.37	BN 71C	6	3.9	66	0.69	1.17	3	2.4	2.0	12.9	7.7	FD 03	7.5	5100	9500	14	10.4	FA 03	7.5	9500	9500	14	10.1	BA 70	8	8900	14.9	11.6	
0.37	BN 80A	6	3.9	68	0.68	1.15	3.2	2.2	2.0	21	9.9	FD 04	10	5200	8500	23	13.8	FA 04	10	8500	8500	23	13.7	BA 80	18	8000	24	15.2	
0.55	BN 80B	6	5.7	70	0.69	1.64	3.9	2.6	2.2	25	11.3	FD 04	15	4800	7200	27	15.2	FA 04	15	7200	7200	27	15.1	BA 80	18	6800	28	16.6	
0.75	BN 80C	6	7.8	70	0.65	2.38	3.8	2.5	2.2	28	12.2	FD 04	15	3400	6400	30	16.1	FA 04	15	6400	6400	30	16.0	BA 80	18	6100	31	17.5	
0.75	BN 90S	6	7.8	69	0.68	2.31	3.8	2.4	2.2	26	12.6	FD 14	15	3400	6500	28	16.8	FA 14	15	6500	6500	28	16.7	BA 90	35	5500	33	19.9	
1.1	BN 90L	6	11.4	72	0.69	3.2	3.9	2.3	2.0	33	15	FD 05	26	2700	5000	37	21	FA 05	26	5000	5000	37	22	BA 90	35	4600	40	22	
1.5	BN 100LA	6	15.2	73	0.72	4.1	4	2.1	2.0	82	22	FD 15	40	1900	4100	86	28	FA 15	40	4100	4100	86	29	BA 100	50	3800	94	32	
1.85	BN 100LB	6	19.0	75	0.73	4.9	4.5	2.1	2.0	95	24	FD 15	40	1700	3600	99	30	FA 15	40	3600	3600	99	31	BA 100	50	3400	107	34	
2.2	BN 112M	6	22	78	0.73	5.6	4.8	2.2	2.0	168	32	FD 06S	60	—	2100	177	42	FA 06S	60	2100	2100	177	44	BA 110	75	2000	184	45	
3	BN 132S	6	30	76	0.76	7.5	4.8	1.9	1.8	216	36	FD 06	75	—	1400	226	49	FA 06	75	1400	1400	226	50	BA 140	150	1200	266	68	
4	BN 132MA	6	40	78	0.77	9.6	5.5	2.0	1.8	295	45	FD 06	100	—	1200	305	58	FA 07	100	1200	1200	318	63	BA 140	150	1050	345	77	
5.5	BN 132MB	6	56	80	0.78	12.7	5.9	2.1	1.9	383	56	FD 07	150	—	1050	406	72	FA 07	150	1050	1050	406	74	BA 140	150	1000	433	88	
7.5	BN 160M	6	75	84	0.81	15.9	5.9	2.2	2.0	740	83	FD 08	170	—	900	815	112	FA 08	170	900	900	815	113						
11	BN 160L	6	109	87	0.81	22.5	6.5	2.5	2.3	970	103	FD 08	200	—	800	1045	133	FA 08	200	800	800	1045	133						
15	BN 180L	6	148	88	0.82	30	6.2	2.0	2.4	1550	130	FD 09	300	—	600	1750	170												
18.5	BN 200LA	6	184	88	0.81	37	5.9	2.0	2.3	1700	145	FD 09	400	—	450	1900	185												

8 P**750 min⁻¹ - S1****50 Hz**

Pn kW		n min ⁻¹	Mn Nm	η %	cos φ	In [400V] A	Is In	Ms Mn	Ma Mn	Jm x 10 ⁻⁴ kgm ²	IM B5 	freno c.c. / d.c. brake G.S.-bremse / frein c.c.						freno c.a. / a.c. brake W.S.-bremse / frein c.a.											
												FD			FA			BA			FD			FA			BA		
												Mod.	Mb Nm	Zo 1/h NB SB	Jm x 10 ⁻⁴ kgm ²	IM B5 	Mod.	Mb Nm	Zo 1/h	Jm x 10 ⁻⁴ kgm ²	IM B5 	Mod.	Mb max Nm	Zo 1/h	Jm x 10 ⁻⁴ kgm ²	IM B5 			
0.09	BN 71A	8	1.26	47	0.59	0.47	2.3	2.4	2.3	10.9	6.7	FD 03	3.5	9000	16000	12.0	9.4	FA 03	3.5	16000	12.0	9.1	BA 70	8.0	14000	12.9	10.6		
0.12	BN 71B	8	1.69	51	0.59	0.58	2.1	2.3	2.2	12.9	7.7	FD 03	5.0	9000	16000	14.0	10.4	FA 03	5.0	16000	14.0	10.1	BA 70	8.0	14000	14.9	11.6		
0.18	BN 80A	8	2.49	51	0.60	0.85	2.4	2.2	2.2	15	8.2	FD 04	5.0	6500	11000	16.6	12.1	FA 04	5.0	11000	16.6	12.0	BA 80	18.0	10000	—	—		
0.25	BN 80B	8	3.51	54	0.63	1.06	2.4	2.0	1.9	20	9.9	FD 04	10.0	6000	10000	22	13.8	FA 04	10.0	10000	23	13.7	BA 80	18.0	9500	24	15.2		
0.37	BN 90S	8	5.2	58	0.60	1.53	2.6	2.3	2.1	26	12.6	FD 14	15.0	4800	7500	28	16.8	FA 14	15.0	7500	28	16.7	BA 90	35	6800	33	19.9		
0.55	BN 90L	8	7.8	62	0.60	2.13	2.6	2.2	2.0	33	15	FD 05	26	4000	6400	37	21	FA 05	26	6400	37	22	BA 90	35	6000	40	22		
0.75	BN 100LA	8	10.2	68	0.63	2.53	3.4	1.9	1.7	82	22	FD 15	26	2800	4800	86	28	FA 15	26	4800	86	29	BA 100	50	4500	94	32		
1.1	BN 100LB	8	15.0	68	0.64	3.65	3.2	1.7	1.7	95	24	FD 15	40	2500	4000	99	30	FA 15	40	4000	99	31	BA 100	50	3700	107	34		
1.5	BN 112M	8	20.2	71	0.66	4.6	3.7	1.8	1.9	168	32	FD 06S	60	—	3000	177	42	FA 06S	60	3000	177	44	BA 110	75	2700	184	45		
2.2	BN 132S	8	29.6	75	0.66	6.4	3.8	1.8	2.0	295	45	FD 56	75	—	2300	305	58	FA 06	75	2300	305	56	BA 140	150	2000	345	77		
3	BN 132MA	8	40.4	76	0.69	8.3	3.9	1.6	1.8	370	53	FD 06	100	—	1900	394	69	FA 07	100	1900	406	74	BA 140	150	1700	433	88		

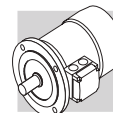

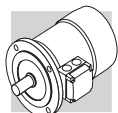











2/4 P

3000/1500 min⁻¹ - S1

50 Hz

Pn kW		n min ⁻¹	Mh Nm	η %	cos φ	In [400V] A	Is In	Ms Mn	Ma Mn	Jm x 10 ⁻⁴ kgm ²	IMB5 	freno c.c. / d.c. brake G.S.-bremse / frein c.c.						freno c.a. / a.c. brake W.S.-bremse / frein c.a.											
												FD			FA			BA			FD			FA			BA		
												Mod.	Mb Nm	Zo 1/h	Jm x 10 ⁻⁴ kgm ²	IMB5 	Mod.	Mb Nm	Zo 1/h	Jm x 10 ⁻⁴ kgm ²	IMB5 	Mod.	Mb Nm	Zo 1/h	Jm x 10 ⁻⁴ kgm ²	IMB5 			
0.20	BN 63B	2	0.71	55	0.82	0.64	3.5	2.1	1.9	2.9	4.4	FD 02	3.5	2200	2600	3.5	6.1	FA 02	3.5	2600	5100	3.5	5.9	BA 60	5	2000	49	6.7	
0.15		4	1.06	49	0.67	0.66	2.6	1.8	1.7	4.7	4.4		4000	5100											4000				
0.28	BN 71A	2	0.99	56	0.82	0.88	2.9	1.9	1.7	4.7	4.4	FD 03	3.5	2100	2400	5.8	7.1	FA 03	3.5	2400	4800	5.8	6.8	BA 70	8	2100	56	8.3	
0.20		4	1.39	59	0.72	0.68	3.1	1.8	1.7	5.8	5.1		3800	4800											4200				
0.37	BN 71B	2	1.29	56	0.82	1.16	3.5	1.8	1.8	5.8	5.1	FD 03	5	1400	2100	6.9	7.8	FA 03	5	2100	4200	6.9	7.5	BA 70	8	1800	7.8	9.0	
0.25		4	1.72	60	0.73	0.82	3.3	2.0	1.9	6.9	5.9		2900	4200											3600				
0.45	BN 71C	2	1.55	63	0.85	1.21	3.8	1.8	1.8	6.9	5.9	FD 03	5	1400	2100	8.0	8.6	FA 03	5	2100	4200	8.0	8.3	BA 70	8	1800	8.9	9.8	
0.30		4	2.0	63	0.73	0.94	3.6	2.0	1.9	15	8.2		2900	4200											3600				
0.55	BN 80A	2	1.9	63	0.85	1.48	3.9	1.7	1.7	15	8.2	FD 04	5	1600	2300	16.6	12.1	FA 04	5	2300	4000	16.6	12.0	BA 80	18	2100	18	13.5	
0.37		4	2.5	67	0.79	1.01	4.1	1.8	1.9	20	9.9		3000	4000											3700				
0.75	BN 80B	2	2.6	65	0.85	1.96	3.8	1.9	1.8	20	9.9	FD 04	10	1400	1600	22	13.8	FA 04	10	1600	3600	22	13.7	BA 80	18	1500	22	15.2	
0.55		4	3.8	68	0.81	1.44	3.9	1.7	1.7	20	9.9		2700	3600											3300				
1.1	BN 90S	2	3.8	71	0.82	2.73	4.7	2.3	2.0	21	12.2	FD 14	10	1500	1600	23	16.4	FA 14	10	1600	2800	23	16.3	BA 90	35	1300	28	19.5	
0.75		4	5.2	66	0.79	2.08	4.6	2.4	2.2	28	14.0		2300	2800											2300				
1.5	BN 90L	2	5.2	70	0.85	3.64	4.5	2.4	2.1	28	14.0	FD 05	26	1050	1200	32	20	FA 05	26	1200	2000	32	21	BA 90	35	1100	35	21	
1.1		4	7.6	73	0.81	2.69	4.7	2.5	2.2	28	14.0		1600	2000											1800				
2.2	BN 100LA	2	7.5	72	0.85	5.2	4.5	2.0	1.9	40	18.3	FD 15	26	600	900	44	25	FA 15	26	900	44	25	25	BA 100	50	750	51	29	
1.5		4	10.2	73	0.79	3.8	4.7	2.0	2.0	40	18.3		1300	2300											1900				
3.5	BN 100LB	2	11.7	80	0.84	7.5	5.4	2.2	2.1	61	25	FD 15	40	500	900	65	31	FA 15	40	900	65	32	32	BA 100	50	750	72	35	
2.5		4	16.8	82	0.80	5.5	5.2	2.2	2.2	98	30		1000	2100											1800				
4	BN 112M	2	13.3	79	0.83	8.8	6.1	2.4	2.0	98	30	FD 06S	60	—	700	107	40	40	FA 06S	60	700	107	42	42	BA 110	75	600	114	43
3.3		4	22.2	80	0.80	7.4	5.1	2.1	2.0	213	44		—	1200	—	—	—	—	—	—	—	—	—	—	1100				
5.5	BN 132S	2	18.2	80	0.87	11.4	5.9	2.4	2.0	213	44	FD 06	75	—	350	223	57	57	FA 06	75	350	223	58	58	BA 140	150	300	263	76
4.4		4	29	82	0.84	9.2	5.3	2.2	2.0	270	53		—	900	—	—	—	—	—	—	—	—	—	—	750				
7.5	BN 132MA	2	25	82	0.87	15.2	6.5	2.4	2.0	270	53	FD 06	100	—	350	280	66	66	FA 07	100	350	293	71	71	BA 140	150	300	320	85
6		4	40	84	0.85	12.1	5.8	2.3	2.1	319	59		—	900	—	—	—	—	—	—	—	—	—	—	—	800			
9.2	BN 132MB	2	30	83	0.86	18.6	6.0	2.6	2.2	319	59	FD 07	150	—	300	342	75	75	FA 07	150	300	342	77	77	BA 140	150	300	369	91
7.3		4	48	85	0.85	14.6	5.5	2.3	2.1	319	59		—	800	—	—	—	—	—	—	—	—	—	—	750				

Pn kW		n min ⁻¹	Mh Nm	η %	cos φ	In [400V] A	Is In	Ms Mn	Ma Mn	Jm x 10 ⁻⁴ kgm ²	IMB5 	freno c.c. / d.c. brake G.S.-bremse / frein c.c.						freno c.a. / a.c. brake W.S.-bremse / frein c.a.											
												FD			FA			BA			FD			FA			BA		
												Mod.	Mb Nm	Zo 1/h NB SB	Jm x 10 ⁻⁴ kgm ²	IMB5 	Mod.	Mb Nm	Zo 1/h	Jm x 10 ⁻⁴ kgm ²	IMB5 	Mod.	Mb Nm	Zo 1/h	Jm x 10 ⁻⁴ kgm ²	IMB5 			
0.25	BN 71A	2	0.84	60	0.82	0.73	4.3	1.9	1.8	6.9	5.9	FD 03	1.75	1500	1700	8.0	8.6	FA 03	2.5	1700	13000	8.0	8.3	BA 70	8	1500	8.9	9.8	
0.08		6	0.84	43	0.70	0.38	2.1	1.4	1.5				10000	13000															
0.37	BN 71B	2	1.23	62	0.80	1.08	4.4	1.9	1.8	9.1	7.3	FD 03	3.5	1000	1300	10.2	10.0	FA 03	3.5	1300	11000	10.2	9.7	BA 70	8	1200	11.1	11.2	
0.12		6	1.27	44	0.73	0.54	2.4	1.4	1.5				9000	11000															
0.55	BN 80A	2	1.88	63	0.86	1.47	4.5	1.9	1.7	20	9.9	FD 04	5	1500	1800	22	13.8	FA 04	5	1800	6300	22	13.7	BA 80	18	1700	23	15.2	
0.18		6	1.85	52	0.65	0.77	3.3	2	1.9				4100	6300															
0.75	BN 80B	2	2.6	66	0.87	1.89	4.3	1.8	1.6	25	11.3	FD 04	5	1700	1900	27	15.2	FA 04	5	1900	6000	27	15.1	BA 80	18	1800	28	16.6	
0.25		6	2.6	54	0.67	1.00	3.2	1.7	1.8				3800	6000															
1.1	BN 90L	2	3.7	67	0.84	2.82	4.7	2.1	1.9	28	14.0	FD 05	13	1400	1600	32	20	FA 05	13	1600	5200	32	21	BA 90	35	1500	35	21	
0.37		6	3.8	59	0.71	1.27	3.3	1.6	1.6				3400	5200															
1.5	BN 100LA	2	5.0	73	0.84	3.53	5.1	1.9	2.0	40	18.3	FD 15	13	1000	1200	44	24	FA 15	13	1200	4000	44	25	BA 100	50	1050	51	29	
0.55		6	5.6	64	0.67	1.85	3.5	1.7	1.8				2900	4000															
2.2	BN 100LB	2	7.2	77	0.85	4.9	5.9	2.0	2.0	61	25	FD 15	26	700	900	65	31	FA 15	26	900	3000	65	32	BA 100	50	800	72	36	
0.75		6	7.5	67	0.64	2.5	3.3	1.9	1.8				2100	3000															
3	BN 112M	2	9.9	78	0.87	6.4	6.3	2.0	2.1	98	30	FD 06S	40	—	1000	107	40	FA 06S	40	1000	2600	107	32	BA 110	75	930	114	43	
1.1		6	11.1	72	0.64	3.4	3.9	1.8	1.8				—	2600															
4.5	BN 132S	2	14.8	78	0.84	9.9	5.8	1.9	1.8	213	44	FD 56	37	—	500	223	57	FA 06	37	500	2100	223	58	BA 140	150	400	263	76	
1.5		6	14.9	74	0.67	4.4	4.2	1.9	2.0				—	2100															
5.5	BN 132M	2	18.0	78	0.87	11.7	6.2	2.1	1.9	270	53	FD 56	50	—	400	280	66	FA 06	50	400	1900	280	67	BA 140	150	350	320	85	
2.2		6	22	77	0.71	5.8	4.3	2.1	2.0				—	1900															

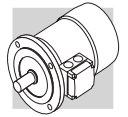

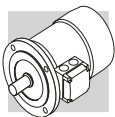





2/8 P

3000/750 min⁻¹ - S3 60/40%





50 Hz

Pn kW		n min ⁻¹	Mh Nm	η %	cos φ	In [400V] A	Is In	Ms Mn	Ma Mn	Jm x 10 ⁻⁴ kgm ²	IMB5 	freno c.c. / d.c. brake G.S.-bremse / frein c.c.						freno c.a. / a.c. brake W.S.-bremse / frein c.a.											
												FD			FA			BA			FD			FA			BA		
												Mod.	Mb Nm	Zo 1/h NB SB	Jm x 10 ⁻⁴ kgm ²	IMB5 	Mod.	Mb Nm	Zo 1/h	Jm x 10 ⁻⁴ kgm ²	IMB5 	Mod.	Mb Nm	Zo 1/h	Jm x 10 ⁻⁴ kgm ²	IMB5 			
0.25	BN 71A	2	0.86	61	0.87	0.68	3.9	1.8	1.9	10.9	6.7	FD 03	1.75	1300	1400	12	9.4	FA 03	2.5	1400	12	9.1	BA 70	8	1300	12.9	10.6		
0.06		8	0.84	31	0.61	0.46	2	1.8	1.9				10000	13000					13000						12000				
0.37	BN 71B	2	1.26	63	0.86	0.99	3.9	1.8	1.9	12.9	7.7	FD 03	3.5	1200	1300	14	10.4	FA 03	3.5	1300	14	10.1	BA 70	8	1200	14.9	11.6		
0.09		8	1.28	34	0.75	0.51	1.8	1.4	1.5				9500	13000					13000						12000				
0.55	BN 80A	2	1.86	66	0.86	1.40	4.4	2.1	2.0	20	9.9	FD 04	5	1500	1800	22	13.8	FA 04	5	1800	22	13.7	BA 80	18	1700	23	15.2		
0.13		8	1.80	41	0.64	0.72	2.3	1.6	1.7				5600	8000					8000						7500				
0.75	BN 80B	2	2.6	68	0.88	1.81	4.6	2.1	2.0	25	11.3	FD 04	10	1700	1900	27	15.2	FA 04	10	1900	27	15.1	BA 80	18	1800	28	16.6		
0.18		8	2.5	43	0.66	0.92	2.3	1.6	1.7				4800	7300					7300						7000				
1.1	BN 90L	2	3.7	63	0.84	3.00	4.5	2.1	1.9	28	14	FD 05	13	1400	1600	32	20	FA 05	13	1600	32	21	BA 90	35	1400	35	21		
0.28		8	3.9	48	0.63	1.34	2.4	1.8	1.9				3400	5100					5100						4500				
1.5	BN 100LA	2	5.0	69	0.85	3.69	4.7	1.9	1.8	40	18.3	FD 15	13	1000	1200	44	25	FA 15	13	1200	44	25	BA 100	50	1000	52	29		
0.37		8	5.1	46	0.63	1.84	2.1	1.6	1.6				3300	5000					5000						4200				
2.4	BN 100LB	2	7.9	75	0.82	5.6	5.4	2.1	2.0	61	25	FD 15	26	550	700	65	31	FA 15	26	700	65	32	BA 100	50	600	72	36		
0.55		8	7.5	54	0.58	2.5	2.6	1.8	1.8				2000	3500					3500						3100				
3	BN 112M	2	9.9	76	0.87	6.5	6.3	2.1	1.9	98	30	FD 06S	40	—	900	107	40	FA 06S	40	900	107	42	BA 110	75	800	114	43		
0.75		8	10.4	60	0.65	2.8	2.5	1.6	1.6				—	2900					2900						2700				
4	BN 132S	2	13.3	73	0.84	9.4	5.6	2.3	2.4	213	44	FD 56	37	—	500	223	57	FA 06	37	500	223	58	BA 140	150	400	263	76		
1		8	13.8	66	0.62	3.5	2.9	1.9	1.8				—	3500					3500						3000				
5.5	BN 132M	2	18.3	75	0.84	12.6	6.1	2.4	2.5	270	53	FD 06	50	—	400	280	66	FA 06	50	400	280	67	BA 140	150	350	320	85		
1.5		8	21	68	0.63	5.1	2.9	1.9	1.9				—	2400					2400						2100				

2/12 P

3000/500 min⁻¹ - S3 60/40%

50 Hz



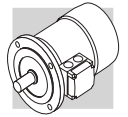

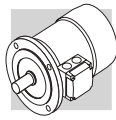
Pn kW		freno c.c. / d.c. brake G.S.-bremse / frein c.c.												freno c.a. / a.c. brake W.S.-bremse / frein c.a.																
		FD						FA						BA																
		Mod.	Mb Nm	Zo 1/h	NB SB	Jm x 10 ⁻⁴ kgm ²	IM B5 	Mod.	Mb Nm	Zo 1/h	Jm x 10 ⁻⁴ kgm ²	IM B5 	Mod.	Mb max Nm	Zo 1/h	Jm x 10 ⁻⁴ kgm ²	IM B5 													
0.55	BN 80B	2	1.86	64	0.89	4.2	1.39	4.2	1.6	1.7	25	11.3	FD 04	5	1000	1300	27	15.2	FA 04	5	1300	1300	27	15.1	BA 80	18	1200	28	16.6	
0.09		12	2.0	30	0.63	1.8	0.69	1.8	1.9	1.8			8000	12000																
0.75	BN 90L	2	2.6	56	0.89	4.2	2.17	4.2	1.8	1.7	26	12.6	FD 05	13	1000	1150	30	18.6	FA 05	13	1150	1150	30	19.3	BA 90	35	1050	33	19.9	
0.12		12	2.7	26	0.63	1.7	1.06	1.7	1.4	1.6			4600	6300																
1.1	BN 100LA	2	3.7	65	0.85	4.5	2.87	4.5	1.6	1.8	40	18.3	FD 15	13	700	900	44	25	FA 15	13	900	900	44	25	BA 100	50	750	52	29	
0.18		12	4.0	26	0.54	1.5	1.85	1.5	1.3	1.5			4000	6000																
1.5	BN 100LB	2	4.9	67	0.86	5.6	3.76	5.6	1.9	1.9	54	22	FD 15	13	700	900	58	28	FA 15	13	900	900	58	29	BA 100	50	800	66	32	
0.25		12	5.4	36	0.46	1.8	2.18	1.8	1.7	1.8			3800	5000																
2	BN 112M	2	6.6	74	0.88	6.5	4.43	6.5	2.1	2	98	30	FD 06S	20	—	800	107	40	FA 06S	20	800	800	107	42	BA 110	75	750	114	43	
0.3		12	6.2	46	0.43	2	2.19	2	2.1	2			—	3400																
3	BN 132S	2	9.8	74	0.87	6.8	6.7	6.8	2.3	1.9	213	44	FD 56	37	—	450	223	57	FA 06	37	450	450	223	58	BA 140	150	380	263	76	
0.5		12	10.2	51	0.43	2	3.3	2	1.7	1.6			—	3000																
4	BN 132M	2	13.1	75	0.89	5.9	8.6	5.9	2.4	2.3	270	53	FD 56	37	—	400	280	66	FA 06	37	400	400	280	67	BA 140	150	350	320	85	
0.7		12	14.5	53	0.44	1.9	4.3	1.9	1.7	1.6			—	2800																





Pn kW		n min ⁻¹	Mn Nm	η %	cos φ	In [400V] A	Is In	Ms Mn	Ma Mn	Jm x 10 ⁻⁴ kgm ²	IM B5 	freno c.c. / d.c. brake G.S.-bremse / frein c.c.						freno c.a. / a.c. brake W.S.-bremse / frein c.a.												
												FD			FA			BA			FA			BA						
												Mod.	Mb Nm	Zo 1/h	Mod.	Mb Nm	Zo 1/h	Mod.	Mb Nm	Zo 1/h	Mod.	Mb Nm	Zo 1/h	Mod.	Mb Nm	Zo 1/h	Mod.	Mb Nm	Zo 1/h	
0.22	BN 71B	4	1.5	64	0.74	0.67	3.9	1.8	1.9	9.1	7.3	IM B5	FD 03	3.5	2500	3500	10.2	10	FA 03	3.5	3500	9000	10.2	9.7	BA 70	8	3200	8200	11.1	11.2
0.13		6	1.4	43	0.67	0.65	2.3	1.6	1.7					5000	9000															
0.30	BN 80A	4	2.0	61	0.82	0.87	3.5	1.3	1.5	15	8.2	IM B5	FD 04	5	2500	3100	16.6	12.1	FA 04	5	3100	6000	16.6	12.0	BA 80	18	2800	18	13.5	
0.20		6	2.1	54	0.66	0.81	3.2	1.9	2.0					4000	6000															
0.40	BN 80B	4	2.7	63	0.75	1.22	3.9	1.8	1.8	20	9.9	IM B5	FD 04	10	1800	2300	22	13.8	FA 04	10	2300	5500	22	13.7	BA 80	18	2200	23	15.2	
0.26		6	2.7	55	0.70	0.97	2.7	1.5	1.6					3600	5500															
0.55	BN 90S	4	3.7	70	0.78	1.45	4.5	2.0	1.9	21	12.2	IM B5	FD 14	10	1500	2100	23	16.1	FA 14	10	2100	4100	23	16.3	BA 90	35	1700	28	19.5	
0.33		6	3.4	62	0.70	1.10	3.7	2.3	2.0					2500	4100															
0.75	BN 90L	4	5.0	74	0.78	1.88	4.3	1.9	1.8	28	14	IM B5	FD 05	13	1400	2000	32	20	FA 05	13	2000	3600	32	21	BA 90	35	1800	35	21	
0.45		6	4.7	66	0.71	1.39	3.3	2.0	1.9					2300	3600															
1.1	BN 100LA	4	7.2	74	0.79	2.72	5.0	1.7	1.9	82	22	IM B5	FD 15	26	1400	2000	86	28	FA 15	26	2000	3300	86	29	BA 100	50	1800	94	32	
0.8		6	8.0	65	0.69	2.57	4.1	1.9	2.1					2100	3300															
1.5	BN 100LB	4	9.9	75	0.79	3.65	5.1	1.7	1.9	95	25	IM B5	FD 15	26	1300	1800	99	31	FA 15	26	1800	3000	99	32	BA 100	50	1600	107	34	
1.1		6	11.1	72	0.68	3.24	4.3	2.0	2.1					2000	3000															
2.3	BN 112M	4	15.2	75	0.78	5.7	5.2	1.8	1.9	168	32	IM B5	FD 06S	40	—	1600	177	42	FA 06S	40	1600	2400	177	44	BA 110	75	1500	184	45	
1.5		6	14.9	73	0.72	4.1	4.9	2.0	2.0					—	2400															
3.1	BN 132S	4	20	83	0.83	6.5	5.9	2.1	2.0	213	44	IM B5	FD 56	37	—	1200	223	57	FA 06	37	1200	1900	223	58	BA 140	150	1000	263	76	
2		6	20	77	0.75	4.9	4.5	2.1	2.1					—	1900															
4.2	BN 132MA	4	27	84	0.82	8.8	5.9	2.1	2.2	270	53	IM B5	FD 06	50	—	900	280	66	FA 06	50	900	1500	280	67	BA 140	150	800	320	85	
2.6		6	26	79	0.72	6.6	4.3	2.0	2.0					—	1500															

4/8 P**1500/750 min⁻¹ - S1****50 Hz**

Pn kW		n min ⁻¹	Mh Nm	η %	cos φ	In [400V] A	Is In	Ms Mn	Ma Mn	Jm x 10 ⁻⁴ kgm ²	IM B5 	freno c.c. / d.c. brake G.S.-bremse / frein c.c.				freno c.a. / a.c. brake W.S.-bremse / frein c.a.							
												FD		FA		BA		FA		BA			
												Mod.	Mb Nm	Zo 1/h	Jm x 10 ⁻⁴ kgm ²	IM B5 	Mod.	Mb Nm	Zo 1/h	Jm x 10 ⁻⁴ kgm ²	IM B5 	Mod.	Mb Nm
0.37	BN 80A	4	2.5	63	0.82	1.03	3.3	1.4	1.4	15	8.2	10	2300	3500	10	10	3500	16.6	12.0	18	3200	18	13.5
0.18		8	2.5	44	0.60	0.98	2.2	1.5	1.6			10	4500	7000			7000				6500		
0.55	BN 80B	4	3.8	65	0.86	1.42	3.8	1.7	1.6	20	9.9	10	2200	2900	10	10	2900	22	13.7	18	2500	23	15.2
0.30		8	4.3	49	0.65	1.36	2.3	1.7	1.8			10	4200	6500			6500				5600		
0.65	BN 90S	4	4.5	73	0.85	1.51	4.0	1.9	1.9	28	13.6	15	2300	2800	15	15	2800	30	17.7	35	2400	35	21
0.35		8	4.8	49	0.57	1.81	2.5	2.1	2.2			15	3500	6000			6000				5100		
0.9	BN 90L	4	6.3	73	0.87	2.05	3.8	1.8	1.8	30	15.1	26	1700	2100	26	26	2100	34	22	35	1900	37	22
0.5		8	7.1	57	0.62	2.04	2.4	2.1	2			26	2500	4200			4200				3800		
1.3	BN 100LA	4	8.7	72	0.83	3.14	4.3	1.7	1.8	82	22	40	1300	1700	40	40	1700	86	29	50	1500	94	32
0.7		8	9.6	58	0.64	2.72	2.8	1.8	1.8			40	2000	3400			3400				3100		
1.8	BN 100LB	4	12.1	69	0.87	4.3	4.2	1.6	1.7	95	25	40	1200	1700	40	40	1700	99	32	50	1500	107	34
0.9		8	12.3	62	0.63	3.3	3.2	1.7	1.8			40	1600	2600			2600				2400		
2.2	BN 112M	4	14.6	77	0.85	4.9	5.3	1.8	1.8	168	32	60	1200	1700	60	60	1200	177	43	75	1100	184	45
1.2		8	16.1	70	0.63	3.9	3.3	1.9	1.8			60	2000	3400			3400				1900		
3.6	BN 132S	4	24	80	0.82	7.9	6.5	2.1	1.9	295	45	75	1000	1400	75	75	1000	305	59	150	900	345	77
1.8		8	24	72	0.55	6.6	4.6	1.9	2			75	1400	2000			2000				1200		
4.6	BN 132M	4	30	81	0.83	9.9	6.5	2.2	1.9	383	56	100	1000	1300	100	100	1000	406	74	150	900	433	88
2.3		8	31	73	0.54	8.4	4.4	2.3	2			100	1300	1900			1900				1200		

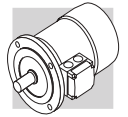

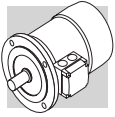

BN

IM B3

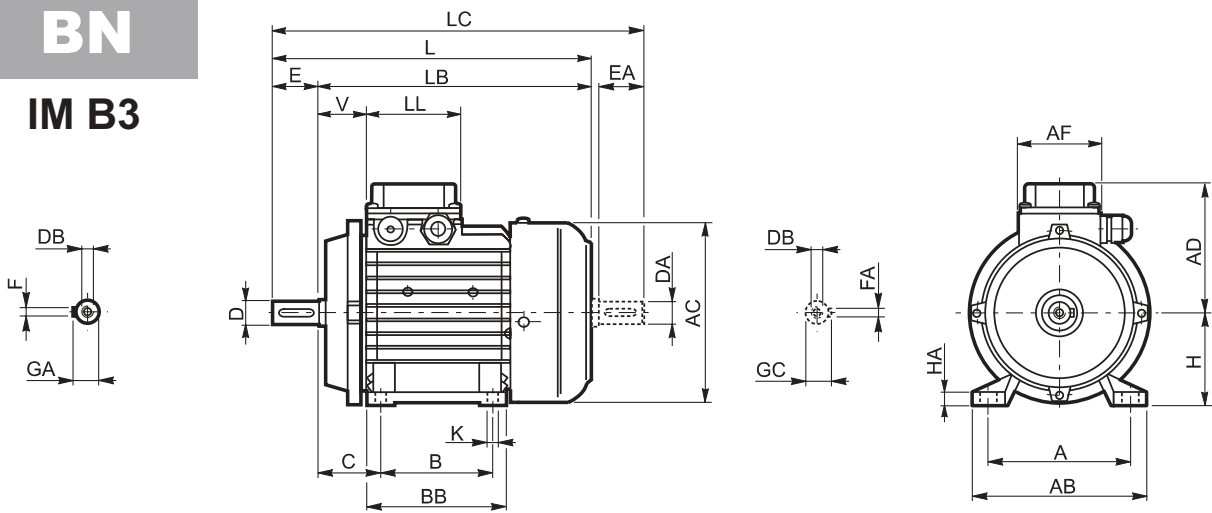

IM B5

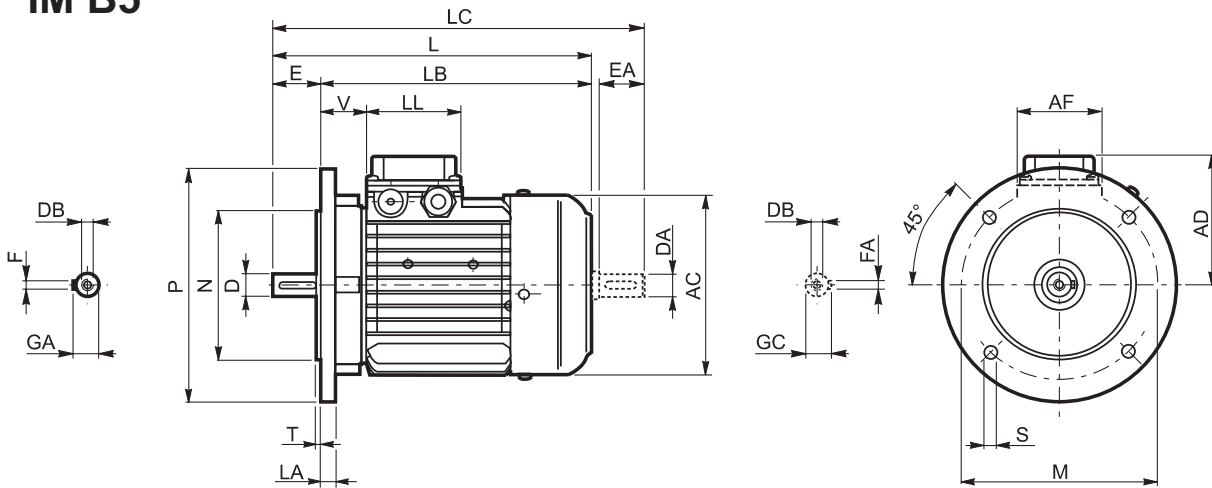

IM B14

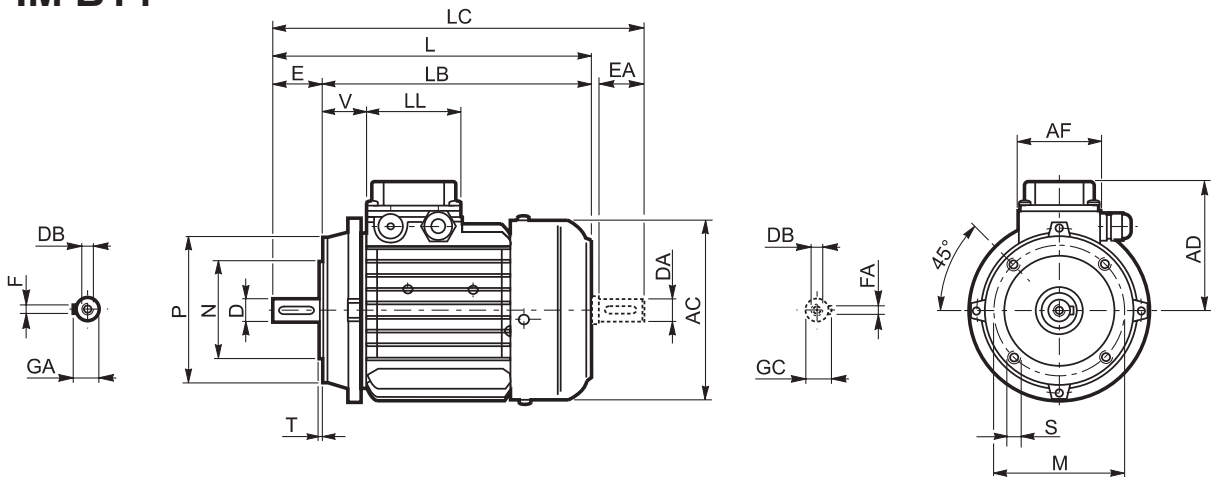

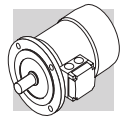
**M29 - DIMENSIONI****M29 - DIMENSIONS****M29 - ABMESSUNGEN****M29 - DIMENSIONS**

BN (IM B3)	Albero / Shaft / Welle / Arbre					Cassa / Frame / Gehäuse / Carcasse						Motore / Motor / Motor / Moteur									
	D DA	E EA	DB	GA GC	F FA	B	A	HA	BB	AB	K	C	H	AC	L	LB	LC	AD	AF	LL	V
BN 63	11	23	M4	12.5	4	80	100	7	96	120	7	40	63	121	212	189	237	92	74	80	30
BN 71	14	30	M5	16	5	90	112	8	112	135	7	45	71	138	249	219	281	105	74	80	35
BN 80	19	40	M6	21.5	6	100	125	9.5	124	153	10	50	80	156	273	233	315	115	74	80	38
BN 90S	24	50	M8	27	8	100	140	13	130	174	10	56	90	176	302	252	354	133	98	98	44
BN 90L	24	50	M8	27	8	125	140	13	155	174	10	56	90	176	326	276	379	133	98	98	44
BN 100	28	60	M10	31	8	140	160	14	175	192	12	63	100	195	366	306	429	142	98	98	50
BN 112	28	60	M10	31	8	140	190	14	175	224	12	70	112	219	385	325	448	157	98	98	52
BN 132S	38	80	M12	41	10	140	216	16	180	260	12	89	132	258	455	375	538	193	118	118	58
BN 132M	38	80	M12	41	10	178	216	16	218	260	12	89	132	258	493	413	576	193	118	118	58

BN (IM B5)	Albero / Shaft / Welle / Arbre					Flangia / Flange / Flansch / Bride						Motore / Motor / Motor / Moteur								
	D DA	E EA	DB	GA GC	F FA	M	N	P	S	T	LA	AC	L	LB	LC	AD	AF	LL	V	
BN 56	9	20	M3	10.2	3	100	80	120	7	3	8	110	185	165	207	91	74	80	34	
BN 63	11	23	M4	12.5	4	115	95	140	9.5	3	10	121	207	184	232	95	74	80	26	
BN 71	14	30	M5	16	5	130	110	160	9.5	3.5	10	138	249	219	281	108	74	80	37	
BN 80	19	40	M6	21.5	6	165	130	200	11.5	3.5	11.5	156	274	234	315	119	74	80	38	
BN 90	24	50	M8	27	8	165	130	200	11.5	3.5	11.5	176	326	276	378	133	98	98	44	
BN 100	28	60	M10	31	8	215	180	250	14	4	14	195	367	307	429	142	98	98	50	
BN 112	28	60	M10	31	8	215	180	250	14	4	15	219	385	325	448	157	98	98	52	
BN 132	38	80	M12	41	10	265	230	300	14	4	20	258	493	413	576	193	118	118	58	
BN 160MR	42 38 ⁽¹⁾	110 80 ⁽¹⁾	M16 M12 ⁽¹⁾	45 41 ⁽¹⁾	12 10 ⁽¹⁾	300	250	350	18.5	5	15	258	562	452	645	193	118	118	218	
BN 160M	42 38 ⁽¹⁾	110 80 ⁽¹⁾	M16 M12 ⁽¹⁾	45 41 ⁽¹⁾	12 10 ⁽¹⁾	300	250	350	18.5	5	15	310	596	486	680	245	187	187	51	
BN 160L	42 38 ⁽¹⁾	110 80 ⁽¹⁾	M16 M12 ⁽¹⁾	45 41 ⁽¹⁾	12 10 ⁽¹⁾	300	250	350	18.5	5	15	310	596	486	680	245	187	187	51	
BN 180M	48 38 ⁽¹⁾	110 80 ⁽¹⁾	M16 M12 ⁽¹⁾	51.5 41 ⁽¹⁾	14 10 ⁽¹⁾	300	250	350	18.5	5	15	310	640	530	724	245	187	187	51	
BN 180L	48 42 ⁽¹⁾	110 110 ⁽¹⁾	M16 M16 ⁽¹⁾	51.5 45 ⁽¹⁾	14 12 ⁽¹⁾	300	250	350	18.5	5	18	348	708	598	823	261	187	187	52	
BN 200L	55 42 ⁽¹⁾	110 110 ⁽¹⁾	M20 M16 ⁽¹⁾	59 45 ⁽¹⁾	16 12 ⁽¹⁾	350	300	400	18.5	5	18	348	722	612	837	261	187	187	66	

BN (IM B14)	Albero / Shaft / Welle / Arbre					Flangia / Flange / Flansch / Bride					Motore / Motor / Motor / Moteur								
	D DA	E EA	DB	GA GC	F FA	M	N	P	S	T	AC	L	LB	LC	AD	AF	LL	V	
BN 56	9	20	M3	10.2	3	65	50	80	M5	2.5	110	185	165	207	91	74	80	34	
BN 63	11	23	M4	12.5	4	75	60	90	M5	2.5	121	207	184	232	95	74	80	26	
BN 71	14	30	M5	16	5	85	70	105	M6	2.5	138	249	219	281	108	74	80	37	
BN 80	19	40	M6	21.5	6	100	80	120	M6	3	156	274	234	315	119	74	80	38	
BN 90	24	50	M8	27	8	115	95	140	M8	3	176	326	276	378	133	98	98	44	
BN 100	28	60	M10	31	8	130	110	160	M8	3.5	195	366	306	429	142	98	98	50	
BN 112	28	60	M10	31	8	130	110	160	M8	3.5	219	385	325	448	157	98	98	52	
BN 132	38	80	M12	41	10	165	130	200	M10	4	258	493	413	576	193	118	118	58	

N.B.:

1) Queste dimensioni sono riferite alla seconda estremità d'albero

NOTE:

1) These values refer to the rear shaft end.

HINWEIS:

1) Diese Maße betreffen das zweite Wellenende.

REMARQUE :

1) Ces dimensions se réfèrent à la deuxième extrémité de l'arbre.

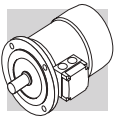

BN_FD

IM B3

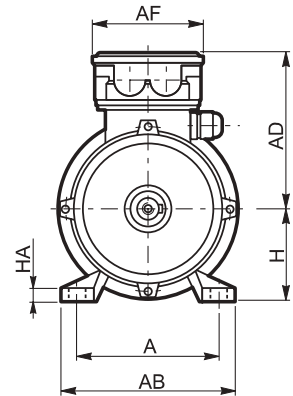
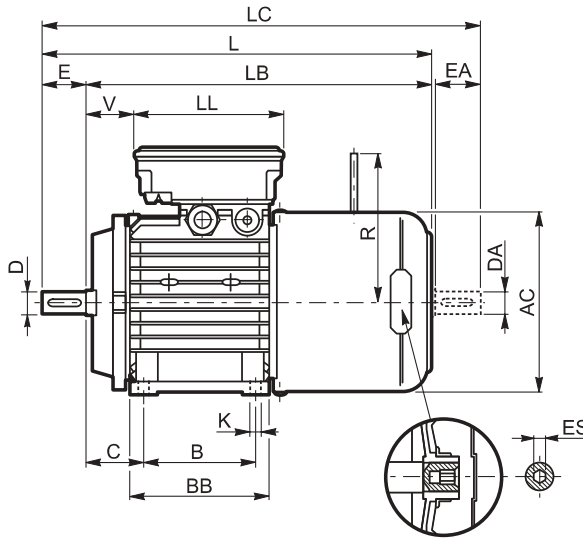
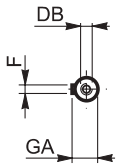

IM B5

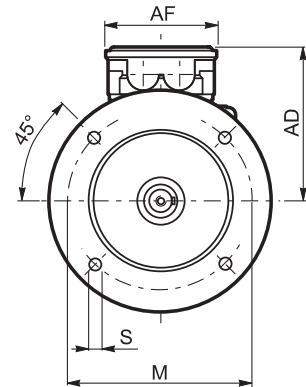
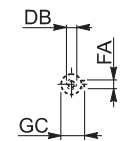
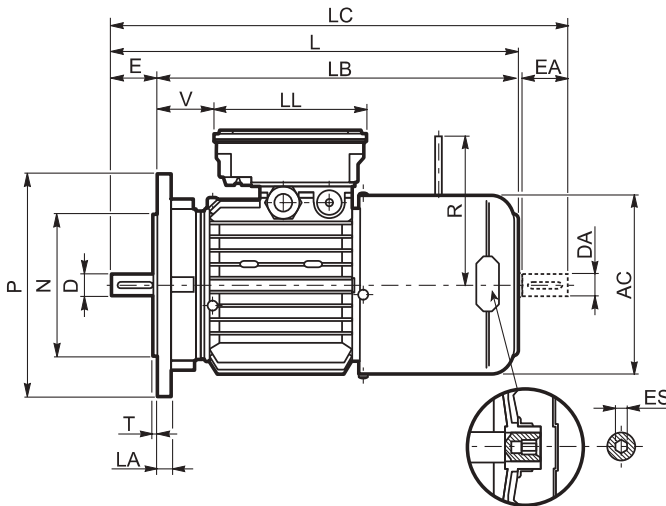
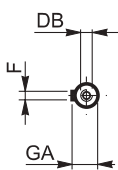

IM B14

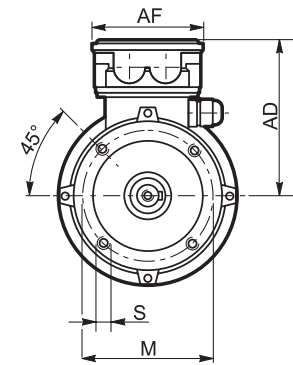
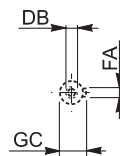
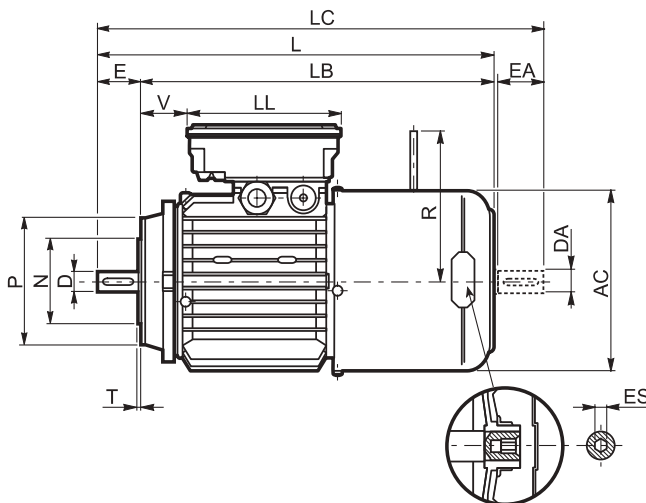
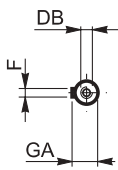

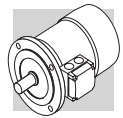

BN_FD (IM B3)	Albero / Shaft / Welle / Arbre					Cassa / Frame / Gehäuse / Carcasse							Motore / Motor / Motor / Moteur										
	D DA	E EA	DB	GA GC	F FA	B	A	HA	BB	AB	K	C	H	AC	L	LB	LC	AD	AF	LL	V	R	ES
BN 63	11	23	M4	12.5	4	80	100	7	96	120	7	40	63	121	269	246	294	119	98	133	51	96	5
BN 71	14	30	M5	16	5	90	112	8	112	135	7	45	71	138	310	280	342	132	98	133	25	103	5
BN 80	19	40	M6	21.5	6	100	125	9.5	124	153	10	50	80	156	346	306	388	143	98	133	41	129	5
BN 90S	24	50	M8	27	8	100	140	13	130	174	10	56	90	176	385	335	437	146	110	165	15	129	6
BN 90L	24	50	M8	27	8	125	140	13	155	174	10	56	90	176	409	359	461	146	110	165	39	160	6
BN 100	28	60	M10	31	8	140	160	14	175	192	12	63	100	195	458	398	521	155	110	165	62	160	6
BN 112	28	60	M10	31	8	140	190	14	175	224	12	70	112	219	484	424	547	170	110	165	73	199	6
BN 132S	38	80	M12	41	10	140	216	16	180	260	12	89	132	258	565	485	648	210	140	188	84	204 ⁽²⁾	6
BN 132M	38	80	M12	41	10	178	216	16	218	260	12	89	132	258	603	523	686	210	140	188	122	204 ⁽²⁾	6

BN_FD (IM B5)	Albero / Shaft / Welle / Arbre					Flangia / Flange / Flansch / Bride						Motore / Motor / Motor / Moteur									
	D DA	E EA	DB	GA GC	F FA	M	N	P	S	T	LA	AC	L	LB	LC	AD	AF	LL	V	R	ES
BN 63	11	23	M4	12.5	4	115	95	140	9.5	3	10	121	272	249	297	119	98	133	14	96	5
BN 71	14	30	M5	16	5	130	110	160	9.5	3.5	10	138	310	280	342	132	98	133	25	103	5
BN 80	19	40	M6	21.5	6	165	130	200	11.5	3.5	11.5	156	346	306	388	143	98	133	41	129	5
BN 90S	24	50	M8	27	8	165	130	200	11.5	3.5	11.5	176	409	359	461	146	110	165	39	129	6
BN 90L	24	50	M8	27	8	165	130	200	11.5	3.5	11.5	176	409	359	461	146	110	165	39	160	6
BN 100	28	60	M10	31	8	215	180	250	14	4	14	195	458	398	521	155	110	165	62	160	6
BN 112	28	60	M10	31	8	215	180	250	14	4	15	219	484	424	547	170	110	165	73	199	6
BN 132	38	80	M12	41	10	265	230	300	14	4	16	258	603	523	686	210	140	188	122	204 ⁽²⁾	6
BN 160MR	42 38 ⁽¹⁾	110 80 ⁽¹⁾	M16 M12 ⁽¹⁾	45 41 ⁽¹⁾	12 10 ⁽¹⁾	300	250	350	18.5	5	15	258	672	562	755	210	140	188	161	226	6
BN 160M	42 38 ⁽¹⁾	110 80 ⁽¹⁾	M16 M12 ⁽¹⁾	45 41 ⁽¹⁾	12 10 ⁽¹⁾	300	250	350	18.5	5	15	310	736	626	820	245	187	187	51	266	—
BN 160L	42 38 ⁽¹⁾	110 80 ⁽¹⁾	M16 M12 ⁽¹⁾	45 41 ⁽¹⁾	12 10 ⁽¹⁾	300	250	350	18.5	5	15	310	736	626	820	245	187	187	51	266	—
BN 180M	48 38 ⁽¹⁾	110 80 ⁽¹⁾	M16 M12 ⁽¹⁾	51.5 41 ⁽¹⁾	14 10 ⁽¹⁾	300	250	350	18.5	5	15	310	780	670	864	245	187	187	51	266	—
BN 180L	48 42 ⁽¹⁾	110 110 ⁽¹⁾	M16 M16 ⁽¹⁾	51.5 45 ⁽¹⁾	14 12 ⁽¹⁾	300	250	350	18.5	5	18	348	866	756	981	261	187	187	52	305	—
BN 200L	55 42 ⁽¹⁾	110 110 ⁽¹⁾	M20 M16 ⁽¹⁾	59 45 ⁽¹⁾	16 12 ⁽¹⁾	350	300	400	18.5	5	18	348	878	768	993	261	187	187	64	305	—

BN_FD (IM B14)	Albero / Shaft / Welle / Arbre					Flangia / Flange / Flansch / Bride					Motore / Motor / Motor / Moteur									
	D DA	E EA	DB	GA GC	F FA	M	N	P	S	T	AC	L	LB	LC	AD	AF	LL	V	R	ES
BN 63	11	23	M4	12.5	4	75	60	90	M5	2.5	121	272	249	297	119	98	133	14	96	5
BN 71	14	30	M5	16	5	85	70	105	M6	2.5	138	310	280	342	132	98	133	25	103	5
BN 80	19	40	M6	21.5	6	100	80	120	M6	3	156	346	306	388	143	98	133	41	129	5
BN 90S	24	50	M8	27	8	115	95	140	M8	3	176	409	359	461	146	110	165	39	129	6
BN 90L	24	50	M8	27	8	115	95	140	M8	3	176	409	359	461	146	110	165	39	160	6
BN 100	28	60	M10	31	8	130	110	160	M8	3.5	195	458	398	521	155	110	165	62	160	6
BN 112	28	60	M10	31	8	130	110	160	M8	3.5	219	484	424	547	170	110	165	73	199	6
BN 132	38	80	M12	41	10	165	130	200	M10	4	258	603	523	686	210	140	188	122	204 ⁽²⁾	6

N.B.:

- 1) Queste dimensioni sono riferite alla seconda estremità d'albero.
2) Per freno FD07 quota R=226

NOTE:

- 1) These values refer to the rear shaft end.
2) For FD07 brake value R=226

HINWEIS:

- 1) Diese Maße betreffen das zweite Wellenende
2) Für Bremse FD07, Maß R=226

REMARQUE :

- 1) Ces dimensions se réfèrent à la deuxième extrémité de l'arbre
2) Pour frein FD07 valeur R=226

L'esagono ES non è presente con l'opzione PS

ES hexagon is not supplied with PS option

Der Sechskant ES ist bei der Option PS nicht vorhanden.

L'hexagone ES n'est pas disponible avec l'option PS

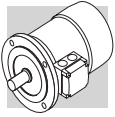

BN_FA

IM B3

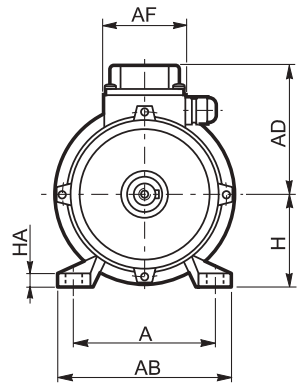
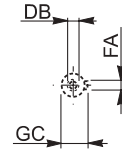
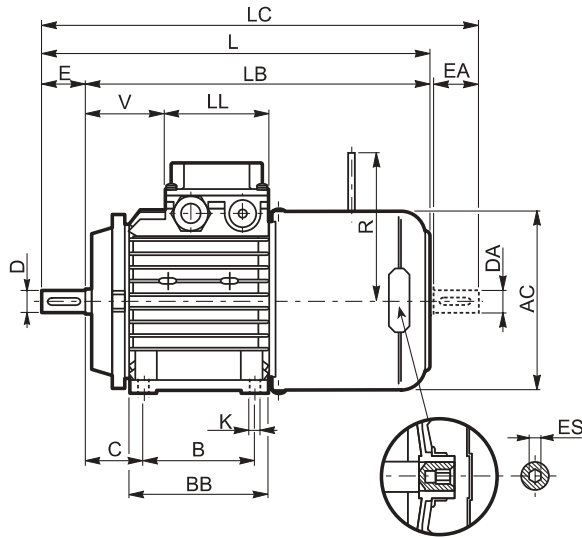
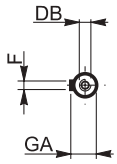

IM B5

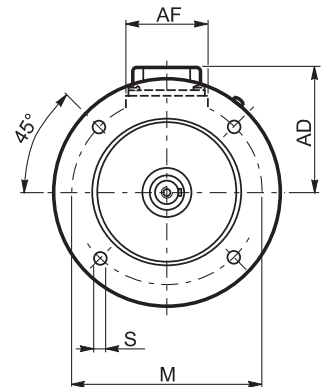
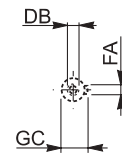
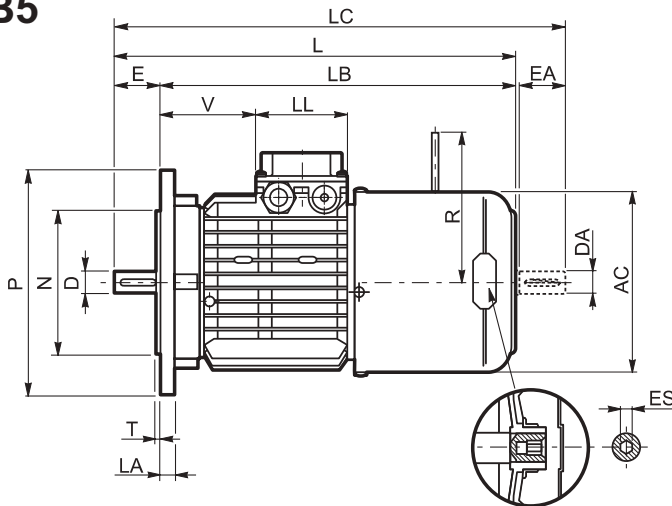
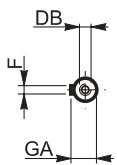

IM B14

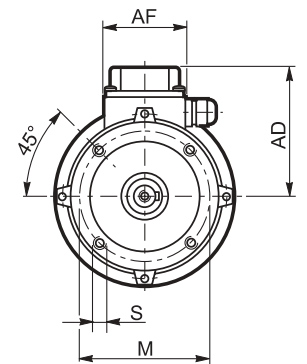
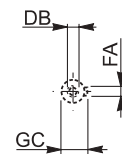
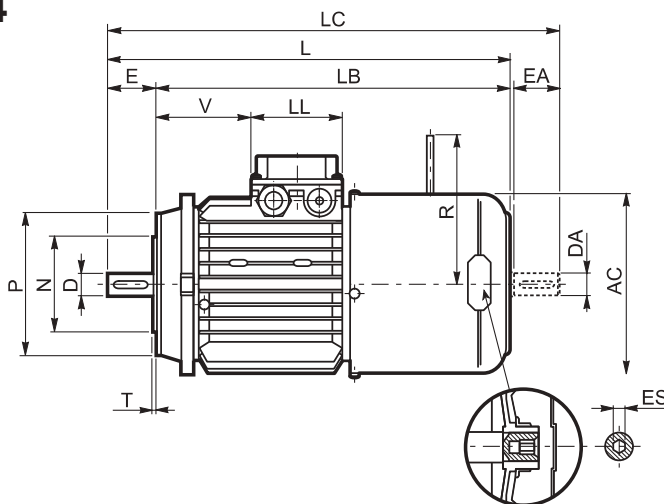
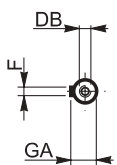

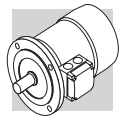

BN_FA (IM B3)	Albero / Shaft / Welle / Arbre					Cassa / Frame / Gehäuse / Carcasse						Motore / Motor / Motor / Moteur											
	D DA	E EA	DB	GA GC	F FA	B	A	HA	BB	AB	K	C	H	AC	L	LB	LC	AD	AF	LL	V	R	ES
BN 63	11	23	M4	12.5	4	80	100	7	96	120	7	40	63	121	269	246	294	92	74	80	51	116	5
BN 71	14	30	M5	16	5	90	112	8	112	135	7	45	71	138	310	280	342	105	74	80	68	124	5
BN 80	19	40	M6	21.5	6	100	125	9.5	124	153	10	50	80	156	346	306	388	115	74	80	83	134	5
BN 90S	24	50	M8	27	8	100	140	13	130	174	10	56	90	176	385	335	437	133	98	98	71	134	6
BN 90L	24	50	M8	27	8	125	140	13	155	174	10	56	90	176	409	359	461	133	98	98	95	160	6
BN 100	28	60	M10	31	8	140	160	14	175	192	12	63	100	195	458	398	521	142	98	98	119	160	6
BN 112	28	60	M10	31	8	140	190	14	175	224	12	70	112	219	484	424	547	157	98	98	142	198	6
BN 132S	38	80	M12	41	10	140	216	16	180	260	12	89	132	258	565	485	648	193	118	118	180	200 ⁽²⁾	6
BN 132M	38	80	M12	41	10	178	216	16	218	260	12	89	132	258	603	523	686	193	118	118	180	200 ⁽²⁾	6

BN_FA (IM B5)	Albero / Shaft / Welle / Arbre					Flangia / Flange / Flansch / Bride						Motore / Motor / Motor / Moteur									
	D DA	E EA	DB	GA GC	F FA	M	N	P	S	T	LA	AC	L	LB	LC	AD	AF	LL	V	R	ES
BN 63	11	23	M4	12.5	4	115	95	140	9.5	3	10	121	272	249	297	95	74	80	26	116	5
BN 71	14	30	M5	16	5	130	110	160	9.5	3.5	10	138	310	280	342	108	74	80	68	124	5
BN 80	19	40	M6	21.5	6	165	130	200	11.5	3.5	11.5	156	346	306	388	119	74	80	83	134	5
BN 90	24	50	M8	27	8	165	130	200	11.5	3.5	11.5	176	409	359	461	133	98	98	95	160	6
BN 100	28	60	M10	31	8	215	180	250	14	4	14	195	458	398	521	142	98	98	119	160	6
BN 112	28	60	M10	31	8	215	180	250	14	4	15	219	484	424	547	157	98	98	128	198	6
BN 132	38	80	M12	41	10	265	230	300	14	4	16	258	603	523	686	193	118	118	180	200 ⁽²⁾	6
BN 160MR	42 38 ⁽¹⁾	110 80 ⁽¹⁾	M16 M12 ⁽¹⁾	45 41 ⁽¹⁾	12 10 ⁽¹⁾	300	250	350	18.5	5	15	258	672	562	755	193	118	118	218	217	6
BN 160M	42 38 ⁽¹⁾	110 80 ⁽¹⁾	M16 M12 ⁽¹⁾	45 41 ⁽¹⁾	12 10 ⁽¹⁾	300	250	350	18.5	5	15	310	736	626	820	245	187	187	51	247	—
BN 160L	42 38 ⁽¹⁾	110 80 ⁽¹⁾	M16 M12 ⁽¹⁾	45 41 ⁽¹⁾	12 10 ⁽¹⁾	300	250	350	18.5	5	15	310	736	626	820	245	187	187	51	247	—
BN 180M	48 38 ⁽¹⁾	110 80 ⁽¹⁾	M16 M12 ⁽¹⁾	51.5 41 ⁽¹⁾	14 10 ⁽¹⁾	300	250	350	18.5	5	15	310	780	670	864	245	187	187	51	247	—

BN_FA (IM B14)	Albero / Shaft / Welle / Arbre					Flangia / Flange / Flansch / Bride					Motore / Motor / Motor / Moteur									
	D DA	E EA	DB	GA GC	F FA	M	N	P	S	T	AC	L	LB	LC	AD	AF	LL	V	R	ES
BN 63	11	23	M4	12.5	4	75	60	90	M5	2.5	121	272	249	119	95	74	80	26	116	5
BN 71	14	30	M5	16	5	85	70	105	M6	2.5	138	310	280	342	108	74	80	68	124	5
BN 80	19	40	M6	21.5	6	100	80	120	M6	3	156	346	306	388	119	74	80	83	134	5
BN 90	24	50	M8	27	8	115	95	140	M8	3	176	409	359	461	133	98	98	95	160	6
BN 100	28	60	M10	31	8	130	110	160	M8	3.5	195	458	398	521	142	98	98	119	160	6
BN 112	28	60	M10	31	8	130	110	160	M8	3.5	219	484	424	547	157	98	98	128	198	6
BN 132	38	80	M12	41	10	165	130	200	M10	4	258	603	523	686	193	118	118	180	200 ⁽²⁾	6

N.B.:

1) Queste dimensioni sono riferite alla seconda estremità d'albero.

2) Per freno FD07 quota R=226
Le dimensioni AD, AF, LL e V relative alla scatola morsettiera dei motori BN...FA dotati di alimentazione separata del freno (opzione SA) coincidono con quelle dei motori BN...FD di pari taglia.

L'esagono ES non è presente con l'opzione PS.

NOTE:

1) These values refer to the rear shaft end.

2) For FD07 brake value R=226
FDimensions AD, AF, LL and V, relevant to terminal box of motors BN...FA featuring the separate brake supply (option SA), are coincident with corresponding dimensions of same-size BN...FD motors.

ES hexagon is not supplied with PS option.

HINWEIS:

1) Diese Maße betreffen das zweite Wellenende

2) Für Bremse FD07, Maß R=226
Die Abmessungen des Klemmenkastens der Motoren BN ... FA AD, AF, LL und V in bezug auf die separate Spannungsversorgung (Option SA) stimmen mit den Abmessungen der entsprechenden Motoren BN...FD überein.

Der Sechskant ES ist bei der Option PS nicht vorhanden.

REMARQUE :

1) Ces dimensions se réfèrent à la deuxième extrémité de l'arbre

2) Pour frein FD07 valeur R=226
Les dimensions AD, AF, LL et V relatives à la boîte à borne des moteurs BN...FA équipés d'alimentation séparée du frein (option SA) sont identiques à celles des moteurs BN...FD de la même taille.

L'hexagone ES n'est pas disponible avec l'option PS.

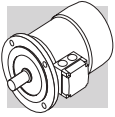

BN_BA

IM B3

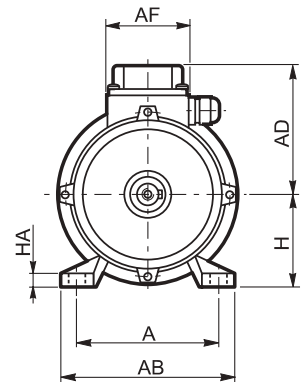
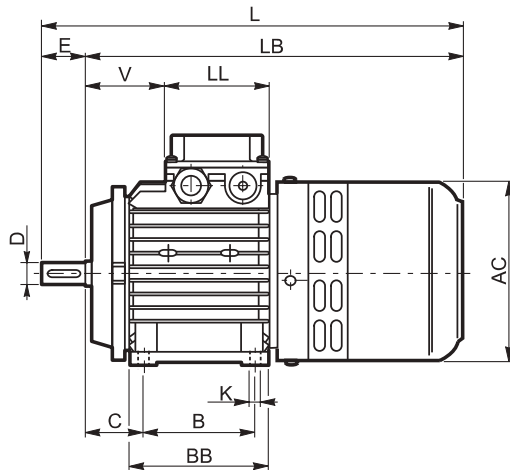
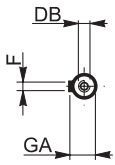

IM B5

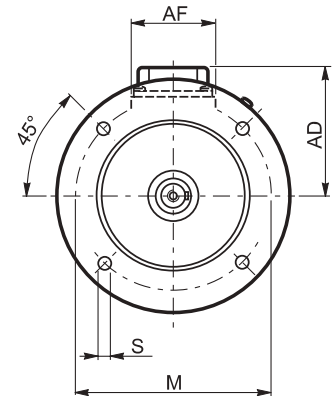
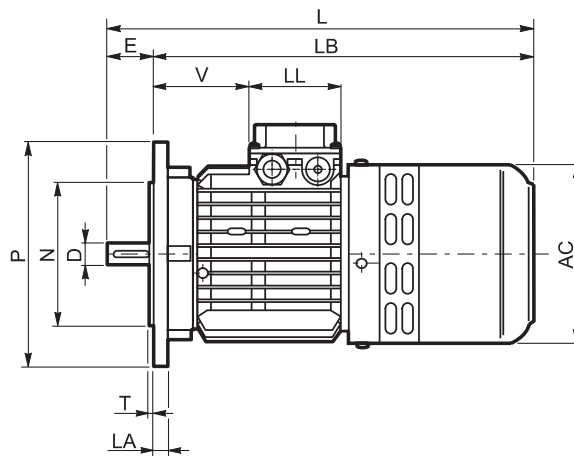
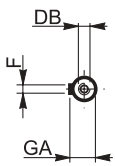

IM B14

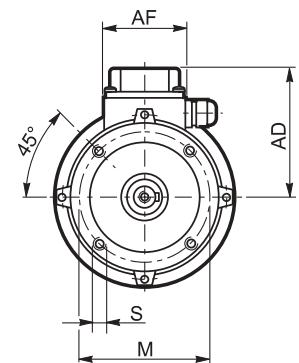
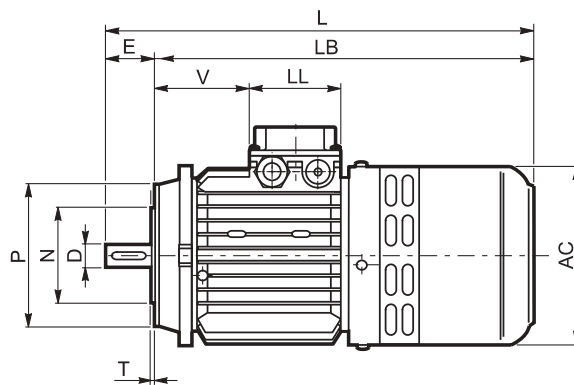
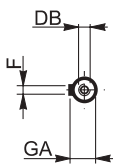

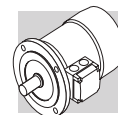

BN_BA (IM B3)	Albero / Shaft / Welle / Arbre					Cassa / Frame / Gehäuse / Carcasse						Motore / Motor / Motor / Moteur									
	D DA	E EA	DB	GA GC	F FA	B	A	HA	BB	AB	K	C	H	AC	L	LB	LC	AD	AF	LL	V
BN 71	14	30	M5	16	5	90	112	8	112	135	7	45	71	138	327	298	342	108	74	80	68
BN 80	19	40	M6	21.5	6	100	125	9.5	124	153	10	50	80	156	372	332	388	119	74	80	83
BN 90S	24	50	M8	27	8	100	140	13	130	174	10	56	90	176	400	350	437	133	98	98	71
BN 90L	24	50	M8	27	8	125	140	13	155	174	10	56	90	176	425	375	461	133	98	98	95
BN 100	28	60	M10	31	8	140	160	14	175	192	12	63	100	195	477	417	521	142	98	98	119
BN 112	28	60	M10	31	8	140	190	14	175	224	12	70	112	219	500	440	547	157	98	98	128
BN 132S	38	80	M12	41	10	140	216	16	180	260	12	89	132	258	600	520	648	193	118	118	142
BN 132M	38	80	M12	41	10	178	216	16	218	260	12	89	132	258	638	558	686	193	118	118	180

BN_BA (IM B5)	Albero / Shaft / Welle / Arbre					Flangia / Flange / Flansch / Bride						Motore / Motor / Motor / Moteur							
	D DA	E EA	DB	GA GC	F FA	M	N	P	S	T	LA	AC	L	LB	AD	AF	LL	V	
BN63	11	23	M4	12.5	4	115	95	140	9.5	3	10	124	298	275	95	74	80	28	
BN 71	14	30	M5	16	5	130	110	160	9.5	3.5	10	138	327	297	108	74	80	68	
BN 80	19	40	M6	21.5	6	165	130	200	11.5	3.5	11.5	156	372	332	119	74	80	83	
BN 90	24	50	M8	27	8	165	130	200	11.5	3.5	11.5	176	425	375	133	98	98	95	
BN 100	28	60	M10	31	8	215	180	250	14	4	14	195	477	417	142	98	98	119	
BN 112	28	60	M10	31	8	215	180	250	14	4	15	219	500	440	157	98	98	128	
BN 132	38	80	M12	41	10	265	230	300	14	4	16	258	638	558	193	118	118	180	

BN_BA (IM B14)	Albero / Shaft / Welle / Arbre					Flangia / Flange / Flansch / Bride					Motore / Motor / Motor / Moteur							
	D DA	E EA	DB	GA GC	F FA	M	N	P	S	T	AC	L	LB	AD	AF	LL	V	
BN 63	11	23	M4	12.5	4	75	60	90	M5	2.5	124	298	275	95	74	80	28	
BN 71	14	30	M5	16	5	85	70	105	M6	2.5	138	327	297	108	74	80	68	
BN 80	19	40	M6	21.5	6	100	80	120	M6	3	156	372	332	119	74	80	83	
BN 90	24	50	M8	27	8	115	95	140	M8	3	176	425	375	133	98	98	95	
BN 100	28	60	M10	31	8	130	110	160	M8	3.5	195	477	417	142	98	98	119	
BN 112	28	60	M10	31	8	130	110	160	M8	3.5	219	500	440	157	98	98	128	
BN 132	38	80	M12	41	10	165	130	200	M10	4	258	638	558	193	118	118	180	

N.B.:

Le dimensioni AD, AF, LL e V relative alla scatola morsettiera dei motori BN...BA dotati di alimentazione separata del freno (opzione SA) coincidono con quelle dei motori BN...FD di pari taglia.

NOTE:

Dimensions AD, AF, LL and V, relevant to terminal box of motors BN...BA featuring the separate brake supply (option SA), are coincident with corresponding dimensions of same-size BN...FD motors

HINWEIS:

Die Abmessungen des Klemmenkastens der Motoren BN ... BA AD, AF, LL und V in bezug auf die separate Spannungsversorgung (Option SA) stimmen mit den Abmessungen der entsprechenden Motoren BN...FD überein.

REMARQUE :

Les dimensions AD, AF, LL et V relatives à la boîte à borne des moteurs BN...BA équipés d'alimentation séparée du frein (option SA) sont identiques à celles des moteurs BN...FD de la même taille.

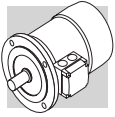

U1

BN, BN_FD, BN_FA

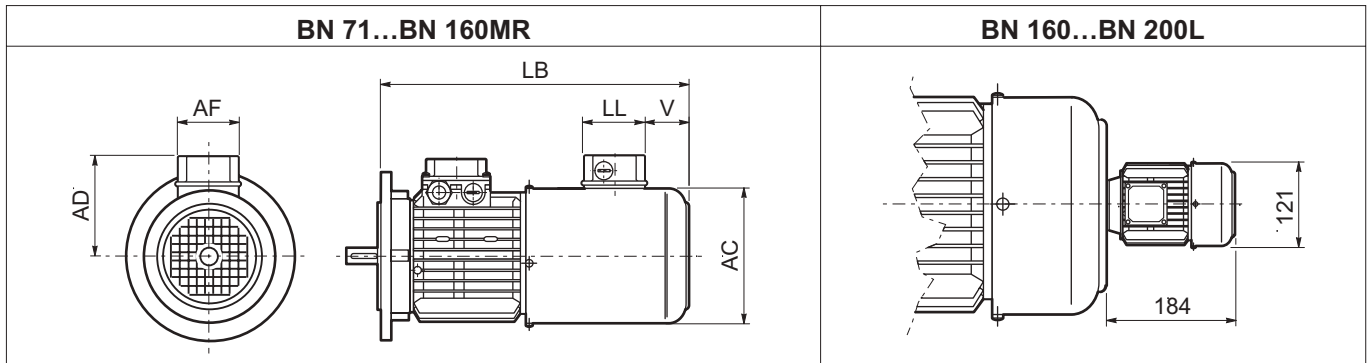

	LB	AC	AD	AF	LL	V
BN 71	312	138	112	70	70	36
BN 80	361	156	120	70	70	40
BN 90	407	176	131	70	70	45
BN 100	426	195	145	90	90	40
BN 112	455	219	155	70	70	55
BN 132	574	258	174	70	70	87
BN 160MR	613	258	174	70	70	87

U2

BN, BN_FD, BN_FA

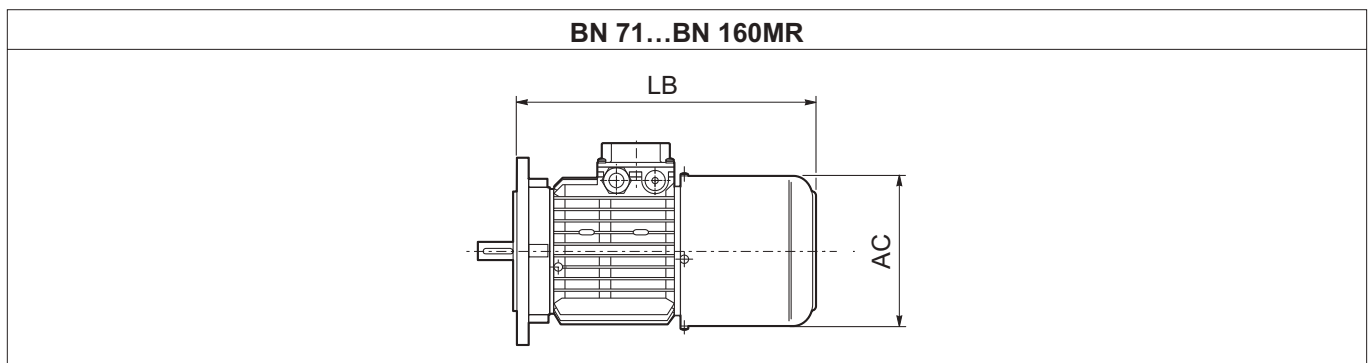

	LB	AC
BN 71	312	138
BN 80	361	156
BN 90S	407	176
BN 100	426	195
BN 112	455	219
BN 132	574	258
BN 160MR	613	258

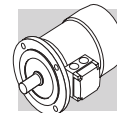

BONFIGLIOLI RIDUTTORI S.p.A.

Via Giovanni XXIII, 7/a
40012 Lippo di Calderara di Reno
Bologna (Italy)

Tel. +39 051 6473111
Fax +39 051 6473126
bonfiglioli@bonfiglioli.com
www.bonfiglioli.com

Company Certified UNI EN ISO 9001:2000



Bologna, 20/06/2008

**DICHIARAZIONE DI CONFORMITÀ RoHS
DECLARATION OF CONFORMITY RoHS
KONFORMITÄTSERKLÄRUNG RoHS
DECLARATION DE CONFORMITE RoHS**

Si dichiara che i prodotti elencati in questo catalogo sono costruiti secondo i requisiti della Direttiva 2002/95 CE con particolare riferimento alla limitazione delle seguenti sostanze pericolose:

We hereby declare that products listed in this catalogue are manufactured as per the requirements of Directive 2002/95 EC with reference to the restriction of the following hazardous substances:

Hiermit erklären wir, dass die Produkte, die in diesem Katalog aufgeführt werden, in Übereinstimmung mit den Anforderung der Richtlinie 2002/95/EG gefertigt werden bezogen auf die Restriktion der folgenden gefährlichen Substanzen:





Nous certifions que les produits présentés dans ce catalogue sont fabriqués selon les conditions indiquées dans la Directive 2002/95 CE en référence à la limitation des substances dangereuses indiquées ci-dessous :

Piombo	<i>Lead</i>	Blei	<i>Plomb</i>	[Pb]
Mercurio	<i>Mercury</i>	Quecksilber	<i>Mercur</i>	[Hg]
Cadmio	<i>Cadmium</i>	Cadmium	<i>Cadmium</i>	[Cd]
Cromo esavalente	<i>Hexavalent Chromium</i>	sechswertiges Chrom	<i>Chrome hexavalent</i>	[Cr (VI)]
Bifenile polibromurati	<i>Polybrominated biphenyls</i>	polybromiertes Biphenyl	<i>Diphényle polybromé</i>	[PBB]
Eteri di difenili	<i>Polybrominated</i>	polybromierte	<i>Ether diphénylique</i>	
polibromurati	<i>Diphenyl Ethers</i>	Diphenylether	<i>polybromé</i>	[PBDE]

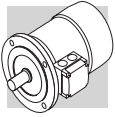
Direzione Ricerca e Sviluppo

Gestione Sistema Qualità



R4.1				
Descrizione	Description	Beschreibung	Description	
 33 34 36	Rimosso motoriduttore AS 80 D_090 dalle tabelle dati tecnici.	<i>Gearmotor AS 80 D_090 removed from technical specification tables.</i>	Getriebemotor AS 80 D_090 aus Tabellen der technischen Daten entfernt.	<i>Enlèvement motoréducteur AS 80 D_090 des tableaux de données techniques</i>
 70 ... 89	Corretto numero fori flangia d'uscita per le forme costruttive F e R.	<i>Corrected number of holes on output flange for the F and R versions.</i>	Korrigiert Anzahl der Löcher am Abtriebsflansch für die F-und R-Bauformen.	<i>Corrigé nombre de trous sur la bride de sortie pour les formes de construction F et R.</i>
 72 73	Corretto dimensione linguetta albero lento per riduttore AS 20.	<i>Output shaft key dimensions corrected for gearbox AS 20.</i>	Maß der Abtriebswellen-Passfeder für Getriebe AS 20 korrigiert.	<i>Correction de la dimension de la languette d'arbre lent pour réducteur AS 20.</i>
 80	Aggiunto dimensioni per riduttore AS 45 D_100 e AS 45 D_112.	<i>Dimensions added for gearboxes AS 45 D_100 and AS 45 D_112.</i>	Maße für Getriebe AS 45 D_100 und AS 45 D_112 hinzugefügt.	<i>Addition des dimensions pour le réducteur AS 45 D_100 et AS 45 D_112.</i>
 89	Corretto dimensione albero veloce per riduttore AS 90 D... HS.	<i>Input shaft dimensions corrected for gearbox AS 90 D... HS.</i>	Maß der Antriebswelle für Getriebe AS 90 D... HS korrigiert.	<i>Correction de la dimension de l'arbre rapide pour réducteur AS 90 D... HS.</i>

Questa pubblicazione annulla e sostituisce ogni precedente edizione o revisione. Ci riserviamo il diritto di apportare modifiche senza preavviso. È vietata la produzione anche parziale senza autorizzazione.

This publication supersedes and replaces any previous edition and revision. We reserve the right to implement modifications without notice. This catalogue cannot be reproduced, even partially, without prior consent.

Diese Veröffentlichung annulliert und ersetzt jeder hergehende Edition oder Revision. BONFIGLIOLI behält sich das Recht vor, Änderungen ohne vorherige Informationen durchzuführen.

Cette publication annule et remplace toutes les autres précédentes. Nous nous réservons le droit d'apporter toutes modifications à nos produits. La reproduction et la publication partielle ou totale de ce catalogue est interdite sans notre autorisation.



Dal 1956 Bonfiglioli progetta e realizza soluzioni innovative ed affidabili per il controllo e la trasmissione di potenza nell'industria e nelle macchine operatrici semoventi e per le energie rinnovabili.

Bonfiglioli has been designing and developing innovative and reliable power transmission and control solutions for industry, mobile machinery and renewable energy applications since 1956.

Seit 1956 plant und realisiert Bonfiglioli innovative und zuverlässige Lösungen für die Leistungsüberwachung und -übertragung in industrieller Umgebung und für selbstfahrende Maschinen sowie Anlagen im Rahmen der erneuerbaren Energien.

Depuis 1956, Bonfiglioli conçoit et réalise des solutions innovantes et fiables pour le contrôle et la transmission de puissance dans l'industrie et dans les machines automotrices et pour les énergies renouvelables.